

TO-220F Plastic-Encapsulate Diodes

MBR2030, 35, 40, 45, 50FCT

SCHOTTKY BARRIER RECTIFIER

FEATURES

- Schottky Barrier Chip
- Guard Ring Die Construction for Transient Protection
- Low Power Loss, High Efficiency
- High Surge Capability
- High Current Capability and Low Forward Voltage Drop
- For Use in Low Voltage, High Frequency Inverters, Free Wheeling, and Polarity Protection Applications

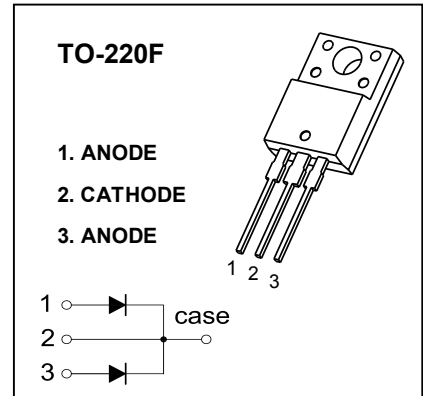

MAXIMUM RATINGS ($T_a=25^\circ\text{C}$ unless otherwise noted)

Symbol	Parameter	Value					Unit
		MBR20 30FCT	MBR20 35FCT	MBR20 40FCT	MBR20 45FCT	MBR20 50FCT	
V_{RRM}	Peak repetitive reverse voltage	30	35	40	45	50	V
V_{RWM}	Working peak reverse voltage						
V_R	DC blocking voltage						
$V_{R(RMS)}$	RMS reverse voltage	21	24.5	28	31.5	35	V
I_O	Average rectified output current	20					A
I_{FSM}	Non-Repetitive peak forward surge current 8.3ms half sine wave	150					A
P_D	Power dissipation	2					W
$R_{\theta JA}$	Thermal resistance from junction to ambient	50					$^\circ\text{C/W}$
T_j	Junction temperature	125					$^\circ\text{C}$
T_{stg}	Storage temperature	-55~+150					$^\circ\text{C}$

ELECTRICAL CHARACTERISTICS (T_a=25°C unless otherwise specified)

Parameter	Symbol	Device	Test conditions	Min	Typ	Max	Unit
Reverse voltage	V _(BR)	MBR2030FCT	I _R =0.1mA	30			V
		MBR2035FCT		35			
		MBR2040FCT		40			
		MBR2045FCT		45			
		MBR2050FCT		50			
Reverse current	I _R	MBR2030FCT	V _R =30V			0.1	mA
		MBR2035FCT	V _R =35V				
		MBR2040FCT	V _R =40V				
		MBR2045FCT	V _R =45V				
		MBR2050FCT	V _R =50V				
Forward voltage	V _F	MBR2030-45FCT	I _F =10A			0.7	V
		MBR2050FCT				0.8	

*Pulse test: pulse width ≤300μs, duty cycle≤ 2.0%.

Typical Characteristics

Forward Characteristics

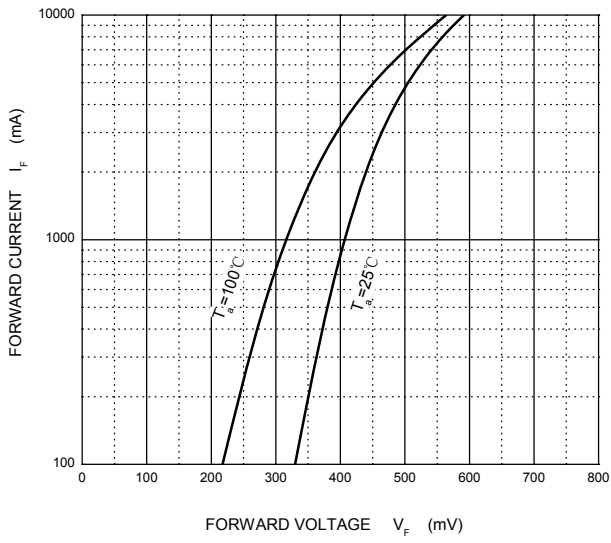

Reverse Characteristics

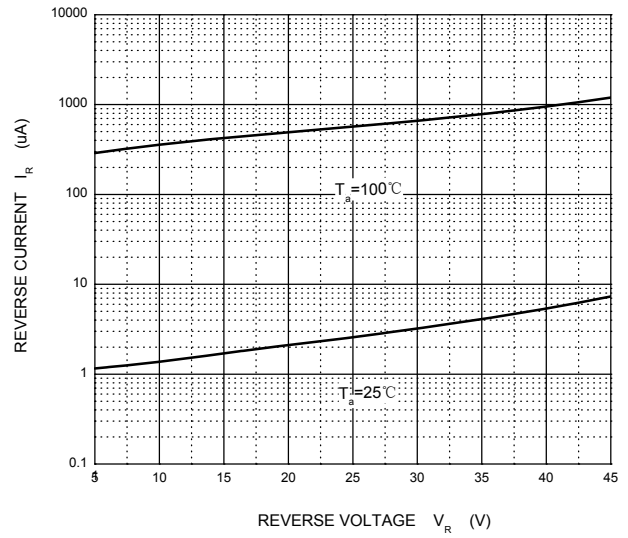

Capacitance Characteristics

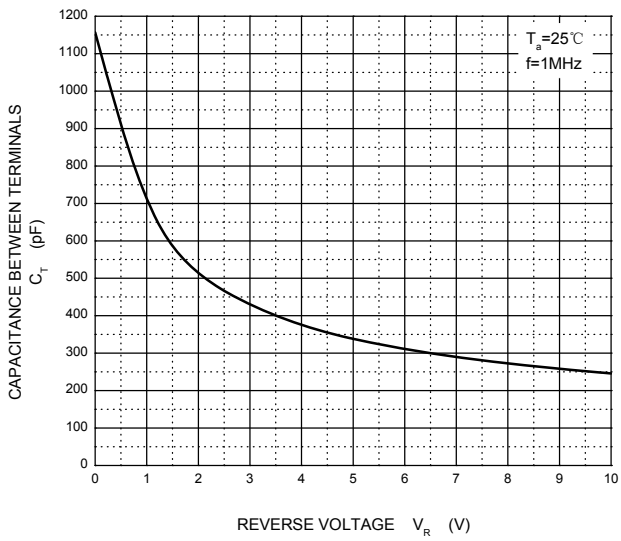

Power Derating Curve

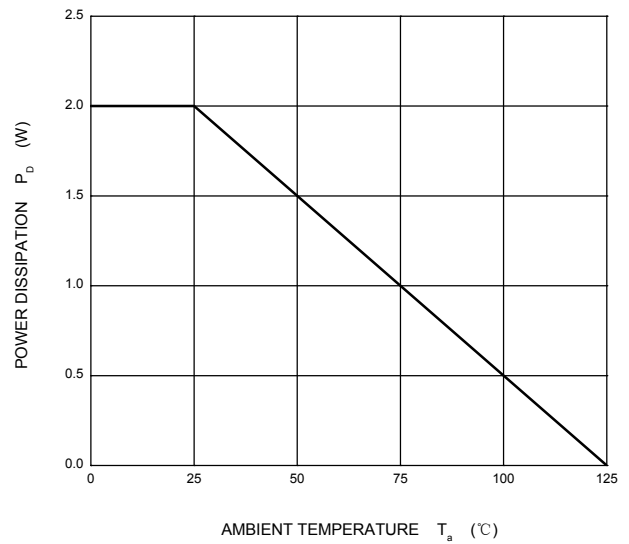

TO-220F Package Outline Dimensions

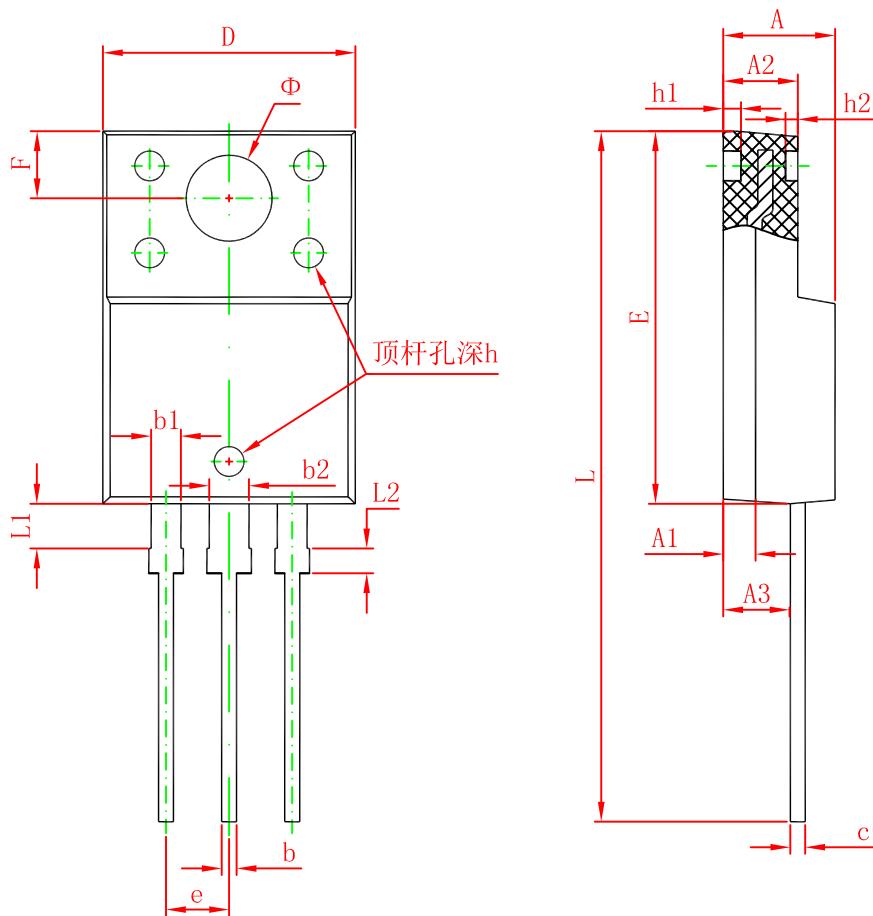

Symbol	Dimensions In Millimeters		Dimensions In Inches	
	Min.	Max.	Min.	Max.
A	4.300	4.700	0.169	0.185
A1	1.300 REF.		0.051 REF.	
A2	2.800	3.200	0.110	0.126
A3	2.500	2.900	0.098	0.114
b	0.500	0.750	0.020	0.030
b1	1.100	1.350	0.043	0.053
b2	1.500	1.750	0.059	0.069
c	0.500	0.750	0.020	0.030
D	9.960	10.360	0.392	0.408
E	14.800	15.200	0.583	0.598
e	2.540 TYP.		0.100 TYP.	
F	2.700 REF.		0.106 REF.	
Φ	3.500 REF.		0.138 REF.	
h	0.000	0.300	0.000	0.012
h1	0.800 REF.		0.031 REF.	
h2	0.500 REF.		0.020 REF.	
L	28.000	28.400	1.102	1.118
L1	1.700	1.900	0.067	0.075
L2	0.900	1.100	0.035	0.043