

FEATURES

- Scales and displays the output of 5A to 2000A, 50mV & 100mV shunts
- Completely self-contained – no additional components required
- Wide power supply inputs: 5 to 40Vdc for 12V/24V/28V applications
- 48V option for telecom supplies
- Isolated-supply models for high-side shunts
- Large, easy-to-read LED display with 0.37" (9.4mm) high digits
- Available in red, blue or green LED displays
- Subminiature 1.38" x 0.88" package with screw-style terminal blocks
- Factory calibrated to $\pm 0.1\%$ accuracy; Reverse-polarity protection
- Over 50 models available
- Digital upgrade for analog meters

Murata Power Solutions' new DCA5-20PC Series dc ammeters are specifically designed to display the output of all popular 50mV and 100mV dc-shunts. 25 input ranges provide for precision measurement of dc currents from 1.000A to 2000A. With the exception of an external shunt, the unit is 100% self-contained – no calibration or user-supplied components are required. Available LED-display colors include brilliant blue, bright green, and standard red. Three power supply options accommodate all popular dc-supply voltages from 5V to 75Vdc, making these ammeters perfect for automotive, industrial, telecom, and marine applications!

DCA5-20PC Series ammeters are housed in 1.38" x 0.88" (35mm x 22mm) rugged packages that feature a large, 0.37"/9.4mm high, LED display. However, display visibility is not compromised in any way: the display can be easily read at distances up to 15 feet (5 meters). All input and power supply connections are made by way of two screw-style terminal blocks. For added flexibility, computer-style jumpers are provided for range-specific decimal point assignments. And, to ensure trouble free installation, all models include reverse-polarity protected power supply inputs.

Two input configurations are offered: grounded shunt ("low-side"), 5-40V-powered, red, green or blue LED models for cost-sensitive applications, and 8-36V isolated-supply models that accept high-side or floating shunts. Isolated-supply models are also available in a choice of red, green, or blue LEDs. Since many dc ammeters are used in battery backup applications, power consumption for 8-36V models is typically 1 Watt, and 75mW for 5-40V models.

Miniature size, wide supply inputs, and no-hassles installation make DCA5-20PC Series ammeters the ideal choice for all your 50 and 100mV shunt ammeter-applications.

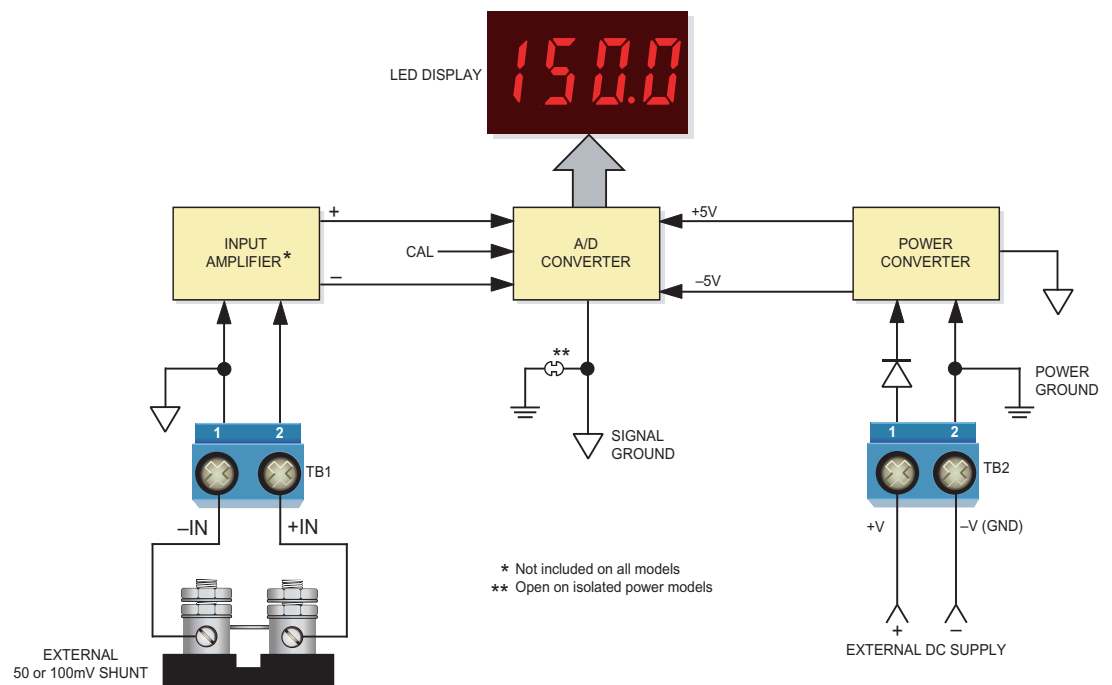

Figure 1. DCA5-20PC Series Simplified Schematic



Performance/Functional Specifications

Typical at T_A = +25°C, unless otherwise noted.

Input (TB1) ①	Min.	Typ.	Max.	Units
Full Scale Input ①	49.5	50	50.5	mV
Overvoltage Rating ②	±400	–	–	mV
Input Impedance	–	1K	–	Ohms
Shunt Input to Power Supply Isolation ③				
DCA5-20PC-X-DC4 models only	500	–	–	Vdc
Performance				
Sampling Rate	2.5 reading per second			
Accuracy	±0.15%FS			
Zero-Current Reading ④	"-001"	"000"	"001"	Counts
Temperature Drift (0 = +60°C)	–	±0.2	±0.4	Cnts/°C
Power Supply Voltage (TB2)				
DCA5-20PC-X-DC1-XX	+5.0	–	+40	Vdc
DCA5-20PC-X-DC4-XX	+8	–	+36	Vdc
Power Supply Current ⑤				
DCA5-20PC-X-DC1-XX (@ 5-40V)	–	10	15	mAdc
DCA5-20PC-X-DC4-XX (@ 8V)	–	100	150	mAdc
DCA5-20PC-X-DC4-XX (@ 36V)	–	25	40	mAdc
TB1 and TB2 Terminal Blocks				
Wire Size	16-22AWG, solid or stranded			
Insulation Strip Length	0.250 inches			
Screw Tightening Torque	2.2 lb-in (0.25 N-m) ±20%			
Rated Current	20A with 12AWG solid copper wire; 15A with 14AWG solid or stranded copper wire			
Display				
Display Type and Size	3½ digit, 0.37" x 9.4mm high red, blue or green LED			
Overrange Indication	"-1 ___" for negative Vin "1 ___" for positive Vin			
Display Reading/Decimal Point	Model dependent			
Physical/Environmental				
Operating Temperature	0	–	+60	°C
Storage Temperature	–20	–	+75	°C
Humidity (non-condensing)	0	–	85	%
Case Material	Polycarbonate			
Dimensions	1.38"W x 0.88" x 1.0" nominal			
Weight	0.6 ounces (17 grams)			

① A full-scale input voltage of 50.00mV is used to calibrate all models for their designated measurement range. The ammeter's rear calibration potentiometer compensates for full-scale input variations up to ±1% (49.5 to 50.5mV).

Measuring positive and negative currents (bipolar operation): In applications where both positive and negative currents must be measured, Murata Power Solutions recommends using '-DC4' 8-36V isolated supply models. Negative current flow is denoted by the illumination of the display's negative (-) sign; the absence of a negative sign implies positive current flow. Contact MPS if you have any questions regarding bipolar operation of DCA5-20PC ammeters.

Ordering Information

DCA5-20PC - X - DC1 - RL - C

Power Supply:
DC1 = +5-40Vdc, non-isolated power (available with -RL, -BL, or -PGL LEDs)
DC4 = +8-36Vdc, isolated power (available with -RL, -BS, or -GS LEDs)

LED Color:
BL = Low-Power Blue
BS = Super Blue
GS = Standard Green
PGL = Low-Power Green
RL = Low-Power Red

Add -C for RoHS

Input Range:

	Use with these 50mV shunts*				or	with these 100mV shunts*			
1	5A	50A	500A			10A	100A	1000A	
2	1A	10A	100A	1000A		2A	20A	200A	2000A
3	30A	300A				60A	600A		
4	75A	750A				15A	150A	1500A	
5	15A	150A	1500A			—			
6	2A	20A	200A	2000A		—			
7	25A	250A				5A	50A	500A	
8	400A					80A	800A		
9	600A					120A	1200A		
10	80A	800A				—			
11	1200A					—			

*With respective decimal point user enabled. See technical note 7.

Please click [here](#) to view the Product Status on Page 7.

Accessories:

Shunt Model	Rating	Use with
DMS-20-CP	Panel Cutout Punch	
3020-01097-0	5A/50mV	DCA5-20PC-1
3020-01107-0	10A/100mV	DCA5-20PC-1
3020-01098-0	20A/50mV	DCA5-20PC-6
3020-01096-0	50A/50mV	DCA5-20PC-1
3020-01099-0	100A/50mV	DCA5-20PC-2
3020-01108-0	100A/100mV	DCA5-20PC-1
3020-01100-0	150A/50mV	DCA5-20PC-5
3020-01101-0	200A/50mV	DCA5-20PC-6
3020-01102-0	300A/50mV	DCA5-20PC-3
3020-01103-0	500A/50mV	DCA5-20PC-1
3020-01104-0	800A/50mV	DCA5-20PC-10
3020-01105-0	1000A/50mV	DCA5-20PC-2
3020-01106-0	1200A/50mV	DCA5-20PC-11

A DMS-BZL4-C bezel assembly with sealing gasket is supplied with each ammeter.

- ② On non-isolated '-DC1' models, continuous application of single-ended ±400mV inputs will not damage the ammeter. Single-ended inputs are defined as those whose TB1-1 (-IN) potential is within ±0.1V of the potential on TB2-2 (-V). For all models, the application of short-duration (5 seconds max.) ±1V inputs will not damage the ammeter.
- ③ Breakdown (isolation) voltage applies only to '-DC4' isolated-power models. Breakdown voltage is tested with TB1-1 tied to TB1-2 (-IN shorted to +IN) and TB2-1 tied to TB2-2 (+V shorted to -V). 500Vdc is then applied between the two shorted terminal-block pairs; the max. allowable leakage current is 5uA.
- ④ Zero reading is measured with TB1-1 (-IN) shorted to TB1-2 (+IN).
- ⑤ Power supply currents noted are measured with the 50mV shunt input (TB1) at zero volts (display reads "000") and one decimal point enabled.
- ⑥ Each model's full-scale display reading with a 50.0mV input is designated by the first X in the DCA5-20PC-X-XXX model number structure. Decimal point selection (DP1, DP2, DP3, or none) is performed by the user to suit desired amperage range. Input ranges -1, -2, -3, -4, -7, -8 and -9 can accommodate 100mV shunts. For these ranges, the indicated 50mV reading is doubled when a 100mV input is applied.

TECHNICAL NOTES

To ensure safe and reliable operation, DCA5-20PC dc ammeters must only be installed and serviced by qualified technical personnel. DC ammeter applications can expose a user to potentially lethal currents and voltages. Power and signal connections must be made with all associated power sources de-energized. Contact Murata Power Solutions if you have any questions regarding the installation or operation of any of our digital instruments.

- 1. Calibration:** DCA5-20PC ammeters are designed to operate with 50mV and 100mV dc shunts whose rated accuracy is $\pm 0.25\%$, or better. The output of less accurate shunts may fall outside the ammeter's $\pm 1\%$ calibration adjustment range. Under normal indoor operating conditions, periodic recalibration of DCA5-20PC ammeters is not necessary. The calibration potentiometer, located on the back of the ammeter, is a $\frac{3}{4}$ turn type; do not force its adjustment screw past the two end stops.

If user calibration is deemed necessary, it must be performed by qualified personnel. Calibration is performed by applying a precision 50.00mVdc or 100mVdc (model specific, see ordering guide) signal to TB1, observing correct polarity. Then, using an insulated slotted tool, adjust the calibration potentiometer until the correct display reading is achieved. Contact MPS if additional information is required regarding calibration or setup of DCA5-20PC ammeters.

- 2. Wiring and Fusing:** Power supply (TB2) and input (TB1) wiring must be rated for the electrical and environmental conditions under which the ammeters will be operated. They must also comply with any regulatory or application-mandated requirements pertaining to the user's installation. Connections to DCA5-20PC ammeters must be made with all power sources de-energized. Refer to the Functional Specifications section for TB1 and TB2 wire gauge information.

DCA5-20PC ammeters' shunt (TB1) and power supply inputs (TB2) are not internally fused. Therefore, the supply wires connected to the meter and the load should be fused according to the maximum current rating (or lower) of the wire gauge used, in accordance with applicable regulatory codes. Insulation should be stripped to within $\pm 10\%$ of the stated dimensions. All wires must be inserted into the terminal block openings such that the screw terminal does not pinch any insulation. TB2 is to be used solely for powering the meter's internal circuitry; it must not be used to supply current to an external load or auxiliary device.

- 3. Terminal Block Torque Ratings:** It is important to tighten TB1's and TB2's screw-terminals to their rated torque specifications of 3.6 pound-inches (0.4Nm). Proper tightening will minimize losses and ensure reliable operation.
- 4. High-Side versus Low-Side Shunts:** Incorrect shunt connections are one of the most common problems encountered when applying digital dc-ammeters. Incorrect shunt connections can cause permanent damage to the ammeter and/or its associated equipment.

Low-Side Shunts: Applications that employ a single power supply to power both the load and the ammeter, and the external shunt is located in the negative side of the supply (commonly referred to as "low side" or "grounded shunt") should use '-DC1' non-isolated power DCA5-20PC Series ammeters. Figures 2, 3, and 4 depict typical low-side shunt connections.

High-Side Shunts: '-DC4' isolated-power ammeters must be used in all applications that employ a single power supply to power both the load and the ammeter and the shunt is located in the high side (positive terminal) of the supply. Figures 5 and 6 depict typical high-side shunt connections. As shown in Figure 6, isolated-power models can also be used in applications

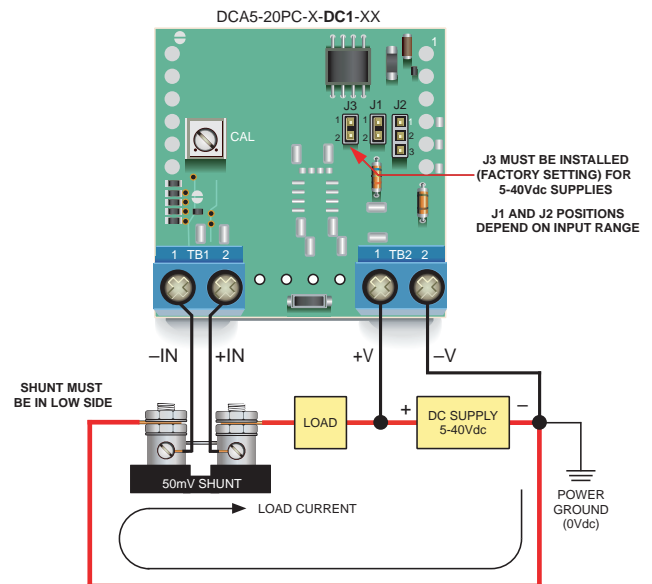

Figure 2. Low-Side Shunt Connections for "-DC1" 5-40Vdc Non-Isolated Supply Models

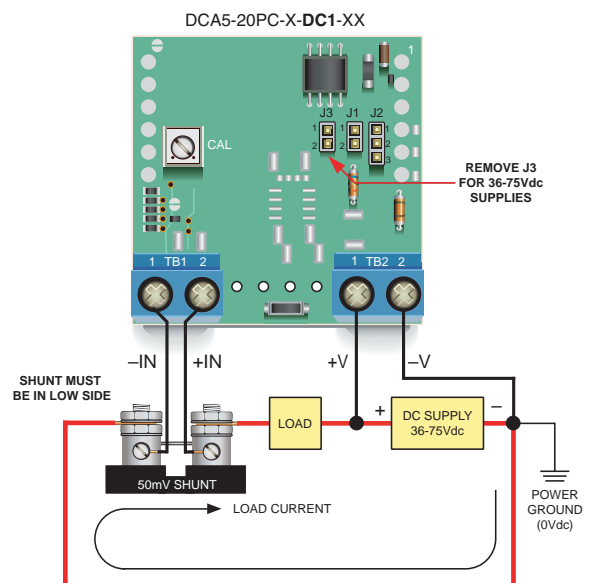

Figure 3. Low-Side Shunt Connections for "-DC1" Models Modified for 36-75Vdc Non-Isolated Power (See Technical Note 5)

where one supply powers the ammeter and a second supply powers the load, but the two supply grounds cannot be tied together. '-DC4' isolated-supply models include a built-in dc/dc converter to provide a minimum of 500Vdc isolation between the shunt (TB1) and power supply inputs (TB2).

- 5. Operation With 36 to 75Vdc Power:** As shipped, all '-DC1' models' rated operating supply range is +5 to +40Vdc. However, '-DC1' models can be user configured for 36 to 75Vdc operation by removing (opening) jumper J3. Please note that this user modification can only be performed on '-DC1' power models. Also, all '-DC1' models – including those that have been modified for 36-75Vdc operation – can only be connected in low-side, grounded-shunt applications. See Figure 3 for detailed wiring information.

APPLICATIONS

Any reconfiguration of J3 must be made prior to connecting the power supply and shunt to the ammeter.

6. Replacing Analog Panel Meters: DCA5-20PC ammeters can be used as replacements for analog panel meters that are driven by 50 or 100mV shunts, if a suitable dc voltage is available for powering the ammeter. In retrofit applications, it is extremely important to determine the shunt's electrical configuration (i.e., high or low side). If any doubt exists as to the shunt's location, use only '-DC4' isolated-supply models. Rewiring must be performed with all power sources de-energized.

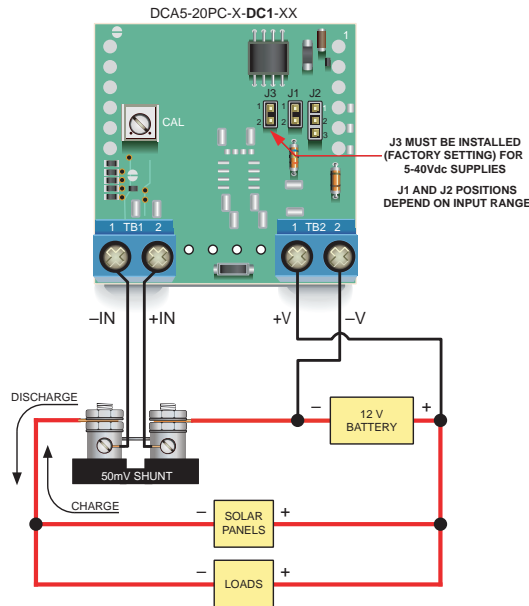

Figure 4. Typical Low-Side Shunt Connections for "-DC1" Models Measuring a Battery's Charge/Discharge Current

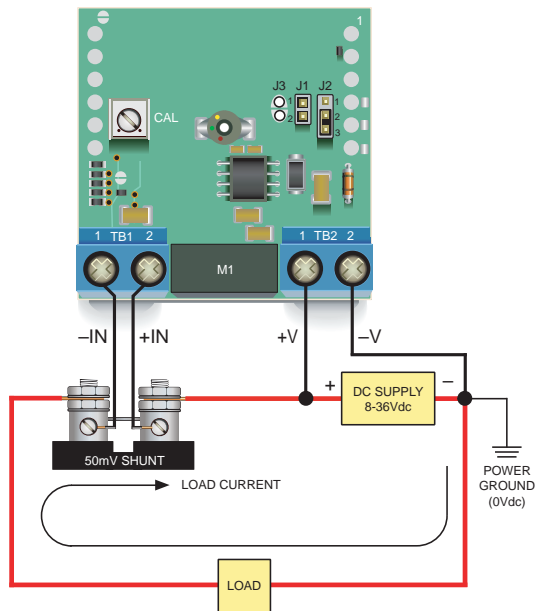

Figure 5. High-Side Shunt Connections for "-DC4" 8-36Vdc Isolated-Power Models

7. Decimal Point Selection: As shown in the Ordering Information guide, DCA5-20PC ammeters are multiple input-range devices. For example, with a 50mV input, DCA5-20PC-1-DC1 models can be configured to display "5.00", "50.0", or "500" Amps by simply removing or relocating decimal-point-selector jumper J2 (see Figure 7). Decimal points serve as placeholders only; they have no effect on displayed accuracy or resolution. If jumper J2 is not available, solder gaps SG1, SG2, or SG3 can be used to select DP1 ("1.XXX"), DP2 ("1X.XX"), or DP3 ("1XX.X"), respectively.

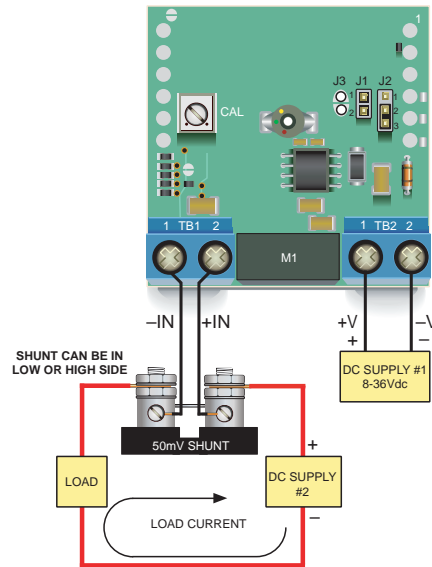

Figure 6. Using "-DC4" Isolated-Power Models to Maintain Isolation Between Two Power Supplies

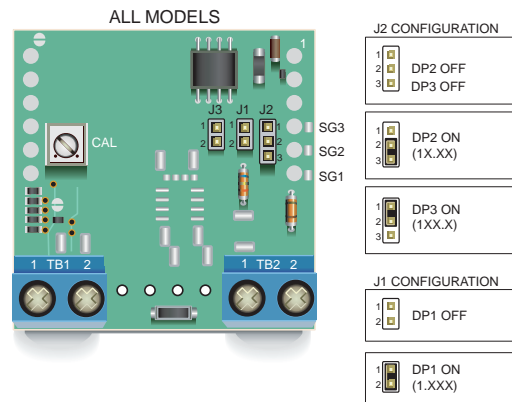

Figure 7. Decimal Point Selection Using J2 and J1 (Applies to All Models)

APPLICATIONS

8. Operation With 100mV Shunts: Many DCA5-20PC Series ammeters can also operate with 100mV shunts. This is due to the fact that when they are driven by a 100mV input, the display readings are double those of a 50mV input. However, a 50mV shunt cannot be used in a 100mV application because its maximum current rating will be exceeded.

For our customer's convenience, Murata Power Solutions offers a series of 50mV and 100mV chassis-mount dc shunts that can be used with DCA5-20PC ammeters. Part numbers for accessory shunts can be found in the Ordering Information section. A data sheet describing these shunts is available at www.murata-ps.com.

Table 1 indicates the obtainable readings of the seven DCA5-20PC models that can be operated with 100mV shunts. Be sure to enable the correct decimal point (see decimal point selection instructions).

9. Noisy Power Supplies: Some power supplies contain high-frequency switching devices that may conduct and/or radiate significant noise onto the low-level 50/100mV shunt signal. Even though the DCA5-20PC incorporates built-in filtering at its shunt input, some portion of this noise may be amplified and subsequently measured by the DCA5-

20PC's sensitive circuitry. The amplified noise introduces errors that are particularly noticeable at zero load current (i.e., the ammeter may not display a relatively steady "000" reading).

Connecting an external, unpolarized capacitor across TB1's "+" and "-" inputs, and/or across the shunt's 50mV output terminals, can help reduce noise-related display errors. In certain situations, the use of twisted pair or shield wiring may be required. As a general rule, avoid using excessively long leads between the ammeter and the shunt.

Table 1. 100mV Shunt Readings *

Model	100mV Shunt Readings
DCA5-20PC-1	10.00A/100.0A/1000A
DCA5-20PC-2	1.999A/19.99A/199.9A/1999A
DCA5-20PC-3	60.0A/600A
DCA5-20PC-4	150.0A/1500A
DCA5-20PC-7	50.0A/500A
DCA5-20PC-8	800A
DCA5-20PC-9	1200A

* With respective decimal point enabled

PANEL INSTALLATION

All connections and modifications must be made after the ammeter is securely attached to the panel, with all load and supply voltages de-energized (off).

The installed wire-positions should be such that minimal forces are applied to TB1, TB2, and the ammeter itself. In high-vibration environments, the use of wiring strain-reliefs is recommended.

To insure a secure panel-mount installation, MPS recommends using the DMS-BZL4-C (with sealing gasket) bezel assembly supplied with each

ammeter. See the Mechanical Specifications section for detailed panel cutout and ammeter dimensions.

Following the four-step sequence shown in Figure 8 below, being careful not to apply excessive force or twisting motions, insert the ammeter into the panel opening. When using the DMS-BZL4-C's sealing gasket, make sure it is positioned between the ammeter's flange and the panel's front surface. Be sure to use and securely tighten all four screws supplied with the bezel assembly.

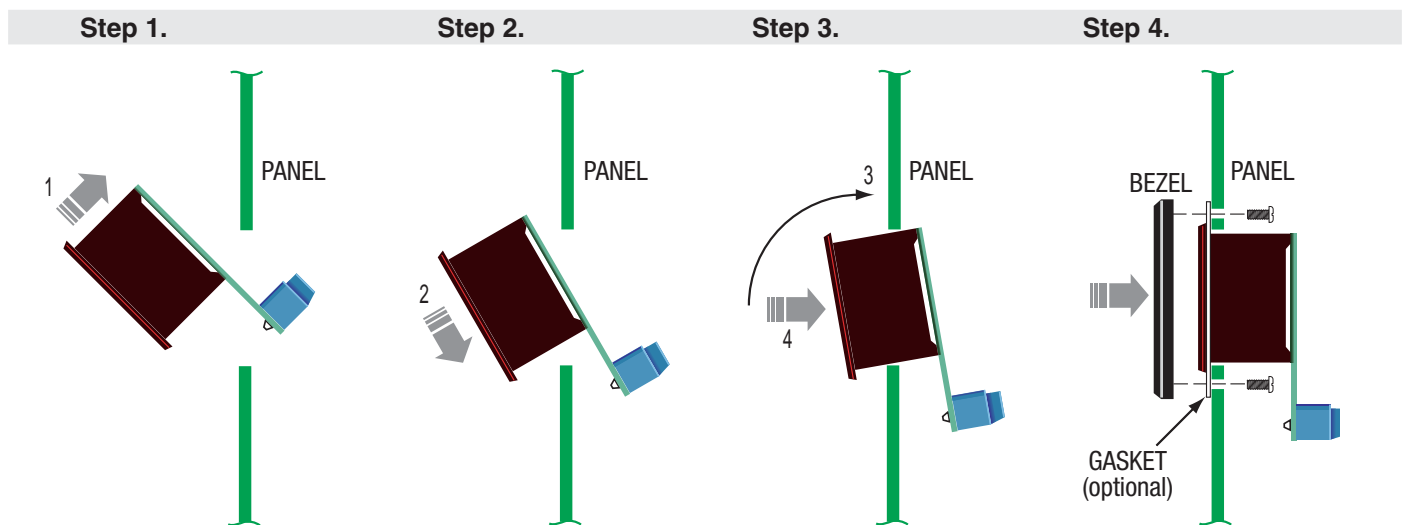
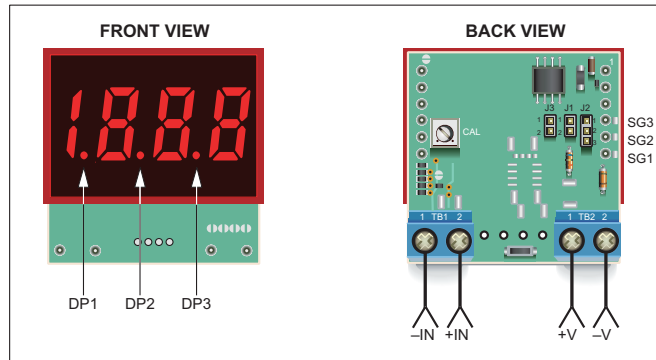
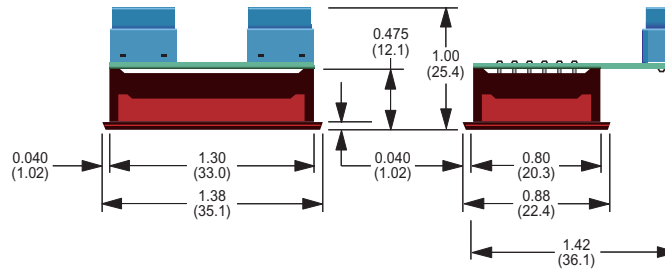

Figure 8. Panel Installation

MECHANICAL SPECIFICATIONS

MECHANICAL DIMENSIONS: Inches (mm)
 TOLERANCES: 2 PL DEC ±0.02 (±0.51)
 3 PL DEC ±0.010 (±0.254)



BEZEL INSTALLATION AND RECOMMENDED DRILL AND PANEL CUTOUT

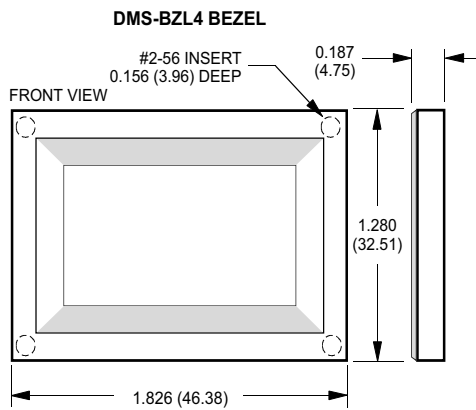

RECOMMENDED DRILL AND PANEL CUTOUT DIMENSIONS

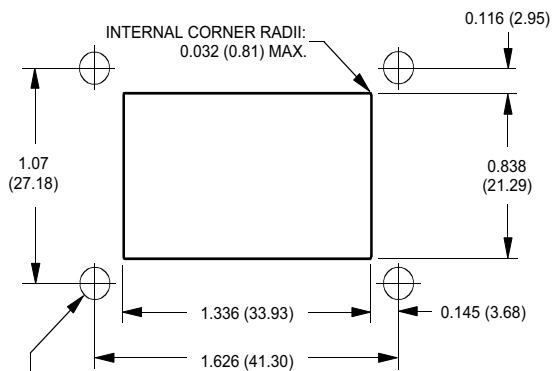

0.093 (2.362) DIAMETER (4 REQUIRED)
 ONLY WHEN USING SUPPLIED BEZEL ASSEMBLY

PRODUCT STATUS:

PART NUMBER	STATUS	LTB DATE
3020-01096-0	To Be Discontinued	9/30/2023
3020-01097-0	To Be Discontinued	9/30/2023
3020-01098-0	To Be Discontinued	9/30/2023
3020-01099-0	To Be Discontinued	9/30/2023
3020-01100-0	To Be Discontinued	9/30/2023
3020-01101-0	To Be Discontinued	9/30/2023
3020-01102-0	To Be Discontinued	9/30/2023
3020-01103-0	To Be Discontinued	9/30/2023
3020-01104-0	To Be Discontinued	9/30/2023
3020-01105-0	To Be Discontinued	9/30/2023
3020-01106-0	To Be Discontinued	9/30/2023
3020-01107-0	To Be Discontinued	9/30/2023
3020-01108-0	To Be Discontinued	9/30/2023
DCA5-20PC-1-DC1-BL-C	Discontinued	9/1/2016
DCA5-20PC-1-DC1-PGL-C	Discontinued	9/1/2016
DCA5-20PC-1-DC1-RL-C	In Production	N/A
DCA5-20PC-1-DC4-BS-C	Discontinued	9/1/2016
DCA5-20PC-1-DC4-GS-C	Discontinued	9/1/2016
DCA5-20PC-1-DC4-RL-C	In Production	N/A
DCA5-20PC-2-DC1-BL-C	Discontinued	9/1/2016
DCA5-20PC-2-DC1-PGL-C	Discontinued	9/1/2016
DCA5-20PC-2-DC1-RL-C	In Production	N/A
DCA5-20PC-2-DC4-BS-C	Discontinued	9/1/2016
DCA5-20PC-2-DC4-GS-C	Discontinued	9/1/2016
DCA5-20PC-2-DC4-RL-C	In Production	N/A
DCA5-20PC-3-DC1-BL-C	Discontinued	9/1/2016
DCA5-20PC-3-DC1-PGL-C	Discontinued	9/1/2016
DCA5-20PC-3-DC1-RL-C	Discontinued	9/1/2016
DCA5-20PC-3-DC4-BS-C	Discontinued	9/1/2016
DCA5-20PC-3-DC4-GS-C	Discontinued	9/1/2016
DCA5-20PC-3-DC4-RL-C	Discontinued	9/1/2016
DCA5-20PC-4-DC1-BL-C	Discontinued	9/1/2016
DCA5-20PC-4-DC1-PGL-C	Discontinued	9/1/2016
DCA5-20PC-4-DC1-RL-C	Discontinued	9/1/2016
DCA5-20PC-4-DC4-BS-C	Discontinued	9/1/2016
DCA5-20PC-4-DC4-GS-C	Discontinued	9/1/2016
DCA5-20PC-4-DC4-RL-C	Discontinued	9/1/2016
DCA5-20PC-5-DC1-BL-C	Discontinued	9/1/2016
DCA5-20PC-5-DC1-PGL-C	Discontinued	9/1/2016
DCA5-20PC-5-DC1-RL-C	Discontinued	9/1/2016

PART NUMBER	STATUS	LTB DATE
DCA5-20PC-5-DC4-BS-C	Discontinued	9/1/2016
DCA5-20PC-5-DC4-GS-C	Discontinued	9/1/2016
DCA5-20PC-5-DC4-RL-C	Discontinued	9/1/2016
DCA5-20PC-6-DC1-BL-C	Discontinued	9/1/2016
DCA5-20PC-6-DC1-PGL-C	Discontinued	9/1/2016
DCA5-20PC-6-DC1-RL-C	Discontinued	9/1/2016
DCA5-20PC-6-DC4-BS-C	Discontinued	9/1/2016
DCA5-20PC-6-DC4-GS-C	Discontinued	9/1/2016
DCA5-20PC-6-DC4-RL-C	Discontinued	9/1/2016
DCA5-20PC-7-DC1-BL-C	In Production	N/A
DCA5-20PC-7-DC1-PGL-C	Discontinued	9/1/2016
DCA5-20PC-7-DC1-RL-C	Discontinued	9/1/2016
DCA5-20PC-7-DC4-BS-C	Discontinued	9/1/2016
DCA5-20PC-7-DC4-GS-C	Discontinued	9/1/2016
DCA5-20PC-7-DC4-RL-C	Discontinued	9/1/2016
DCA5-20PC-8-DC1-BL-C	Discontinued	9/1/2016
DCA5-20PC-8-DC1-PGL-C	Discontinued	9/1/2016
DCA5-20PC-8-DC1-RL-C	Discontinued	9/1/2016
DCA5-20PC-8-DC4-BS-C	Discontinued	9/1/2016
DCA5-20PC-8-DC4-GS-C	Discontinued	9/1/2016
DCA5-20PC-8-DC4-RL-C	Discontinued	9/1/2016
DCA5-20PC-9-DC1-BL-C	Discontinued	9/1/2016
DCA5-20PC-9-DC1-PGL-C	Discontinued	9/1/2016
DCA5-20PC-9-DC1-RL-C	Discontinued	9/1/2016
DCA5-20PC-9-DC4-BS-C	Discontinued	9/1/2016
DCA5-20PC-9-DC4-GS-C	Discontinued	9/1/2016
DCA5-20PC-9-DC4-RL-C	Discontinued	9/1/2016
DCA5-20PC-10-DC1-BL-C	Discontinued	9/1/2016
DCA5-20PC-10-DC1-PGL-C	Discontinued	9/1/2016
DCA5-20PC-10-DC1-RL-C	Discontinued	9/1/2016
DCA5-20PC-10-DC4-BS-C	Discontinued	9/1/2016
DCA5-20PC-10-DC4-GS-C	Discontinued	9/1/2016
DCA5-20PC-10-DC4-RL-C	Discontinued	9/1/2016
DCA5-20PC-11-DC1-BL-C	Discontinued	9/1/2016
DCA5-20PC-11-DC1-PGL-C	Discontinued	9/1/2016
DCA5-20PC-11-DC1-RL-C	Discontinued	9/1/2016
DCA5-20PC-11-DC4-BS-C	Discontinued	9/1/2016
DCA5-20PC-11-DC4-GS-C	Discontinued	9/1/2016
DCA5-20PC-11-DC4-RL-C	Discontinued	9/1/2016
DMS-20-CP	Discontinued	9/1/2016

Please click [here](#) to return to the Ordering Information on Page 2.

Murata Power Solutions, Inc.
 129 Flanders Road, Westborough, MA 01581 U.S.A.
 ISO 9001 and 14001 REGISTERED



This product is subject to the following operating requirements and the Life and Safety Critical Application Sales Policy:
 Refer to: <http://www.murata-ps.com/requirements/>

Murata Power Solutions, Inc. makes no representation that the use of its products in the circuits described herein, or the use of other technical information contained herein, will not infringe upon existing or future patent rights. The descriptions contained herein do not imply the granting of licenses to make, use, or sell equipment constructed in accordance therewith. Specifications are subject to change without notice. © 2023 Murata Power Solutions, Inc.