

DAC7528

CMOS Dual 8-Bit Buffered Multiplying DIGITAL-TO-ANALOG CONVERTER

FEATURES

- DOUBLE BUFFERED DATA LATCHES
- SINGLE 5V SUPPLY OPERATION
- $\pm 1/2$ LSB LINEARITY
- FOUR-QUADRANT MULTIPLICATION
- DACs MATCHED TO 1%

APPLICATIONS

- DIGITALLY CONTROLLED FILTERS
- DISK DRIVES
- AUTO CALIBRATION
- MOTOR CONTROL SYSTEMS
- PROGRAMMABLE GAIN/ATTENUATION
- X-Y GRAPHICS

DESCRIPTION

The DAC7528 contains two, 8-bit multiplying digital-to-analog converters (DACs). Separate on-chip latches hold the input data for each DAC to allow easy interface to microprocessors.

Each DAC operates independently with separate reference input pins and internal feedback resistors. Excellent converter-to-converter matching is maintained.

The DAC7528 operates from a single +5V power supply. The inputs are TTL-compatible. Package options include 20-pin plastic DIP and SOIC.

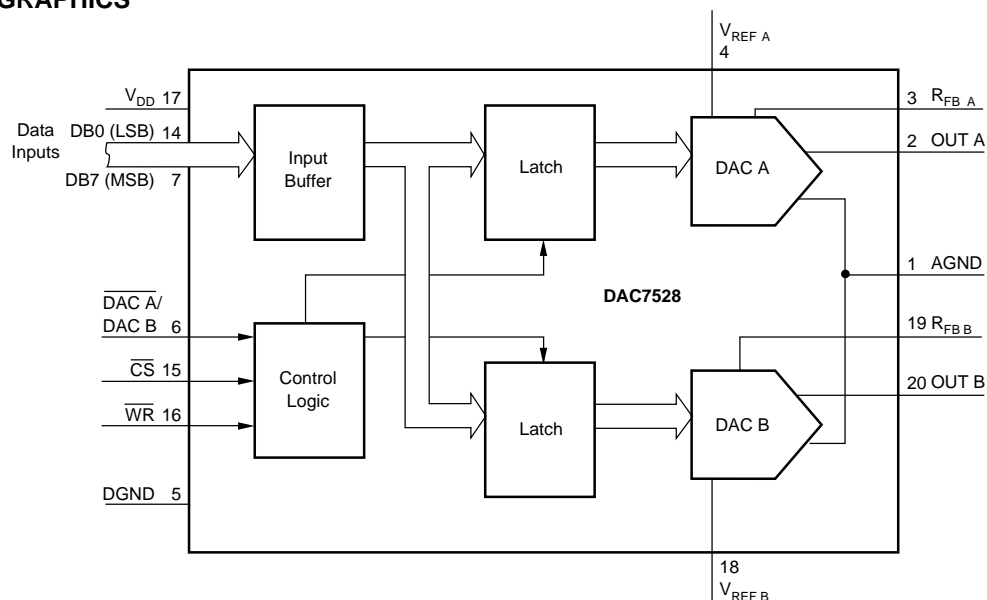

International Airport Industrial Park • Mailing Address: PO Box 11400 • Tucson, AZ 85734 • Street Address: 6730 S. Tucson Blvd. • Tucson, AZ 85706
Tel: (520) 746-1111 • Twx: 910-952-1111 • Cable: BBRCORP • Telex: 066-6491 • FAX: (520) 889-1510 • Immediate Product Info: (800) 548-6132

SPECIFICATIONS

ELECTRICAL

At $V_{DD} = +5V$; $V_{REFA, B} = +10V$; $I_{OUT} = GND = 0V$; $T =$ Full Temperature Range specification under Absolute Maximum Ratings unless otherwise noted.

PARAMETER	SYMBOL	CONDITIONS	DAC7528P, U			DAC7528PB, UB			UNITS
			MIN	TYP	MAX	MIN	TYP	MAX	
DC ACCURACY (1)									
Resolution	N		8			8			Bits
Relative Accuracy	INL				±1			±1/2	LSB
Differential Nonlinearity	DNL	Guaranteed Monolithic Over Temp			±1			±1/2	LSB
FS Gain Error (2)		$T_A = +25^\circ\text{C}$ $T_A = T_{MIN}$ to T_{MAX}			±2			±1	LSB
Gain Tempco (2)(3)				±2	±35			–	ppm/°C
Supply Rejection	PSR	$\Delta V_{DD} = \pm 5\%$, $T_A = +25^\circ\text{C}$ $T_A = T_{MIN}$ to T_{MAX}		0.001	0.01			–	%FSR/%
Output Leakage Current (OUTA)		$DACA = 00_{16}$, $T_A = +25^\circ\text{C}$ $T_A = T_{MIN}$ to T_{MAX}		0.001	0.01			–	%FSR/%
Output Leakage Current (OUTB)		$DACB = 00_{16}$, $T_A = +25^\circ\text{C}$ $T_A = T_{MIN}$ to T_{MAX}			±50			–	nA
					±200			–	nA
					±50			–	nA
					±200			–	nA
REFERENCE INPUT									
Input Resistance		(V_{REFA}, V_{REFB})	8	10	15	–	–	–	kΩ
Input Resistance Match		(V_{REFA}, V_{REFB})			±1			–	%
DYNAMIC PERFORMANCE (4)									
Output Current Settling Time to 1/2 LSB		Enable Pins Low $T_A = +25^\circ\text{C}$ Load = 100Ω/13pF, $T_A = T_{MIN}$ to T_{MAX}			180			–	ns
		Enable Pins Low $T_A = +25^\circ\text{C}$ Load = 100Ω/13pF, $T_A = T_{MIN}$ to T_{MAX}			200			–	ns
Digital-to-Analog Propagation Delay to 90% of Output					80			–	ns
Digital-to-Analog Impulse					100			–	ns
AC Feedthrough (V_{REFA} to OUTA)		$V_{REFA} = 20\text{Vpp}$ Sinewave, $T_A = +25^\circ\text{C}$ 100kHz, $V_{REFB} = 0V$, $T_A = T_{MIN}$ to T_{MAX}		125	–70			–	nVs
AC Feedthrough (V_{REFB} to OUTB)		$V_{REFA} = 20\text{Vpp}$ Sinewave, $T_A = +25^\circ\text{C}$ 100kHz, $V_{REFB} = 0V$, $T_A = T_{MIN}$ to T_{MAX}			–65			–	dB
Channel-to-Channel Isolation (V_{REFA} to OUTB)		$V_{REFA} = 20\text{Vpp}$ Sinewave, 100kHz, $V_{REFB} = 0V$, Both DACs = FF ₁₆		–90	–70			–	dB
Channel-to-Channel Isolation (V_{REFB} to OUTA)		$V_{REFA} = 20\text{Vpp}$ Sinewave 100kHz, $V_{REFB} = 0V$, Both DACs = FF ₁₆		–90	–65			–	dB
Digital Crosstalk		Measured With Code Transition 00 ₁₆ to FF ₁₆		30				–	nVs
Harmonic Distortion	THD	$V_{IN} = 6\text{Vrms}$ at 1kHz		–85				–	dB
ANALOG OUTPUTS (4)									
OUTA capacitance	C_{OUTA}	DAC = 00 ₁₆ DAC = FF ₁₆			50			–	pF
OUTB capacitance	C_{OUTB}	DAC = 00 ₁₆ DAC = FF ₁₆			120			–	pF
					50			–	pF
					120			–	pF
DIGITAL INPUTS									
Input High Voltage	V_{IH}		2.4			–			V
Input Low Voltage	V_{IL}				0.8			–	V
Input Current	I_{IN}	$T_A = +25^\circ\text{C}$ $T_A = T_{MIN}$ to T_{MAX} All Digital Inputs			±1			–	μA
Input Capacitance (4)	C_{IN}				±10			–	μA
					10			–	pF
POWER REQUIREMENTS									
Supply Current	I_{DD}	Digital Inputs = V_{IH} or V_{IL} , $T_A = +25^\circ\text{C}$ $T_A = T_{MIN}$ to T_{MAX} Digital Inputs = 0V or V_{DD} , $T_A = +25^\circ\text{C}$ $T_A = T_{MIN}$ to T_{MAX}			1			–	mA
					1			–	mA
					100			–	μA
					500			–	μA
SWITCHING CHARACTERISTICS (100% tested) See Timing Diagram									
Chip Select To Write Setup Time	t_{CS}	$T_A = +25^\circ\text{C}$ $T_A = T_{MIN}$ to T_{MAX}	200			–			ns
Chip Select To Write Hold Time	t_{CH}	$T_A = +25^\circ\text{C}$ $T_A = T_{MIN}$ to T_{MAX}	230			–			ns
DAC Select To Write Setup Time	t_{AS}	$T_A = +25^\circ\text{C}$ $T_A = T_{MIN}$ to T_{MAX}	20			–			ns
DAC Select To Write Hold Time	t_{AH}	$T_A = +25^\circ\text{C}$ $T_A = T_{MIN}$ to T_{MAX}	30			–			ns
Write Pulse Width	t_{WR}	$T_A = +25^\circ\text{C}$ $T_A = T_{MIN}$ to T_{MAX}	200			–			ns
Data Setup Time	t_{DS}	$T_A = +25^\circ\text{C}$ $T_A = T_{MIN}$ to T_{MAX}	230			–			ns
Data Hold Time	t_{DH}	$T_A = +25^\circ\text{C}$ $T_A = T_{MIN}$ to T_{MAX}	20			–			ns
			30			–			ns
			180			–			ns
			200			–			ns
			110			–			ns
			130			–			ns
			0			–			ns

NOTES: (1) Specifications apply to both DACs. (2) Gain error is measured using internal feedback resistor. Full Scale Range (FSR) = V_{REF} . (3) Guaranteed, but not tested. (4) These characteristics are for design guidance only and are not subject to test.

DICE INFORMATION

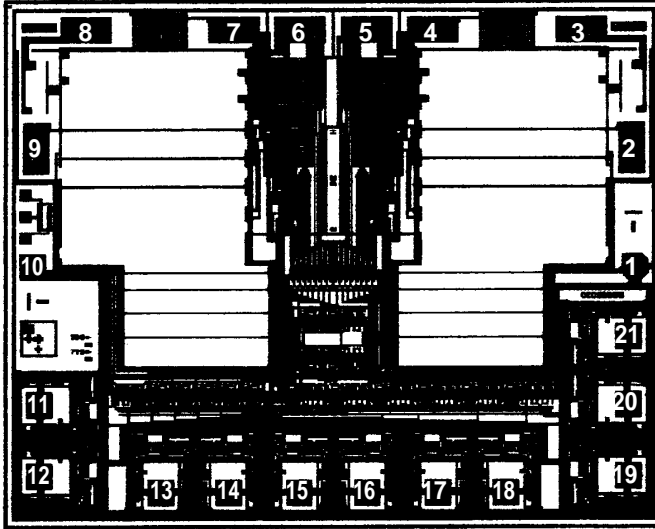

DAC7528 TOPOGRAPHY

PAD	FUNCTION	PAD	FUNCTION	PAD	FUNCTION
1	V _{DD}	8	R _{FB A}	15	DB4
2	V _{REF B}	9	V _{REF B}	16	DB3
3	R _{FB B}	10	DGND	17	DB2
4	OUTB	11	DAC A/DAC B	18	DB1
5	AGNDB	12	DB7	19	DB0
6	AGNDA	13	DB6	20	CS
7	OUTA	14	DB5	21	WR

MECHANICAL INFORMATION

	MILS (0.001")	MILLIMETERS
Die Size	104 x 124	2.6 x 3.1
Die Thickness	20 ±3	0.51 ±0.08
Min. Pad Size	4 x 4	0.10 x 0.10

ELECTRICAL, (DICE)

At V_{DD} = +5V; V_{REF A, B} = +10V; I_{OUT} = GND = 0V; T = Full Temperature Range specification under Absolute Maximum Ratings unless otherwise noted.

PARAMETER	SYMBOL	CONDITIONS	DAC7528AD			UNITS
			MIN	TYP	MAX	
DC ACCURACY ⁽¹⁾						
Resolution	N		8			Bits
Relative Accuracy	INL				±1	LSB
Differential Nonlinearity	DNL	Guaranteed Monolithic Over Temp			±1	LSB
FS Gain Error ⁽²⁾		T _A = +25°C			±2	LSB
		T _A = T _{MIN} to T _{MAX}			±4	LSB
Gain Tempco ^(2, 3)				±2	±35	ppm/°C
Supply Rejection	PSR	ΔV _{DD} = ±5%, T _A = +25°C		0.001	0.01	%FSR/%
		T _A = T _{MIN} to T _{MAX}		0.001	0.01	%FSR/%
Output Leakage Current (OUTA)		DACA = 00 ₁₆ T _A = +25°C			±50	nA
		T _A = T _{MIN} to T _{MAX}			±200	nA
Output Leakage Current (OUTB)		DACB = 00 ₁₆ T _A = +25°C			±50	nA
		T _A = T _{MIN} to T _{MAX}			±200	nA
REFERENCE INPUT						
Input Resistance		(V _{REF A} , V _{REF B})	8	10	15	kΩ
Input Resistance Match		(V _{REF A} , V _{REF B})			±1	%

NOTES: (1) Specifications apply to both DACs. (2) Gain error is measured using internal feedback resistor. Full Scale Range (FSR) = V_{REF}. (3) Guaranteed, but not tested. (4) These characteristics are for design guidance only and are not subject to test.

PACKAGE INFORMATION

MODEL	PACKAGE	PACKAGE DRAWING NUMBER ⁽¹⁾
DAC7528P	20-Pin Plastic DIP	222
DAC7528PB	20-Pin Plastic DIP	222
DAC7528U	20-Pin SOIC	221
DAC7528UB	20-Pin SOIC	221

NOTE: (1) For detailed drawing and dimension table, please see end of data sheet, or Appendix D of Burr-Brown IC Data Book.

ORDERING INFORMATION

MODEL	INL	PACKAGE	TEMPERATURE RANGE
DAC7528P	±1LSB	20-Pin Plastic DIP	-40°C to +85°C
DAC7528PB	±1/2LSB	20-Pin Plastic DIP	-40°C to +85°C
DAC7528U	±1LSB	20-Pin SOIC	-40°C to +85°C
DAC7528UB	±1/2LSB	20-Pin SOIC	-40°C to +85°C

PIN CONFIGURATION

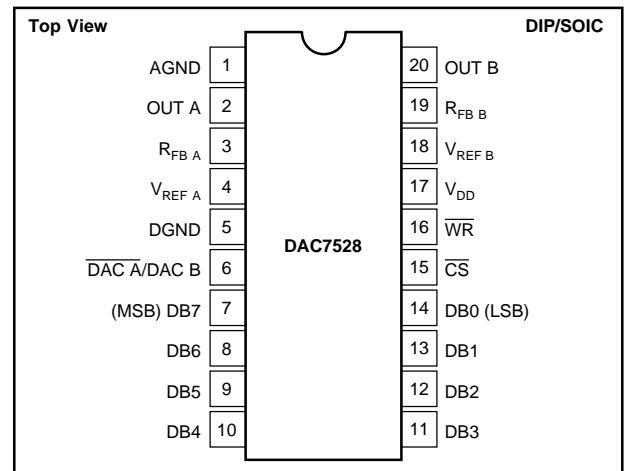

ABSOLUTE MAXIMUM RATINGS

V_{DD} to GND	0V, +7V
$V_{REFA, B}$ to GND	$\pm 25V$
$R_{FA, B}$ to GND	$\pm 25V$
Digital Input Voltage Range	-0.3V to V_{DD}
Output Voltage (pins 2, 20)	-0.3V to V_{DD}
Operating Temperature Range U,P	-40°C to +85°C
DICE	0°C to +70°C
Junction Temperature	+150°C
Storage Temperature	-60°C to +150°C
Lead Temperature (soldering, 10s)	+300°C
θ_{JA} U package	105°C/W
P package	85°C/W
θ_{JC} U package	60°C/W
P package	35°C/W

NOTES: θ_{JA} is specified for worst case mounting conditions, i.e., θ_{JA} is specified for device in socket for PDIP package.

CAUTION: (1) Do not apply voltages higher than V_{DD} or less than GND potential on any terminal except $V_{REFA, B}$ (pins 4 and 18) and $R_{FA, B}$ (pins 3 and 19). (2) The digital control inputs are zener-protected; however, permanent damage may occur on unprotected units from high-energy electrostatic fields. Keep units in conductive foam at all times until ready to use. (3) Use proper antistatic handling procedures. (4) Absolute Maximum Ratings apply to both packaged devices and DICE. Stresses above those listed under Absolute Maximum Ratings may cause permanent damage to the device.



ELECTROSTATIC DISCHARGE SENSITIVITY

Any integrated circuit can be damaged by ESD. Burr-Brown recommends that all integrated circuits be handled with appropriate precautions. Failure to observe proper handling and installation procedures can cause damage.

ESD damage can range from subtle performance degradation to complete device failure. Precision integrated circuits may be more susceptible to damage because very small parametric changes could cause the device not to meet published specifications.

WRITE CYCLE TIMING DIAGRAM

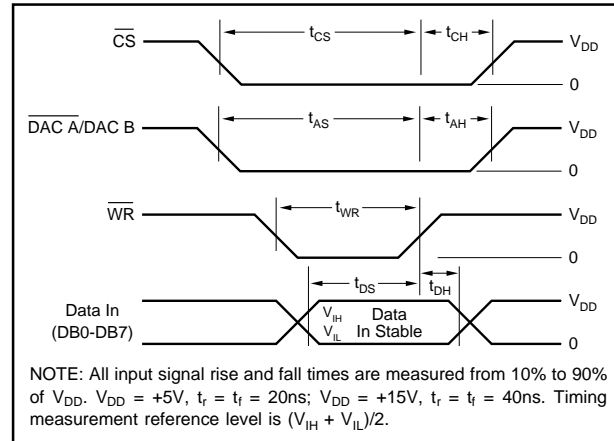

MODE SELECTION TABLE

DAC A/DAC B	\overline{CS}	\overline{WR}	DAC A	DAC B
L	L	L	WRITE	HOLD
H	L	L	HOLD	WRITE
X	H	X	HOLD	HOLD
X	X	H	HOLD	HOLD

Digital Inputs: All digital inputs of the DAC7528 incorporate on-chip ESD protection circuitry. This protection is designed and has been tested to withstand five 2500V positive and negative discharges (100pF in series with 1500 Ω) applied to each digital input.

Analog Pins: Each analog pin has been tested to Burr-Brown's analog ESD test consisting of five 1000V positive and negative discharges (100pF in series with 1500 Ω) applied to each pin. $R_{FB A}$, $V_{REF A}$, $R_{FB B}$, and $V_{REF B}$ show some sensitivity.

TYPICAL PERFORMANCE CURVES

At $V_{DD} = +5V$; $V_{REFA, B} = +10V$; $I_{OUT} = GND = 0V$; T = Full Temperature Range Specification under Absolute Maximum Ratings unless otherwise noted.

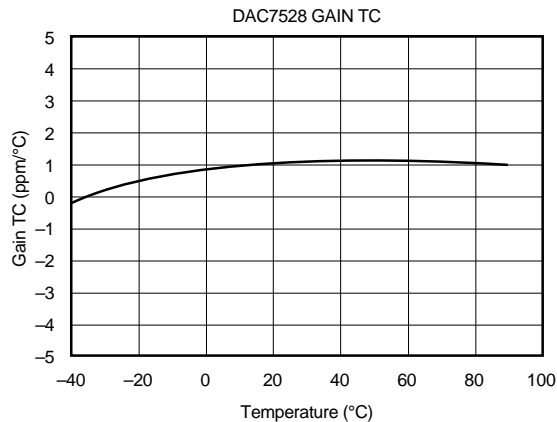
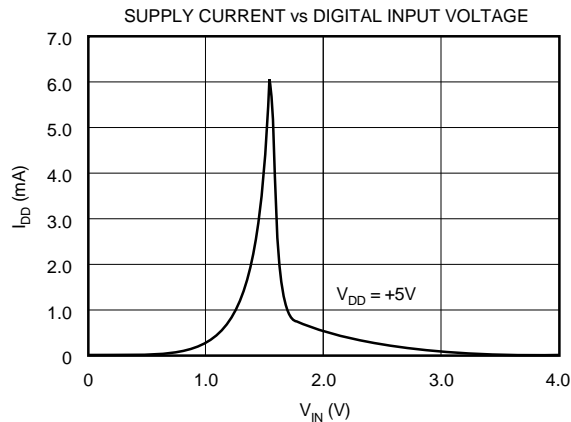

DISCUSSION OF SPECIFICATIONS

RELATIVE ACCURACY

This term, also known as end point linearity or integral linearity, describes the transfer function of analog output to digital input code. Relative accuracy describes the deviation from a straight line, after zero and full scale errors have been adjusted to zero.

DIFFERENTIAL NONLINEARITY

Differential nonlinearity is the deviation from an ideal 1LSB change in the output when the input code changes by 1LSB. A differential nonlinearity specification of 1LSB maximum guarantees monotonicity.

GAIN ERROR

Gain error is the difference between the full-scale DAC output and the ideal value. The ideal full scale output value for the DAC7528 is $-(255/256)V_{REF}$. Gain error may be adjusted to zero using external trims as shown in Figure 4.

OUTPUT LEAKAGE CURRENT

The current which appears at $I_{OUT A}$ and $I_{OUT B}$ with the DAC loaded with all zeros.

OUTPUT CAPACITANCE

The parasitic capacitance measured from $I_{OUT A}$ or $I_{OUT B}$ to AGND.

CHANNEL-TO-CHANNEL ISOLATION

The AC output error due to capacitive coupling from DAC A to DAC B or DAC B to DAC A.

AC FEEDTHROUGH ERROR

The AC output error due to capacitive coupling from V_{REF} to I_{OUT} with the DAC loaded with all zeros.

OUTPUT CURRENT SETTLING TIME

The time required for the output current to settle to within $\pm 0.195\%$ of final value for a full scale step.

DIGITAL-TO-ANALOG IMPULSE

The integrated area of the glitch pulse measured in nanovolt-seconds. The key contributor to digital-to-analog glitch is charge injected by digital logic switching transients.

DIGITAL CROSSTALK

Glitch impulse measured at the output of one DAC but caused by a full scale transition on the other DAC. The integrated area of the glitch pulse is measured in nanovolt-seconds.

CIRCUIT DESCRIPTION

Figure 1 shows a simplified schematic of one half of a DAC7528. The current from the $V_{REF A}$ pin is switched between $I_{OUT A}$ and AGND by 8 single-pole double-throw CMOS switches. This maintains a constant current in each leg of the ladder regardless of the input code. The input resistance at $V_{REF A}$ is therefore constant and can be driven by either a voltage or current, AC or DC, positive or negative polarity, and have a voltage range up to $\pm 20V$.

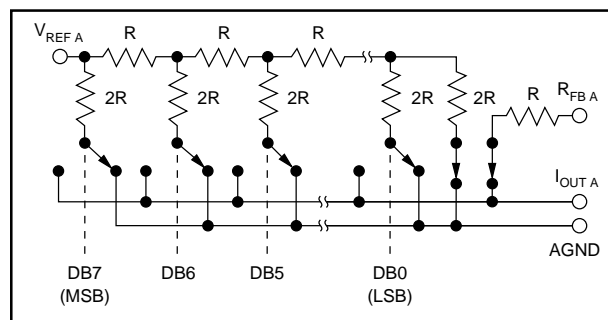

FIGURE 1. Equivalent Circuit for DAC A.

A CMOS switch transistor, included in series with the ladder terminating resistor and in series with the feedback resistor, $R_{FB A}$, compensates for the temperature drift of the ON resistance of the ladder switches.

Figure 2 shows an equivalent circuit for DAC A. C_{OUT} is the output capacitance due to the N-channel switches and varies from about 30pF to 70pF with digital input code. The current source I_{LKG} is the combination of surface and junction leakages to the substrate. I_{LKG} approximately doubles every $10^\circ C$. R_O is the equivalent output resistance of the D/A and it varies with input code.

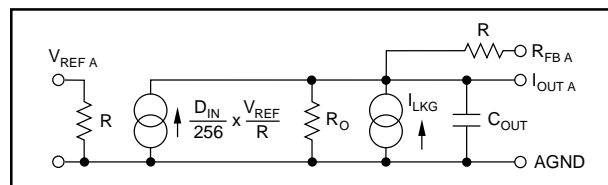

FIGURE 2. Simplified Circuit Diagram for DAC A.

INSTALLATION

ESD PROTECTION

All digital inputs of the DAC7528 incorporate on-chip ESD protection circuitry. This protection is designed to withstand 2.5kV (using the Human Body Model, 100pF and 1500 Ω). However, industry standard ESD protection methods should be used when handling or storing these components. When not in use, devices should be stored in conductive foam or rails. The foam or rails should be discharged to the destination socket potential before devices are removed.

POWER SUPPLY CONNECTIONS

The DAC7528 is designed to operate on $V_{DD} = +5V \pm 10\%$. For optimum performance and noise rejection, power supply decoupling capacitors C_D should be added as shown in the application circuits. These capacitors (1 μ F tantalum recommended) should be located close to the D/A. AGND and DGND should be connected together at one point only, preferably at the power supply ground point. Separate returns minimize current flow in low-level signal paths if properly connected. Output op amp analog common (+ input) should be connected as near to the AGND pin of the DAC7528 as possible.

WIRING PRECAUTIONS

To minimize AC feedthrough when designing a PC board, care should be taken to minimize capacitive coupling between the V_{REF} lines and the I_{OUT} lines. Similarly, capacitive coupling between DACs may compromise the channel-to-channel isolation. Coupling from any of the digital control or data lines might degrade the glitch and digital crosstalk performance. Solder the DAC7528 directly into the PC board without a socket. Sockets add parasitic capacitance (which can degrade AC performance).

AMPLIFIER OFFSET VOLTAGE

The output amplifier used with the DAC7528 should have low input offset voltage to preserve the transfer function linearity. The voltage output of the amplifier has an error component which is the offset voltage of the op amp multiplied by the “noise gain” of the circuit. This “noise gain” is equal to $(R_F/R_O + 1)$ where R_O is the output impedance of the D/A I_{OUT} terminal and R_F is the feedback network impedance. The nonlinearity occurs due to the output impedance varying with code. If the 0 code case is excluded (where $R_O = \text{infinity}$), the R_O will vary from R to $3R$ providing a “noise gain” variation between $4/3$ and 2 . In addition, the variation of R_O is nonlinear with code, and the largest steps in R_O occur at major code transitions where the worst differential nonlinearity is also likely to be experienced. The nonlinearity seen at the amplifier output is $2V_{OS} - 4V_{OS}/3 = 2V_{OS}/3$. Thus, to maintain good nonlinearity the op amp offset should be much less than $1/2\text{LSB}$.

UNIPOLAR CONFIGURATION

Figure 3 shows DAC7528 in a typical unipolar (two-quadrant) multiplying configuration. The analog output values versus digital input code are listed in Table I. The operational amplifiers used in this circuit can be single amplifiers such as the OPA602, or a dual amplifier such as the OPA2107. C_1 and C_2 provide phase compensation to minimize settling time and overshoot when using a high speed operational

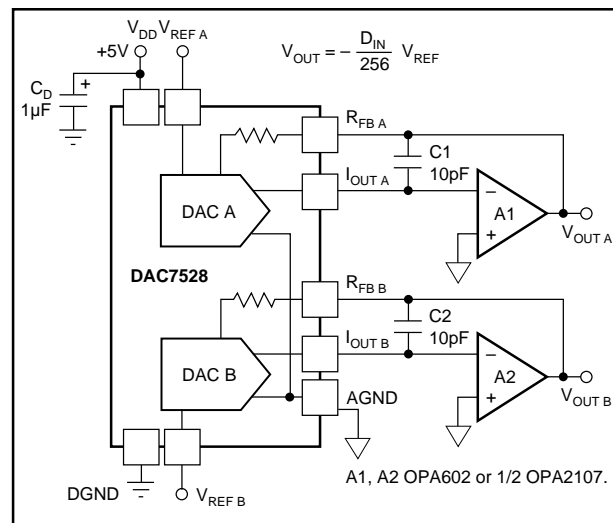

FIGURE 3. Unipolar Configuration 2 Quadrant Multiplication.

amplifier.

If an application requires the D/A to have zero gain error, the circuit shown in Figure 4 may be used. Resistors R_2 and R_4 induce a positive gain error greater than worst-case initial negative gain error. Trim resistors R_1 and R_3 provide a variable negative gain error and have sufficient trim range to correct for the worst-case initial positive gain error plus the error produced by R_2 and R_4 .

BIPOLAR CONFIGURATION

Figure 5 shows the DAC7528 in a typical bipolar (four-quadrant) multiplying configuration. The analog output values versus digital input code are listed in Table II.

The operational amplifiers used in this circuit can be single amplifiers such as the OPA602, a dual amplifier such as the OPA2107, or a quad amplifier like the OPA404. C_1 and C_2 provide phase compensation to minimize settling time and overshoot when using a high speed operational amplifier. The bipolar offset resistors R_1 – R_3 and R_4 – R_6 should be ratio-matched to 0.195% to ensure the specified gain error performance.

APPLICATION INFORMATION

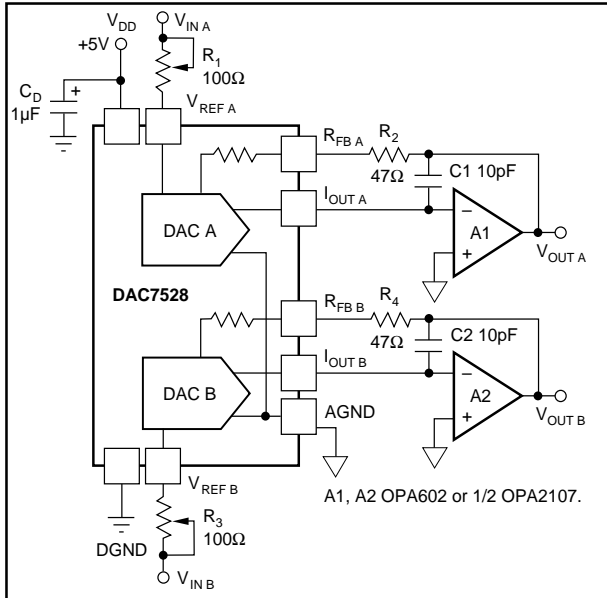

FIGURE 4. Unipolar Configuration with Gain Trim.

DATA INPUT		ANALOG OUTPUT	
MSB ↓	↓ LSB	-V _{REF} (255/256)	
1111	1111	-V _{REF} (255/256) = -1/2V _{REF}	
1000	0000	-V _{REF} (1/256)	
0000	0001	0V	
0000	0000		

TABLE I. Unipolar Output Code.

DATA INPUT		ANALOG OUTPUT	
MSB ↓	↓ LSB	+V _{REF} (127/128)	
1111	1111	+V _{REF} (1/128)	
1000	0001	0V	
1000	0000	-V _{REF} (1/128)	
0111	1111	-V _{REF} (127/128)	
0000	0000		

TABLE II. Bipolar Output Code.

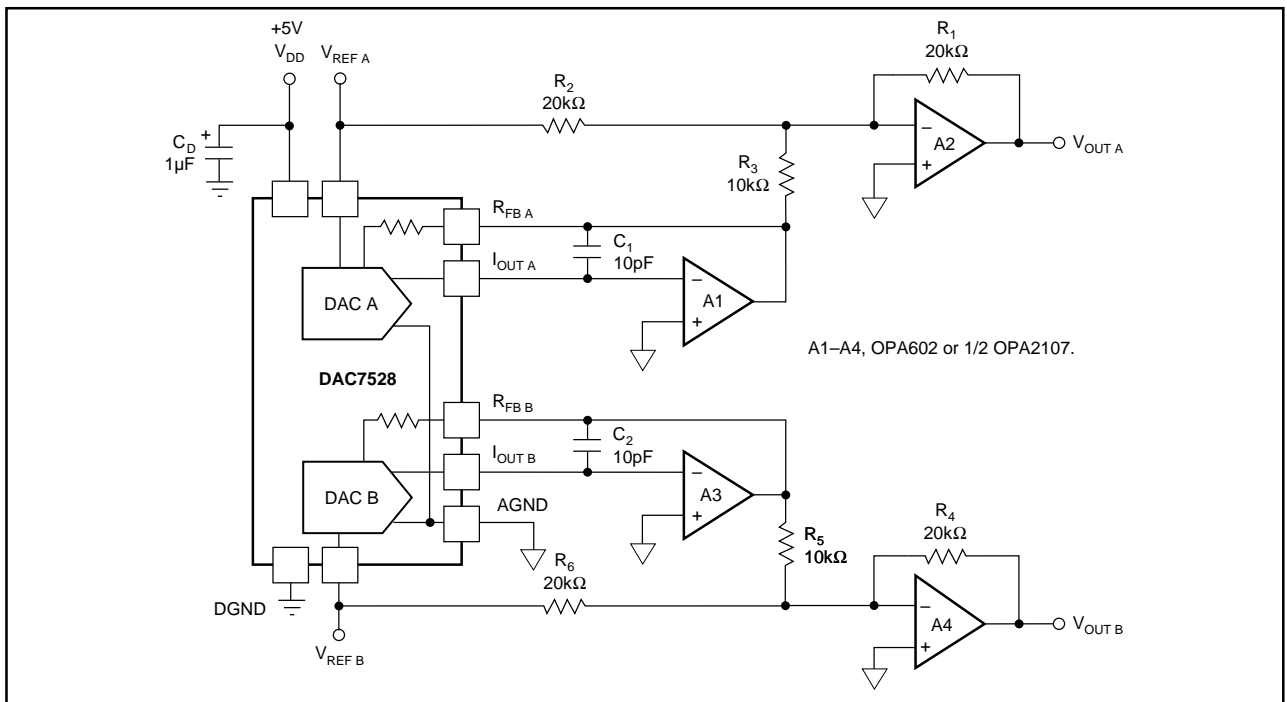
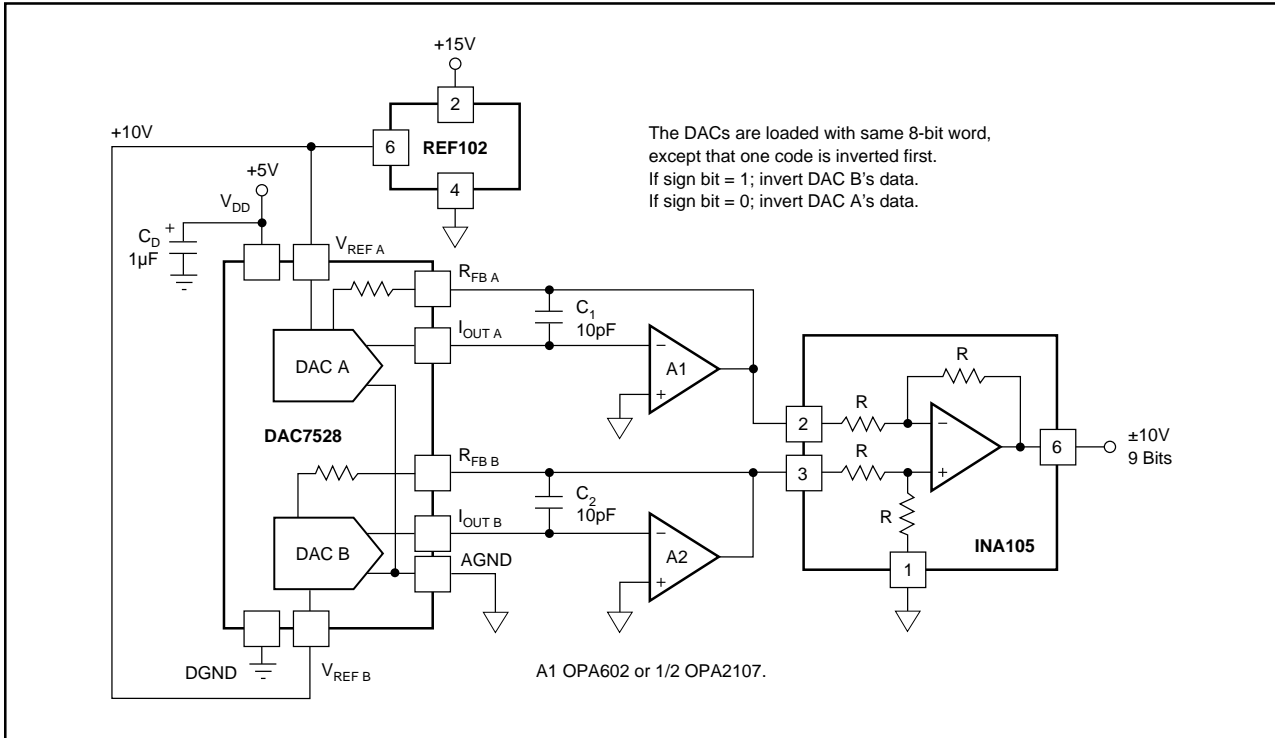

FIGURE 5. Bipolar Configuration 4 Quadrant Multiplication.

APPLICATIONS CIRCUIT: 8-BIT PLUS SIGN DAC



The information provided herein is believed to be reliable; however, BURR-BROWN assumes no responsibility for inaccuracies or omissions. BURR-BROWN assumes no responsibility for the use of this information, and all use of such information shall be entirely at the user's own risk. Prices and specifications are subject to change without notice. No patent rights or licenses to any of the circuits described herein are implied or granted to any third party. BURR-BROWN does not authorize or warrant any BURR-BROWN product for use in life support devices and/or systems.