

Monolithic Broadband Amplifier, 1-6GHz

Features

- Broadband, cascadable gain block
- Flat Frequency response with direct gain control
- High output power capability
- Input and output matched to 50Ω
- No external components required

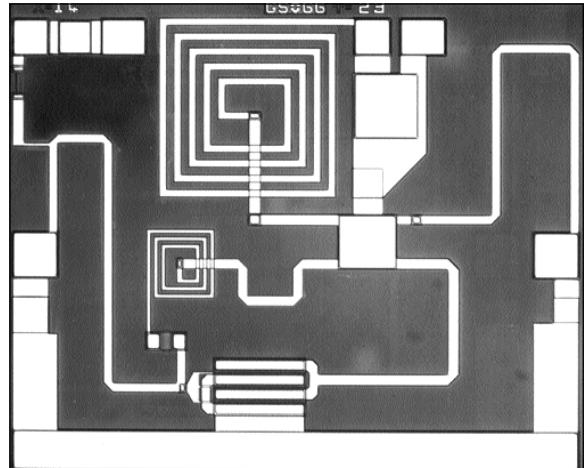

Description

The P35-4110 is a high performance monolithic broadband amplifier designed for use in a wide range of applications including telecommunications, instrumentation and electronic warfare. The amplifier gives typically 7.5dB gain over the frequency range 1GHz to 6GHz. The internal bias networks are designed to minimise the external component count, and are arranged to make the amplifiers easily cascadable for applications requiring more gain.

The die is fabricated using MOC's F14 Gallium Arsenide MESFET MMIC process. It is fully protected using Silicon Nitride passivation for excellent performance and reliability.

Electrical Performance

Ambient temperature = 22±3°C, $Z_O = 50\Omega$, $V_d = 5V$, $I_d = 80mA$

Parameter	Conditions	Min	Typ	Max	Units
Small signal gain ¹	1GHz - 6GHz	6.3	7.5	-	dB
Gain Flatness	1GHz - 6GHz	-	±0.2	±0.3	dB
Input Return Loss ²	1GHz - 6GHz	8.5	9.5	-	dB
Output Return Loss ²	1GHz - 6GHz	7.3	9.5	-	dB
Noise figure	1GHz - 6GHz	-	4.6	4.9	dB
Output Power at 1dB compression		18	20	-	dBm
Reverse Isolation		15	18	-	dB
Gate Voltage V_g	Gate Voltage	0	-1.0	-5.0	Volts
Drain Voltage V_d	Drain Voltage	+4.5	+5.0	+5.5	Volts
Drain Current I_d	$V_g = 0V$	100	150	180	mA

1. The small signal gain and I_d are both reduced by increasing V_g
2. For optimum low frequency performance, it is recommended that the V_d supply is decoupled using an off chip capacitor in the range of 430-1000pF.

Typical Performance at 22°C

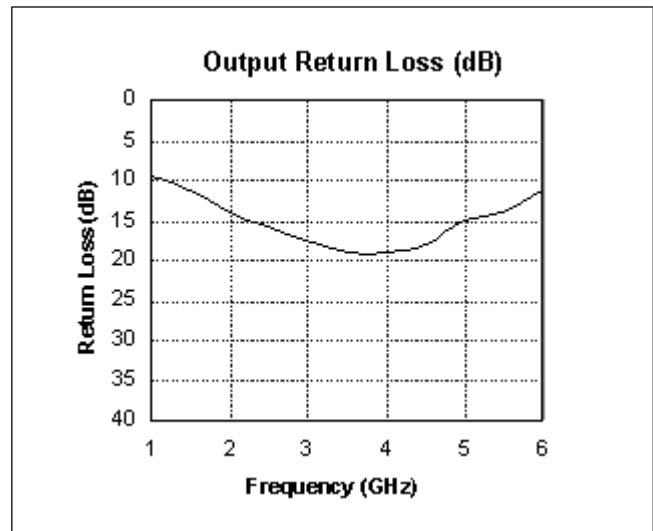
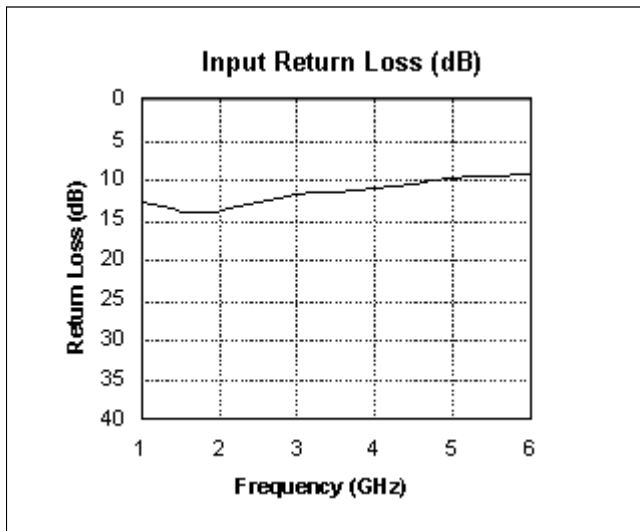
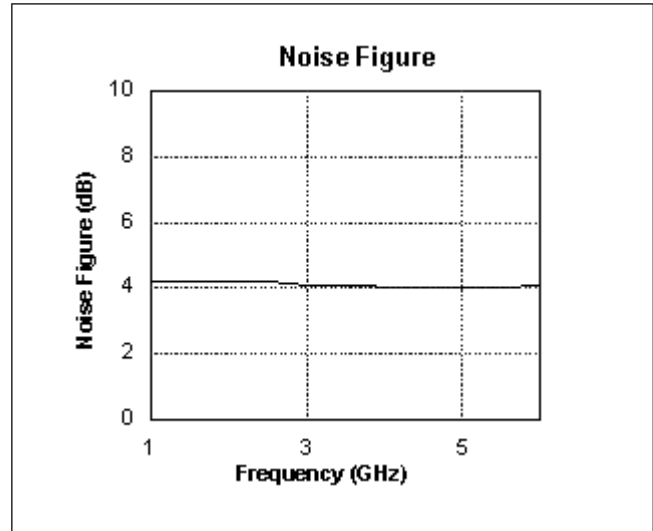
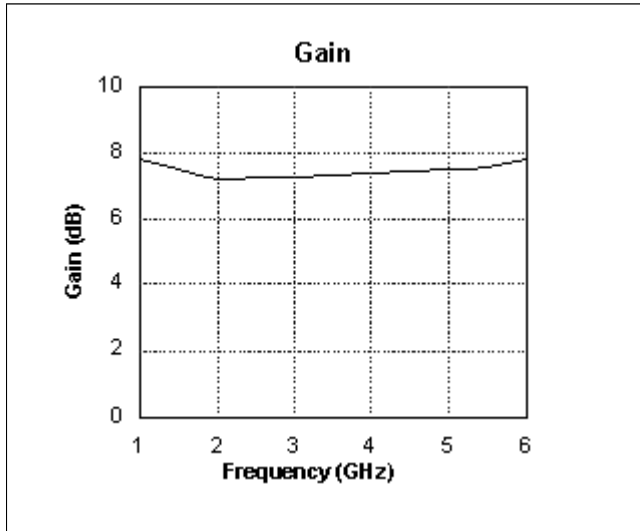

Note:- 2 SMA connectors and bondwires are included in the above data.

Absolute Maximum Ratings

Max Vds	+6.0V
Max Vgs	-5.0V
Die operating temperature	-55°C to 125°C
Storage temperature	-65°C to +150°

Operation

To operate the P35-4110-0 a drain supply of 5V is connected to pad 4. The amplifier circuit is controlled by the voltage applied at pad 2 and should be set to give a drain current of 80mA; the voltage required for this is typically -1V. The small signal gain and Id are both reduced by increasing the magnitude of Vg. Virtually no current is taken by the Vg supply. For optimum low frequency performance, it is recommended that the Vd supply is decoupled using an off chip capacitor in the range of 430-1000pF. It is important that all three ground pads are bonded with minimum inductance to a good DC and RF ground. The gate bias Vg will appear at both input and output bond pads to ease bias connections when cascading die. See application note P35-41-AN5 for more details. The P35-4110 can be made available in packaged form. Contact MOC for details. It is recommended that the chip is mounted with silver loaded epoxy and bonding to all pads is with 25µm diameter pure gold wire using thermal compression bonding.

Die Outline

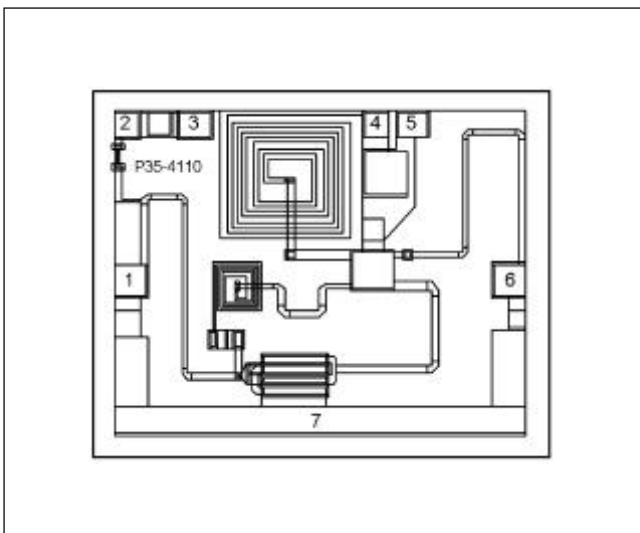

Die size:	1.68 x 2.06mm
Bond pad size:	120µm square
Die thickness	200µm

Die Bias Connections

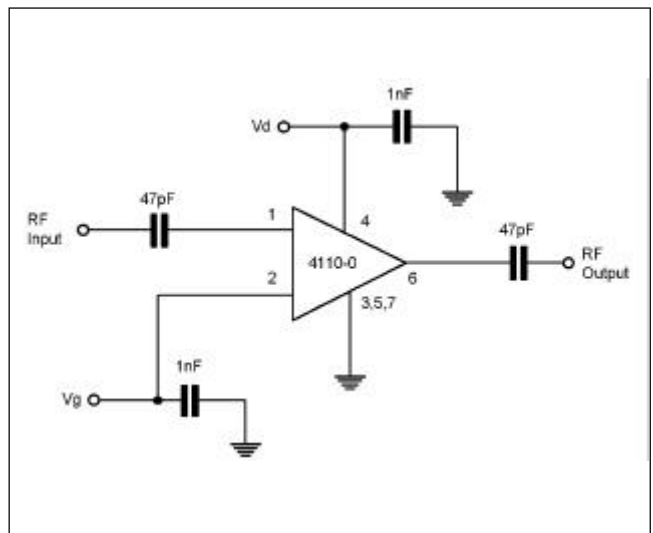

Pad Details

Pin	Function
1	RF IN
2	Gate Voltage Vg
3	GND
4	Drain Voltage Vd
5	GND
6	RF OUT
7	GND

Ordering Information: P35-4110-0 Die

The data and product specifications are subject to change without notice. These devices should not be used for device qualification and production without prior notice.

462/SM/00509/200 Issue 2/1

The logo for Marconi, featuring the word "Marconi" in a stylized, cursive font with a horizontal line underneath.

www.moc.marconi.com

© Marconi Optical Components Ltd 2001

MOC, Caswell, Towcester, Northants, NN12 8EQ, Tel:+44 1327 356468 Fax +44 1327 356698