



Micro Commercial Components  
 20736 Marilla Street Chatsworth  
 CA 91311  
 Phone: (818) 701-4933  
 Fax: (818) 701-4939

# EGP30A THRU EGP30M

## Features

- Superfast recovery time for high efficiency
- Glass passivated cavity-free junction, Plastic case
- Low forward voltage, high current capability
- Low leakage current

## Maximum Ratings

- Operating Temperature: -55°C to +150°C
- Storage Temperature: -55°C to +150°C
- Typical Thermal Resistance: 20°C/W Junction to Ambient

**3.0 Amp Glass  
 Passivated High  
 Efficient Rectifiers  
 50 to 800 Volts**

MCC Part Number	Maximum Recurrent Peak Reverse Voltage	Maximum RMS Voltage	Maximum DC Blocking Voltage
EGP30A	50V	35V	50V
EGP30B	100V	70V	100V
EGP30D	200V	140V	200V
EGP30F	300V	210V	300V
EGP30G	400V	280V	400V
EGP30J	600V	420V	600V
EGP30K	800V	560V	800V
EGP30M	1000V	700V	1000V

## DO-201AE

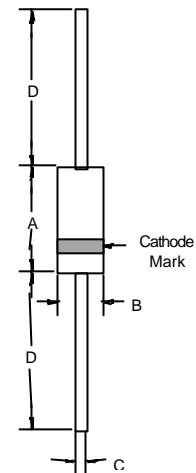

## Electrical Characteristics @ 25°C Unless Otherwise Specified

Maximum Average Forward Current	$I_{F(AV)}$	3.0 A	$T_A = 55^\circ\text{C}$
Peak Forward Surge Current	$I_{FSM}$	125A	8.3ms, half sine
Maximum Instantaneous Forward Voltage EGP30A-30D EGP30F-30G EGP30J-30M	$V_F$	0.95V 1.25V 1.70V	$I_F = 3.0\text{A}$ $T_A = 25^\circ\text{C}$
Maximum DC Reverse Current At Rated DC Blocking Voltage	$I_R$	5.0uA 100uA	$T_A = 25^\circ\text{C}$ $T_A = 125^\circ\text{C}$
Reverse Recovery Time EGP30A-30G EGP30J-30M	$T_{rr}$	50nS 75nS	$T_A = 25^\circ\text{C}$ $I_F = 0.5\text{A}, I_R = 1.0\text{A},$ $I_T = 0.25\text{A}$
Typical Junction Capacitance EGP30A-30D EGP30F-30M	$C_J$	95pF 75pF	Measured at $f = 1.0\text{MHz}$ $V_R = 4.0\text{V}$

DIM	INCHES		MM		NOTE
	MIN	MAX	MIN	MAX	
A	---	.370	---	9.50	
B	---	.250	---	6.40	
C	.038	.042	0.96	1.06	
D	1.000	---	25.40	---	

# EGP30A thru EGP30M

Figure 1  
Typical Forward Characteristics

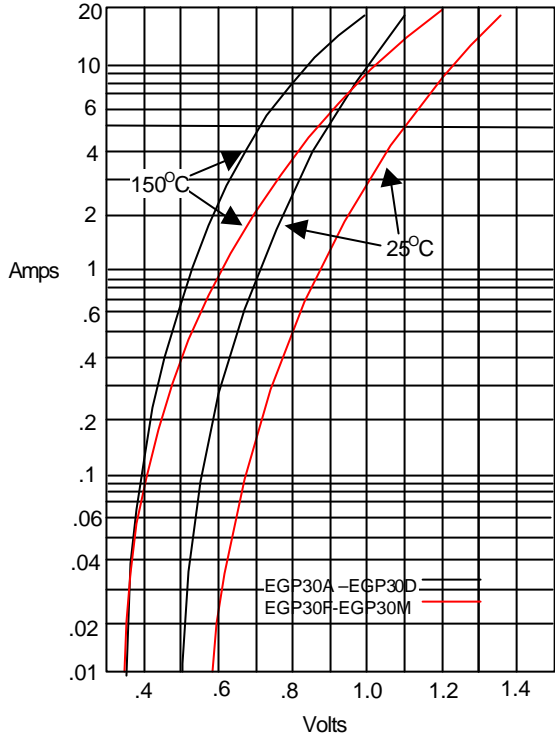

Instantaneous Forward Current - Amperes versus  
Instantaneous Forward Voltage - Volts

Figure 2  
Forward Derating Curve

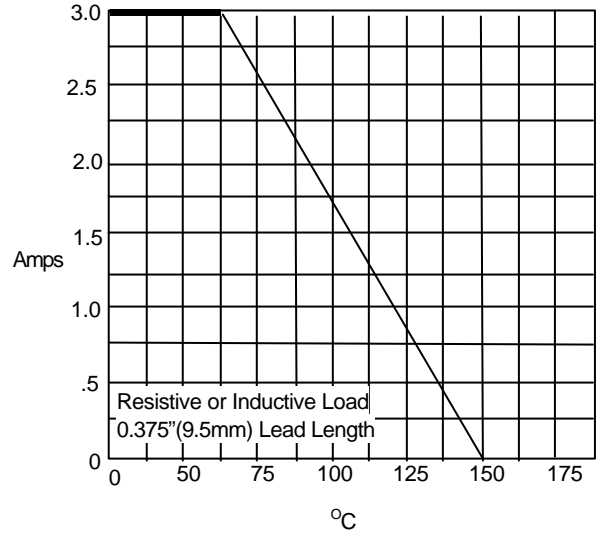

Average Forward Rectified Current - Amperes versus  
Ambient Temperature - °C

Figure 3  
Junction Capacitance

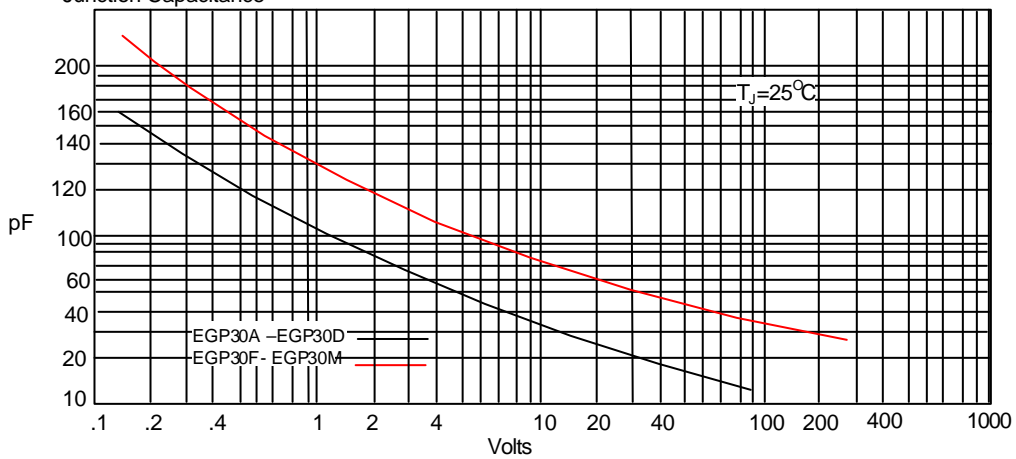

Junction Capacitance - pF versus  
Reverse Voltage - Volts

# EGP30A thru EGP30M

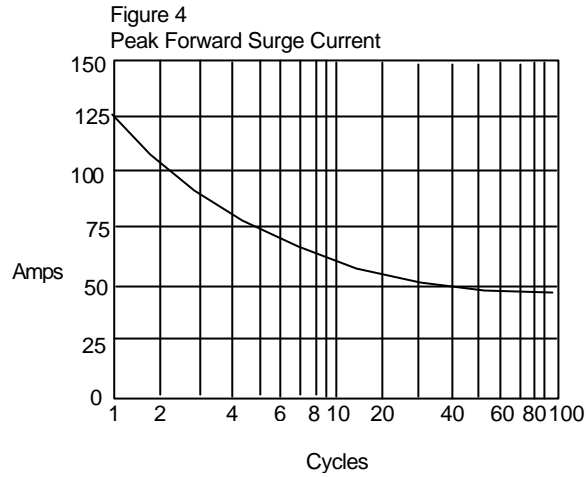

Peak Forward Surge Current - Amperes versus Number Of Cycles At 60Hz - Cycles

Figure 5  
Reverse Recovery Time Characteristic And Test Circuit Diagram

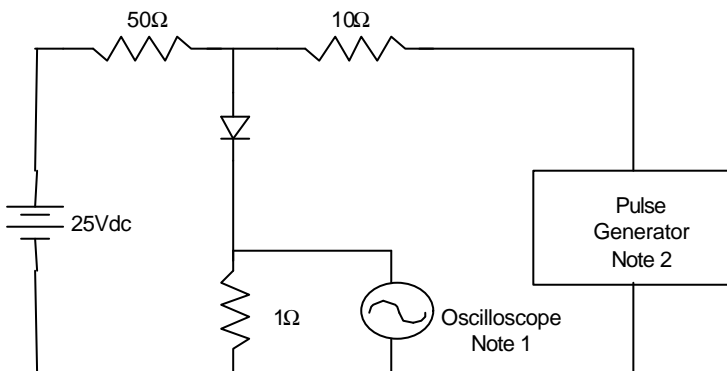

- Notes:
1. Rise Time = 7ns max.  
Input impedance = 1 megohm, 22pF
  2. Rise Time = 10ns max.  
Source impedance = 50 ohms
  3. Resistors are non-inductive

