

# Customer Information Sheet

DRAWING No.: M80-512XXXX

SHEET 2 OF 2

IF IN DOUBT - ASK

©

NOT TO SCALE

THIRD ANGLE PROJECTION

ALL DIMENSIONS IN mm

**SPECIFICATIONS:**

**MATERIAL:**  
 MOULDING = GLASS-FILLED PPS,  
 UL94V-0, BLACK  
 CONTACT = PHOSPHOR BRONZE  
 JACKSCREW = STAINLESS STEEL  
**FINISH (CONTACTS):**  
 05 = 0.75µ GOLD ALL OVER  
 22 = 0.75µ GOLD ON CONTACT AREA,  
 3µ 90/10 TIN/LEAD ON TAILS  
 42 = 0.75µ GOLD ON CONTACT AREA,  
 3µ 100% TIN OVER NICKEL ON TAILS  
**ELECTRICAL:**  
 CURRENT RATING AT 25°C = 3.0A MAX  
 CURRENT RATING AT 85°C = 2.2A MAX  
 WORKING VOLTAGE = 800V AC/DC  
 VOLTAGE PROOF = 1200V AC/DC  
 CONTACT RESISTANCE = 25 mΩ MAX  
 INSULATION RESISTANCE = 100 MΩ MIN  
**MECHANICAL:**  
 DURABILITY = 500 OPERATIONS  
**ENVIRONMENTAL:**  
 TEMPERATURE RANGE = -55°C TO +125°C  
**PACKING:**  
 TUBE WITH FIXINGS IN ATTACHED BAG.  
 FOR COMPLETE SPECIFICATION, SEE  
 COMPONENT SPEC. C005XX (LATEST ISSUE)

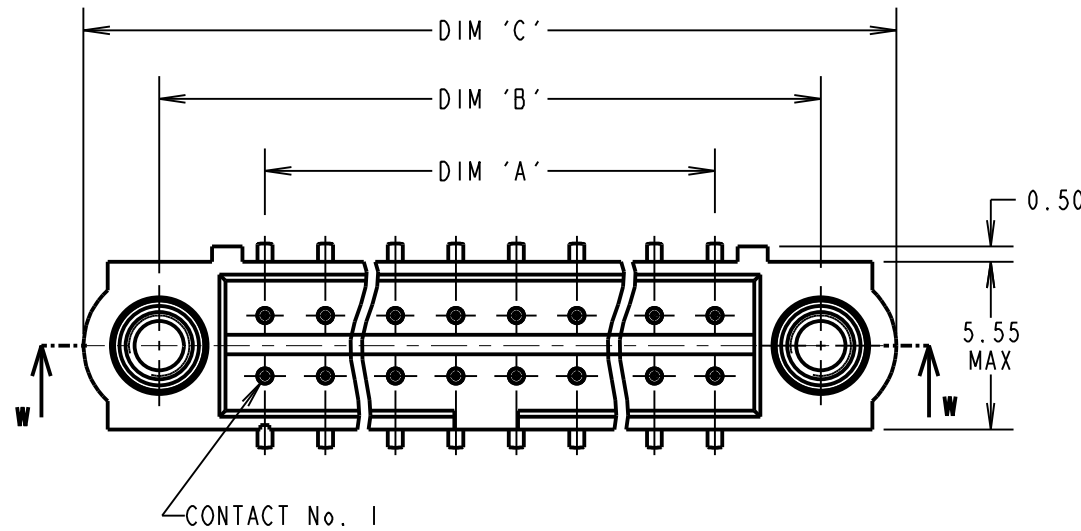

**RECOMMENDED PCB LAYOUT**

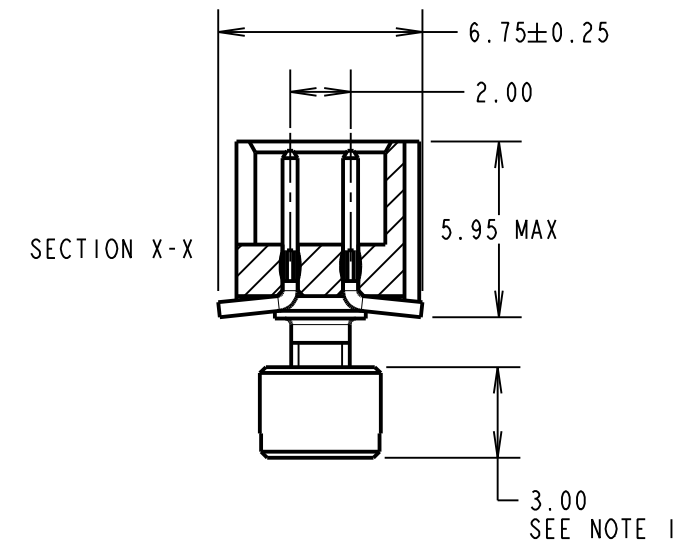
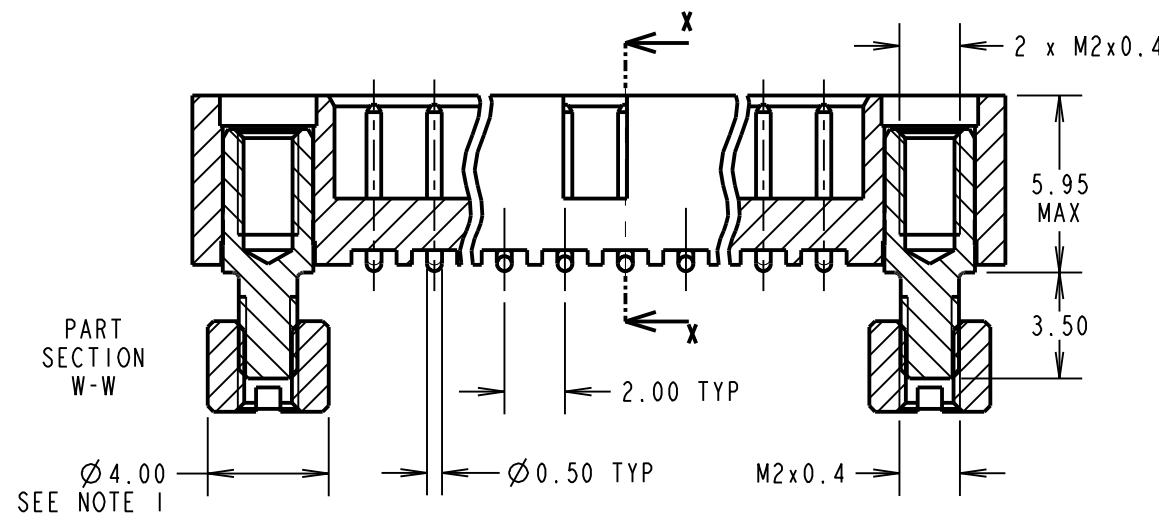
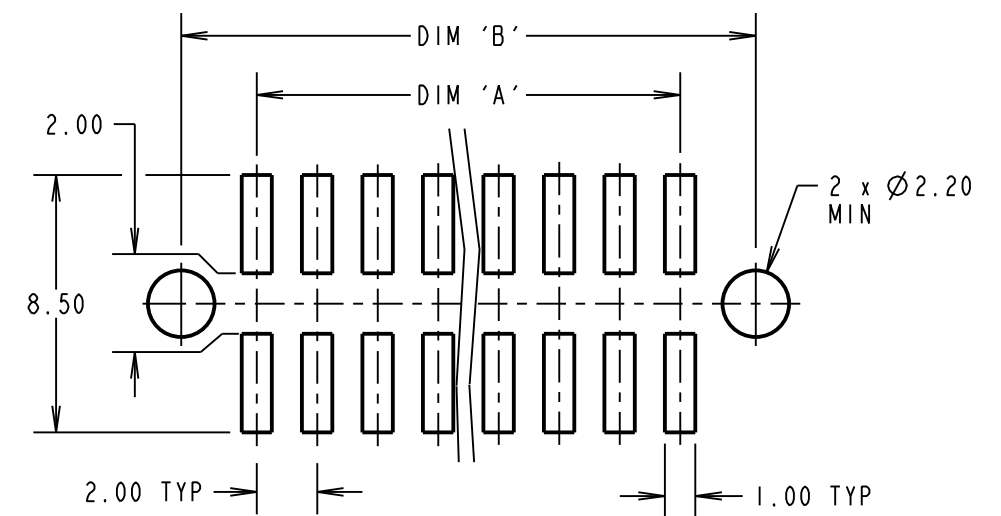

DIMENSION	CALCULATION
DIM 'A'	TOTAL No. OF CONTACTS - 2
DIM 'B'	TOTAL No. OF CONTACTS + 5
DIM 'C'	TOTAL No. OF CONTACTS + 10

EXAMPLE: CONNECTOR WITH 20 CONTACTS, GOLD ON CONTACT AREA AND 100% TIN ON TAIL, M80-5122042.  
 DIM 'A' = 18.00mm, DIM 'B' = 25.00mm, DIM 'C' = 30.00mm

**NOTES:**  
 1. CONNECTOR IS SUPPLIED WITH BOARD MOUNT NUTS NOT ASSEMBLED AS SHOWN. SUPPLIED LOOSE IN BAG ATTACHED TO PACKING TUBE.

ORDER CODE:

**M80-512XXXX**

TOTAL No. OF CONTACTS  
 04 TO 50  
 (EVEN NUMBERS ONLY)

**FINISH**  
 05 - GOLD ALL OVER  
 22 - GOLD ON CONTACT AREA / TIN/LEAD ON TAIL  
 42 - GOLD ON CONTACT AREA / 100% TIN ON TAIL

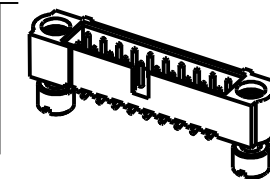

MSP	8	04.04.16	13302
NAME	ISS.	DATE	C/NOTE
APPROVED:			
CHECKED:			
DRAWN:		W. J. BOURNE	
CUSTOMER REF.:			
ASSEMBLY DRG:			

**HARWIN**

www.harwin.com  
 technical@harwin.com

THIS DRAWING AND ANY INFORMATION OR DESCRIPTIVE MATTER SET OUT HEREON ARE CONFIDENTIAL AND COPYRIGHT PROPERTY OF THE HARWIN GROUP AND MUST NOT BE DISCLOSED, LOANED, COPIED OR USED FOR MANUFACTURING, TENDERING OR FOR ANY OTHER PURPOSE WITHOUT THEIR WRITTEN PERMISSION.

**TOLERANCES**  
 X. = ±1mm  
 X.X = ±0.50mm  
 X.XX = ±0.10mm  
 X.XXX = ±0.01mm  
 ANGLES = ±5°  
 UNLESS STATED

**MATERIAL:**  
 SEE ABOVE  
**FINISH:**  
 SEE ABOVE  
**S/AREA:**  
 mm<sup>2</sup>

**TITLE:**  
 DATAMATE J-TEK  
 MALE VERTICAL SMT ASSY  
 WITH 3.5mm BOARD MOUNT

**DRAWING NUMBER:**  
**M80-512XXXX**  
 SHT 2 OF 2