

SN54AHCT258, SN74AHCT258 QUADRUPLE 2-LINE TO 1-LINE DATA SELECTORS/MULTIPLEXERS WITH 3-STATE OUTPUTS

SCLS344E – MAY 1996 – REVISED OCTOBER 1998

- **Inputs Are TTL-Voltage Compatible**
- **EPIC™ (Enhanced-Performance Implanted CMOS) Process**
- **Package Options Include Plastic Small-Outline (D), Shrink Small-Outline (DB), Thin Very Small-Outline (DGV), Thin Shrink Small-Outline (PW), and Ceramic Flat (W) Packages, Ceramic Chip Carriers (FK), and Standard Plastic (N) and Ceramic (J) DIPs**

SN54AHCT258 . . . J OR W PACKAGE
SN74AHCT258 . . . D, DB, DGV, N, OR PW PACKAGE
(TOP VIEW)

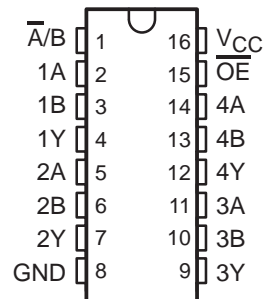

SN54AHCT258 . . . FK PACKAGE
(TOP VIEW)

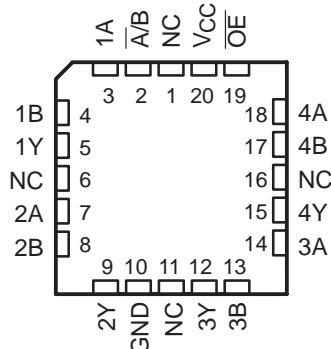

NC – No internal connection

description

These quadruple 2-line to 1-line data selectors/multiplexers are designed for 4.5-V to 5.5-V V_{CC} operation.

The 'AHCT258 devices are designed to multiplex signals from 4-bit data sources to 4-output data lines in bus-organized systems. The 3-state outputs do not load the data lines when the output-enable (\overline{OE}) input is at the high logic level.

To ensure the high-impedance state during power up or power down, \overline{OE} should be tied to V_{CC} through a pullup resistor; the minimum value of the resistor is determined by the current-sinking capability of the driver.

The SN54AHCT258 is characterized for operation over the full military temperature range of -55°C to 125°C . The SN74AHCT258 is characterized for operation from -40°C to 85°C .

FUNCTION TABLE

INPUTS				OUTPUT Y
\overline{OE}	$\overline{A/B}$	A	B	
H	X	X	X	Z
L	L	L	X	H
L	L	H	X	L
L	H	X	L	H
L	H	X	H	L



Please be aware that an important notice concerning availability, standard warranty, and use in critical applications of Texas Instruments semiconductor products and disclaimers thereto appears at the end of this data sheet.

EPIC is a trademark of Texas Instruments Incorporated.

PRODUCT PREVIEW information concerns products in the formative or design phase of development. Characteristic data and other specifications are design goals. Texas Instruments reserves the right to change or discontinue these products without notice.

**TEXAS
INSTRUMENTS**

POST OFFICE BOX 655303 • DALLAS, TEXAS 75265

Copyright © 1998, Texas Instruments Incorporated

PRODUCT PREVIEW

SN54AHCT258, SN74AHCT258 QUADRUPLE 2-LINE TO 1-LINE DATA SELECTORS/MULTIPLEXERS WITH 3-STATE OUTPUTS

SCLS344E – MAY 1996 – REVISED OCTOBER 1998

logic symbol†

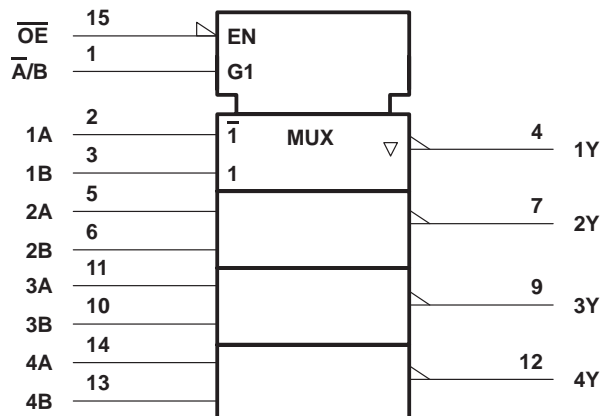

† This symbol is in accordance with ANSI/IEEE Std 91-1984 and IEC Publication 617-12. Pin numbers shown are for the D, DB, DGV, J, N, PW, and W packages.

logic diagram (positive logic)

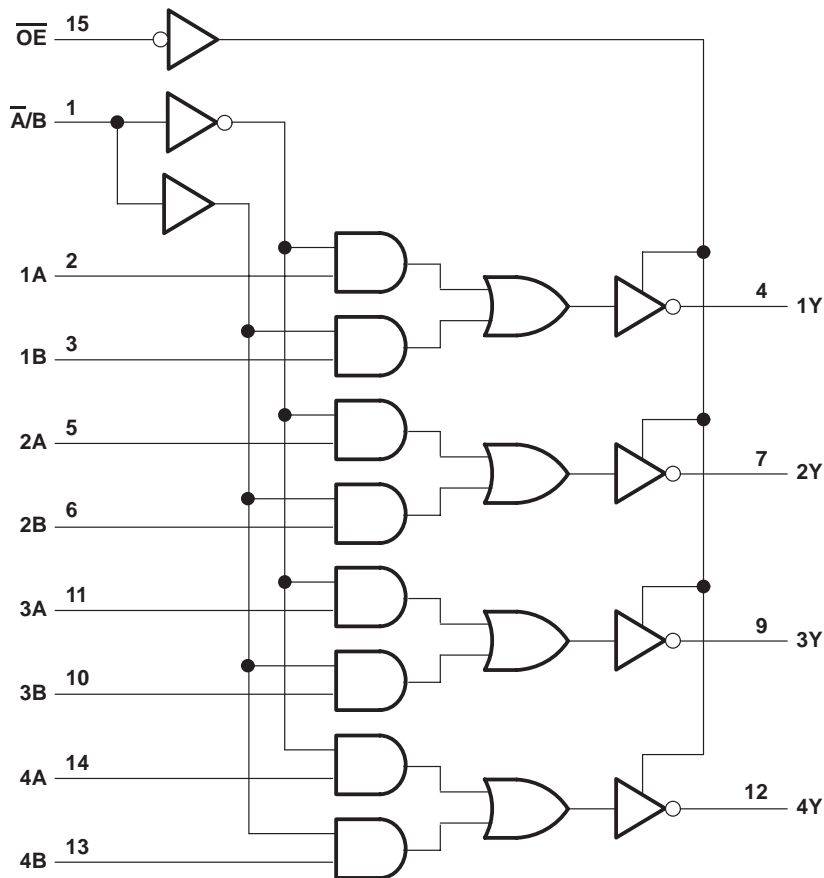

Pin numbers shown are for the D, DB, DGV, J, N, PW, and W packages.

PRODUCT PREVIEW



POST OFFICE BOX 655303 • DALLAS, TEXAS 75265

SN54AHCT258, SN74AHCT258 QUADRUPLE 2-LINE TO 1-LINE DATA SELECTORS/MULTIPLEXERS WITH 3-STATE OUTPUTS

SCLS344E – MAY 1996 – REVISED OCTOBER 1998

absolute maximum ratings over operating free-air temperature range (unless otherwise noted)†

Supply voltage range, V_{CC}	–0.5 V to 7 V
Input voltage range, V_I (see Note 1)	–0.5 V to 7 V
Output voltage range, V_O (see Note 1)	–0.5 V to $V_{CC} + 0.5$ V
Input clamp current, I_{IK} ($V_I < 0$)	–20 mA
Output clamp current, I_{OK} ($V_O < 0$ or $V_O > V_{CC}$)	±20 mA
Continuous output current, I_O ($V_O = 0$ to V_{CC})	±25 mA
Continuous current through V_{CC} or GND	±50 mA
Package thermal impedance, θ_{JA} (see Note 2): D package	113°C/W
DB package	131°C/W
DGV package	180°C/W
N package	78°C/W
PW package	149°C/W
Storage temperature range, T_{stg}	–65°C to 150°C

† Stresses beyond those listed under “absolute maximum ratings” may cause permanent damage to the device. These are stress ratings only, and functional operation of the device at these or any other conditions beyond those indicated under “recommended operating conditions” is not implied. Exposure to absolute-maximum-rated conditions for extended periods may affect device reliability.

- NOTES: 1. The input and output voltage ratings may be exceeded if the input and output current ratings are observed.
 2. The package thermal impedance is calculated in accordance with JESD 51, except for through-hole packages, which use a trace length of zero.

recommended operating conditions (see Note 3)

	SN54AHCT258		SN74AHCT258		UNIT
	MIN	MAX	MIN	MAX	
V_{CC} Supply voltage	4.5	5.5	4.5	5.5	V
V_{IH} High-level input voltage	2		2		V
V_{IL} Low-level input voltage		0.8		0.8	V
V_I Input voltage	0	5.5	0	5.5	V
V_O Output voltage	0	V_{CC}	0	V_{CC}	V
I_{OH} High-level output current		–8		–8	mA
I_{OL} Low-level output current		8		8	mA
$\Delta t/\Delta v$ Input transition rise or fall time		20		20	ns/V
T_A Operating free-air temperature	–55	125	–40	85	°C

NOTE 3: All unused inputs of the device must be held at V_{CC} or GND to ensure proper device operation. Refer to the TI application report, *Implications of Slow or Floating CMOS Inputs*, literature number SCBA004.

PRODUCT PREVIEW



SN54AHCT258, SN74AHCT258 QUADRUPLE 2-LINE TO 1-LINE DATA SELECTORS/MULTIPLEXERS WITH 3-STATE OUTPUTS

SCLS344E – MAY 1996 – REVISED OCTOBER 1998

electrical characteristics over recommended operating free-air temperature range (unless otherwise noted)

PARAMETER	TEST CONDITIONS	V _{CC}	T _A = 25°C			SN54AHCT258		SN74AHCT258		UNIT
			MIN	TYP	MAX	MIN	MAX	MIN	MAX	
V _{OH}	I _{OH} = -50 μA	4.5 V	4.4	4.5		4.4		4.4	V	
	I _{OH} = -8 mA		3.94			3.8		3.8		
V _{OL}	I _{OL} = 50 μA	4.5 V			0.1			0.1	V	
	I _{OL} = 8 mA				0.36		0.44	0.44		
I _I	V _I = V _{CC} or GND	5.5 V			±0.1		±1	±1	μA	
I _{CC}	V _I = V _{CC} or GND, I _O = 0	5.5 V			4		40	40	μA	
ΔI _{CC} †	One input at 3.4 V, Other inputs at V _{CC} or GND	5.5 V			1.35		1.5	1.5	mA	
I _{OZ}	V _O = V _{CC} or GND	5.5 V			±0.25		±2.5	±2.5	μA	
C _i	V _I = V _{CC} or GND	5 V							pF	

† This is the increase in supply current for each input at one of the specified TTL voltage levels rather than 0 V or V_{CC}.

switching characteristics over recommended operating free-air temperature range, V_{CC} = 5 V ± 0.5 V (unless otherwise noted) (see Figure 1)

PARAMETER	FROM (INPUT)	TO (OUTPUT)	LOAD CAPACITANCE	SN54AHCT258				UNIT	
				T _A = 25°C			MIN		MAX
				MIN	TYP	MAX			
t _{PLH} *	A or B	Y	C _L = 15 pF				ns		
t _{PHL} *									
t _{PLH} *	\bar{A}/B	Y	C _L = 15 pF				ns		
t _{PHL} *									
t _{PZH} *	\overline{OE}	Y	C _L = 15 pF				ns		
t _{PZL} *									
t _{PHZ} *	\overline{OE}	Y	C _L = 15 pF				ns		
t _{PLZ} *									
t _{PLH}	A or B	Y	C _L = 50 pF				ns		
t _{PHL}									
t _{PLH}	\bar{A}/B	Y	C _L = 50 pF				ns		
t _{PHL}									
t _{PZH}	\overline{OE}	Y	C _L = 50 pF				ns		
t _{PZL}									
t _{PHZ}	\overline{OE}	Y	C _L = 50 pF				ns		
t _{PLZ}									

* On products compliant to MIL-PRF-38535, this parameter is not production tested.

PRODUCT PREVIEW



SN54AHCT258, SN74AHCT258
**QUADRUPLE 2-LINE TO 1-LINE DATA SELECTORS/MULTIPLEXERS
 WITH 3-STATE OUTPUTS**

SCLS344E – MAY 1996 – REVISED OCTOBER 1998

switching characteristics over recommended operating free-air temperature range,
 $V_{CC} = 5\text{ V} \pm 0.5\text{ V}$ (unless otherwise noted) (see Figure 1)

PARAMETER	FROM (INPUT)	TO (OUTPUT)	LOAD CAPACITANCE	SN74AHCT258				UNIT	
				$T_A = 25^\circ\text{C}$			MIN		MAX
				MIN	TYP	MAX			
t _{PLH}	A or B	Y	C _L = 15 pF				ns		
t _{PHL}									
t _{PLH}	\bar{A}/B	Y	C _L = 15 pF				ns		
t _{PHL}									
t _{PZH}	\overline{OE}	Y	C _L = 15 pF				ns		
t _{PZL}									
t _{PHZ}	\overline{OE}	Y	C _L = 15 pF				ns		
t _{PLZ}									
t _{PLH}	A or B	Y	C _L = 50 pF				ns		
t _{PHL}									
t _{PLH}	\bar{A}/B	Y	C _L = 50 pF				ns		
t _{PLH}									
t _{PZH}	\overline{OE}	Y	C _L = 50 pF				ns		
t _{PZL}									
t _{PHZ}	\overline{OE}	Y	C _L = 50 pF				ns		
t _{PLZ}									

noise characteristics $V_{CC} = 5\text{ V}$, $C_L = 50\text{ pF}$, $T_A = 25^\circ\text{C}$ (see Note 4)

PARAMETER		SN74AHCT258			UNIT
		MIN	TYP	MAX	
V _{OL(P)}	Quiet output, maximum dynamic V _{OL}				V
V _{OL(V)}	Quiet output, minimum dynamic V _{OL}				V
V _{OH(V)}	Quiet output, minimum dynamic V _{OH}				V
V _{IH(D)}	High-level dynamic input voltage				V
V _{IL(D)}	Low-level dynamic input voltage				V

NOTE 4: Characteristics are for surface-mount packages only.

operating characteristics, $V_{CC} = 5\text{ V}$, $T_A = 25^\circ\text{C}$

PARAMETER		TEST CONDITIONS	TYP	UNIT
C _{pd}	Power dissipation capacitance	No load, f = 1 MHz		pF

PRODUCT PREVIEW



SN54AHCT258, SN74AHCT258 QUADRUPLE 2-LINE TO 1-LINE DATA SELECTORS/MULTIPLEXERS WITH 3-STATE OUTPUTS

SCLS344E – MAY 1996 – REVISED OCTOBER 1998

PARAMETER MEASUREMENT INFORMATION

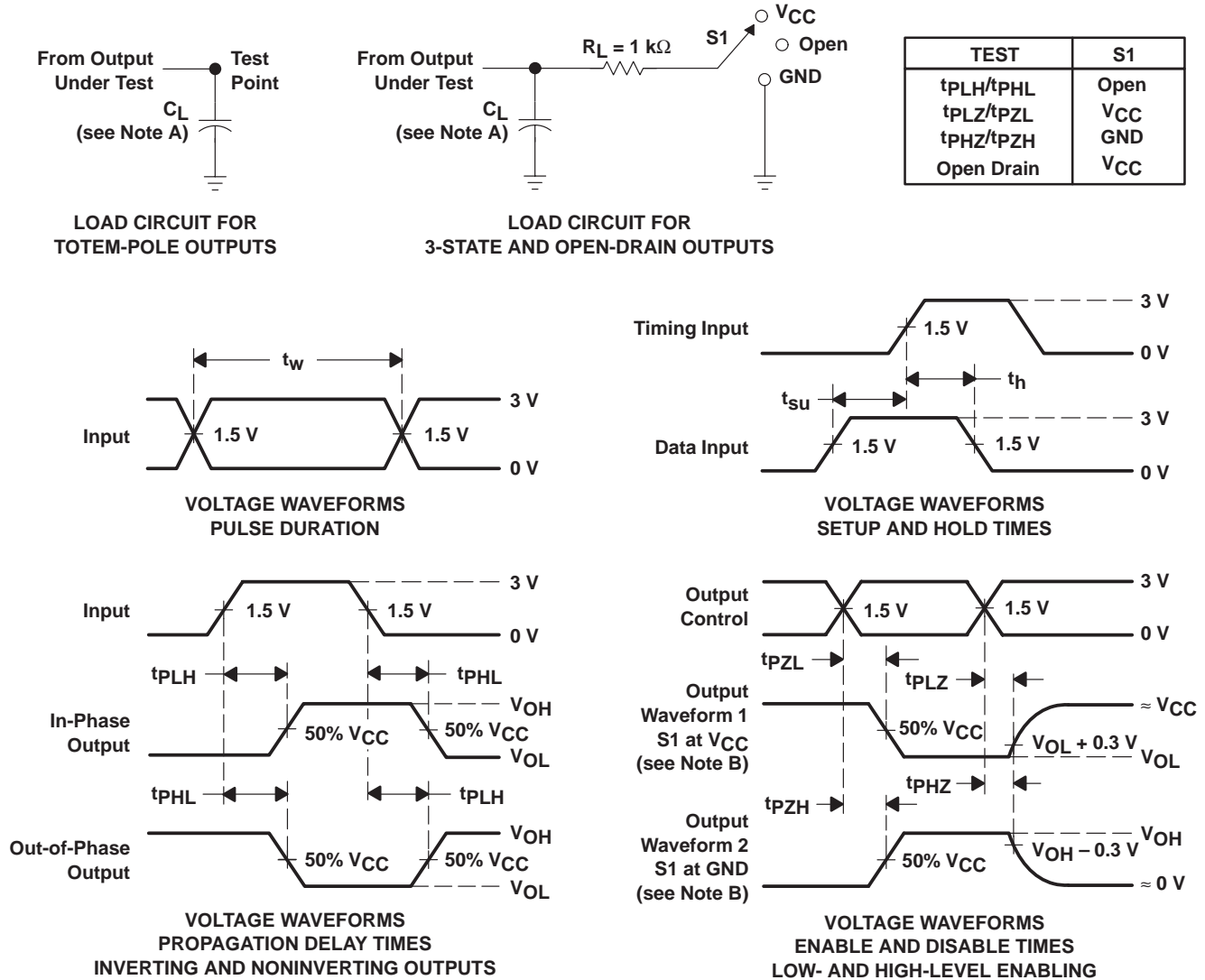

- NOTES:
- A. C_L includes probe and jig capacitance.
 - B. Waveform 1 is for an output with internal conditions such that the output is low except when disabled by the output control. Waveform 2 is for an output with internal conditions such that the output is high except when disabled by the output control.
 - C. All input pulses are supplied by generators having the following characteristics: $PRR \leq 1\text{ MHz}$, $Z_O = 50\ \Omega$, $t_r \leq 3\text{ ns}$, $t_f \leq 3\text{ ns}$.
 - D. The outputs are measured one at a time with one input transition per measurement.

Figure 1. Load Circuit and Voltage Waveforms

PRODUCT PREVIEW

IMPORTANT NOTICE

Texas Instruments and its subsidiaries (TI) reserve the right to make changes to their products or to discontinue any product or service without notice, and advise customers to obtain the latest version of relevant information to verify, before placing orders, that information being relied on is current and complete. All products are sold subject to the terms and conditions of sale supplied at the time of order acknowledgement, including those pertaining to warranty, patent infringement, and limitation of liability.

TI warrants performance of its semiconductor products to the specifications applicable at the time of sale in accordance with TI's standard warranty. Testing and other quality control techniques are utilized to the extent TI deems necessary to support this warranty. Specific testing of all parameters of each device is not necessarily performed, except those mandated by government requirements.

CERTAIN APPLICATIONS USING SEMICONDUCTOR PRODUCTS MAY INVOLVE POTENTIAL RISKS OF DEATH, PERSONAL INJURY, OR SEVERE PROPERTY OR ENVIRONMENTAL DAMAGE ("CRITICAL APPLICATIONS"). TI SEMICONDUCTOR PRODUCTS ARE NOT DESIGNED, AUTHORIZED, OR WARRANTED TO BE SUITABLE FOR USE IN LIFE-SUPPORT DEVICES OR SYSTEMS OR OTHER CRITICAL APPLICATIONS. INCLUSION OF TI PRODUCTS IN SUCH APPLICATIONS IS UNDERSTOOD TO BE FULLY AT THE CUSTOMER'S RISK.

In order to minimize risks associated with the customer's applications, adequate design and operating safeguards must be provided by the customer to minimize inherent or procedural hazards.

TI assumes no liability for applications assistance or customer product design. TI does not warrant or represent that any license, either express or implied, is granted under any patent right, copyright, mask work right, or other intellectual property right of TI covering or relating to any combination, machine, or process in which such semiconductor products or services might be or are used. TI's publication of information regarding any third party's products or services does not constitute TI's approval, warranty or endorsement thereof.