

PRODUCT NUMBER

XXXX-YYR

- SPECIAL OPTIONS (SEE NOTE 8 OR 14)
- NUMBER OF POSITIONS (SEE NOTE 3)
- 0 INDICATES PLATING (SEE NOTE 2)
- BASE PART NUMBER

$\text{M} \text{W} \text{V} \text{S}$

NOTE 4

$\square .025 \pm .001$
 $\square .64 \pm 0.03$
TYP

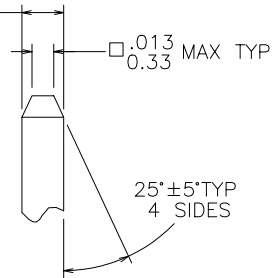

DETAIL P
TYP BOTH ENDS

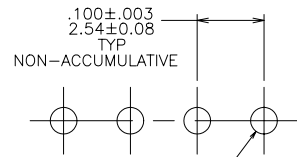

RECOMMENDED HOLE PATTERN

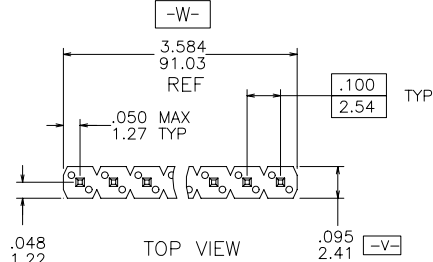

TOP VIEW

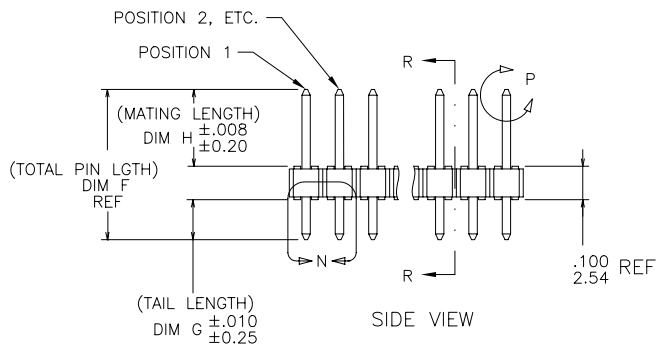

SIDE VIEW

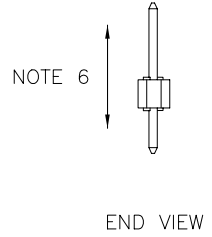

NOTE 6

END VIEW

mat'l. code NOTE 1 & 2		surface ISO 1302 ✓		tolerance ISO 406 ISO 1101		projection 		product family BERGSTIK	
ltr		ecn no		date		tolerances unless otherwise specified		title	
C	v61161	EPK	8/15/96	angles	linear	.xx ±.01/.3	INCH/MM	EconStik™ HEADER .100/2.54cc	
D	v61801	EPK	1/06/97			.xxx ±.005/.13		SINGLE ROW STRAIGHT	
E	v70087	HTB	1/17/97	σ±2'		.xxxx ±.0020/.051	scale 1:1	dwg no	
F	v70381	HTB	3/21/97	dr	T. BREWBAKER	3/23/94		sheet 1 of 3 size	
G	v70843	HTB	5/23/97	enr	T. HANNA	3/23/94		93115 A3	
H	v71584	HTB	11/12/97	chr	T. HANNA	3/23/94		type Product Customer Drawing	
J	M06-0270	AEA	7/14/06	appd	T. HANNA	3/23/94			
sheet index	revision	J	J	J					
	sheet	1	2	3					



FCIconnect.com

Copyright FCI

BERGSTRIPTM HEADER

REEL PACKING DIMENSIONS

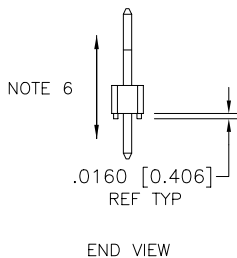
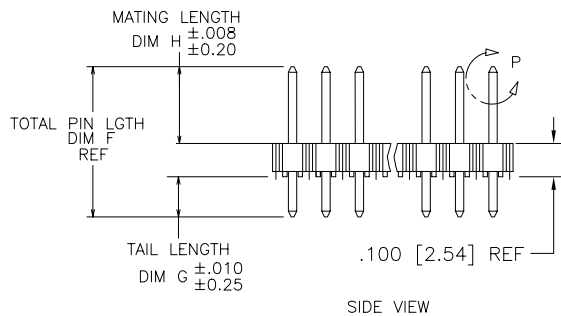
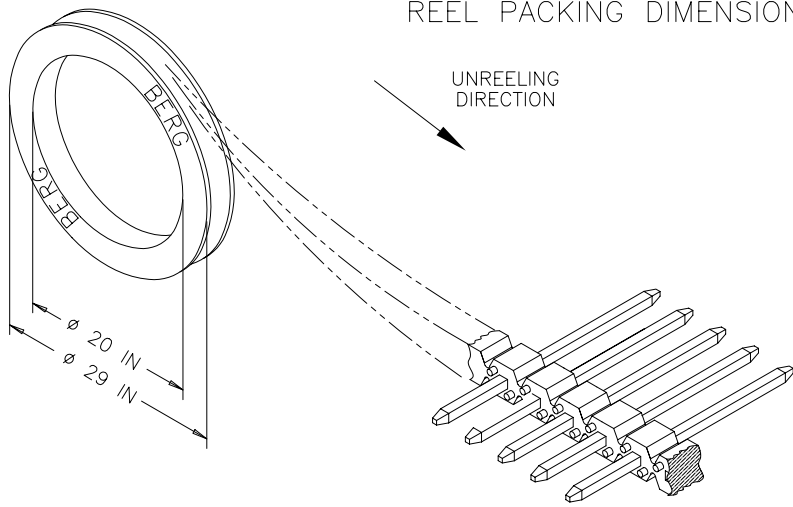
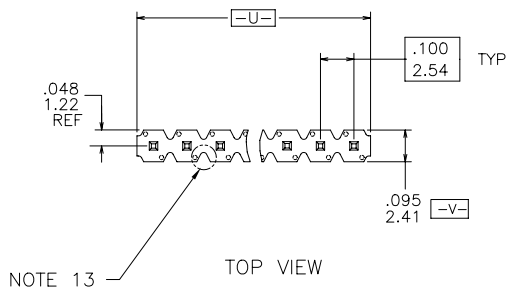

FCIconnect.com

Copyright FCI

mat'l. code		surface ISO 1302 ✓		tolerance ISO 406 ISO 1101		projection ⊕		product family BERGSTIK	
ltr	ecn	no	dr	date		tolerances unless otherwise specified		title	
J						angles	linear	EconStik™ HEADER .100/2.54cc	
						°±2'	.xx ±.01/.3 .xxx ±.005/.13 .xxxx ±.0020/.051	SINGLE ROW STRAIGHT	
								scale 2:1	
				dr E. KROPIEWNICKI 8/15/96				dwg no	
				enr T. BREWBAKER 8/15/96				93115	
				chr T. BREWBAKER 8/15/96				sheet 2 of 3 size	
				app T. BREWBAKER 8/15/96				A3	
sheet index		revision sheet						type Product Customer Drawing	

PRODUCT NUMBER	TOTAL PIN LENGTH		TAIL LENGTH		MATING LENGTH	
	DIM F	DIM F	DIM G	DIM G	DIM H	DIM H
	ENGLISH	METRIC	ENGLISH	METRIC	ENGLISH	METRIC
73531-0YY	0.425	10.80	0.095	2.41	0.230	5.84
93115-0YY	0.450	11.43	0.120	3.05	0.230	5.84

NOTES

- ①. BODY MATERIAL : 30% GLASS FIBER REINFORCED PCT FLAME RETARDANT PER UL-94V-0. COLOR: BLACK.
BERGSTRIPTM PRODUCED WITH HIGH TEMPERATURE LCP THERMOPLASTIC, FLAME RETARDANT PER UL-94V-0.
COLOR : BLACK
PIN MATERIAL : PHOS BRONZE
- ②. PIN PLATING : 2u"/0.05u Au over 50u"/1.27u min Ni.
- ③. AVAILABLE IN 2 (1X2) THRU 36 (1X36) POSITIONS.
-000 INDICATES BERGSTRIPTM PRODUCT. SEE PAGE 2 FOR SPECIAL GEOMETRY OF THIS CONTINUOUS STRIP PRODUCT. AUTOMATED REELS WILL CONTAIN 36,000 PINS.
- ④. MEASURED WITH PART IN RESTRAINED CONDITION.
- ⑤. PIN TIPS NOT PLATED. TYPICAL BOTH ENDS.
- ⑥. 2LBS/0.9KG MIN PIN RETENTION IN EITHER DIRECTION.
- ⑦. PACKAGE IN POLY BAGS.
- ⑧. EIGHT DIGIT PART NUMBERS FOLLOWED BY AN "R" INCLUDE RETENTION TAILS. NOT AVAILABLE ON BERGSTRIPTM CONTINUOUS STRIP.
- ⑨. DETAIL N DIMENSIONS ONLY APPLY TO 2 POSITION PARTS, OR 3, AND 4 POSITION PARTS WITH CENTER PINS POLARIZED.
- ⑩. SECTION R-R DIMENSIONS ONLY APPLY TO RETENTION PIN POSITIONS FOR 3 POSITION PARTS AND LARGER. RETENTION PIN POSITIONS LOCATED AT MANUFACTURES OPTION.
- ⑪. 5LB/2.3KG MAX INSERTION FORCE AND .25LB/.1KG MIN RETENTION FORCE PER RETENTIVE PIN USING .062/1.57 THICK CIRCUIT BOARDS AND RECOMMENDED HOLE PATTERN.
- ⑫. DIMENSIONS SHOWN ARE FOR 0.085/2.16 AND 0.120/3.05 TAILS ONLY. THESE DIMENSIONS CANNOT BE GUARANTEED ON ANY OTHER TAIL LENGTHS.
- ⑬. NOTCH CONFIGURATION WILL VARY PER VENDOR'S DISCRETION.
- ⑭. BERGSTRIPTM PART NUMBERS FOLLOWED BY A "B" ARE BULK PRICED.

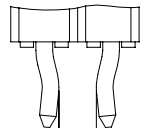

.056±.003
1.42±0.08

DETAIL N
TWO POSITION
NOTE 9 & 12

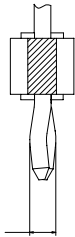

.039±.003
0.99±0.08

SECTION R-R
NOTE 10 & 12

mat'l. code		surface ISO 1302 ✓		tolerance ISO 406 ISO 1101		projection ⊕		product family BERGSTIK	
ltr	ecn	no	dr	date	tolerances unless otherwise specified		title		
J					angles	linear	.xx ±.01/.3	INCH/MM	EconStik™ HEADER .100/2.54cc
					0°±2'		.xxx ±.005/.13	scale 2:1	SINGLE ROW STRAIGHT
							.xxx ±.0020/.051		
					dr	E. KROPIEWNICK	1/06/97	FCI	dwg no
					enr	M. SMYK	1/06/97		sheet 3 of 3
					chr	T. BREWBAKER	1/06/97		size
					app'd	T. BREWBAKER	1/06/97		A3
sheet index	revision sheet								type Product Customer Drawing