

**LOW DROP FIXED AND ADJUSTABLE  
POSITIVE VOLTAGE REGULATORS**

PRELIMINARY DATA

- LOW DROPOUT VOLTAGE (1V TYP)
- 2.85V DEVICE PERFORMANCES ARE SUITABLE FOR SCSI-2 ACTIVE TERMINATION
- OUTPUT CURRENT UP TO 800mA
- FIXED OUTPUT VOLTAGE OF: 2.5V, 2.85V, 3.0V, 3.3V, 5.0V
- ADJUSTABLE VERSION AVAILABILITY ( $V_{ref}=1.25V$ )
- INTERNAL CURRENT AND THERMAL LIMIT
- AVAILABLE IN  $\pm 1\%$  (AT 25°C) AND 2% IN ALL TEMPERATURE RANGE
- SUPPLY VOLTAGE REJECTION : 75 dB (TYP)
- TEMPERATURE RANGE : 0°C TO 125°C

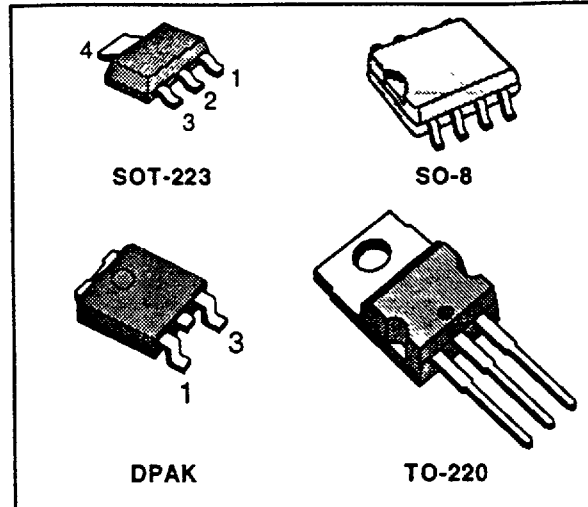

**DESCRIPTION**

The LD1117 is a LOW DROP Voltage Regulator able to provide up to 800mA of Output Current, available even in adjustable version ( $V_{ref}=1.25V$ ). Concerning fixed versions, are offered the following Output Voltages: 2.5V, 2.85V, 3.0V 3.3V and 5.0V. The 2.85V type is ideal for SCSI-2 lines active termination. The device is supplied in: SOT-223, DPAK, SO-8 and TO-220. The SOT-223 and DPAK surface mount packages optimize the thermal characteristics even offering a relevant space saving effect. High efficiency is assured by NPN

pass transistor. In fact in this case, unlike than PNP one, the Quiescent Current flows mostly into the load. Only a very common 10 $\mu$ F minimum capacitor is needed for stability. On chip trimming allows the regulator to reach a very tight output voltage tolerance, within  $\pm 1\%$  at 25 °C. The ADJUSTABLE LD1117 is pin to pin compatible with the other standard Adjustable voltage regulators maintaining the better performances in terms of Drop and Tolerance.

**BLOCK DIAGRAM**

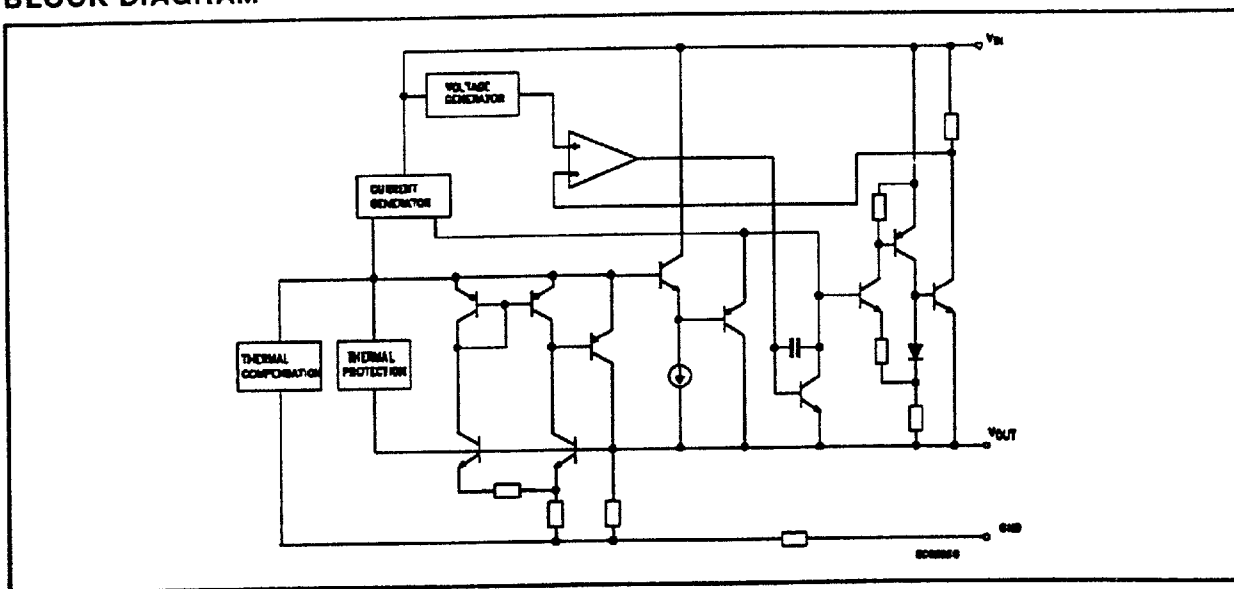

**ABSOLUTE MAXIMUM RATINGS**

Symbol	Parameter	Value	Unit
$V_{IN}$	DC Input Voltage	20	V
$I_o$	Output Current	Internally Limited	mA
$P_{tot}$	Power Dissipation	Internally Limited	mA
$T_{stg}$	Storage Temperature Range	-40 to 150	°C
$T_{op}$	Operating Junction Temperature Range	0 to 125	°C

Absolute Maximum Ratings are those value beyond which damage to the device may occur. Functional operation under these condition is not implied.

**THERMAL DATA**

Symbol	Parameter	SOT-223	SO-8	DPAK	TO-220	Unit
$R_{th-case}$	Thermal Resistance Junction-case	15	20	8	3	°C/W
$R_{th-amb}$	Thermal Resistance Junction-ambient				50	°C/W

**APPLICATION CIRCUIT**

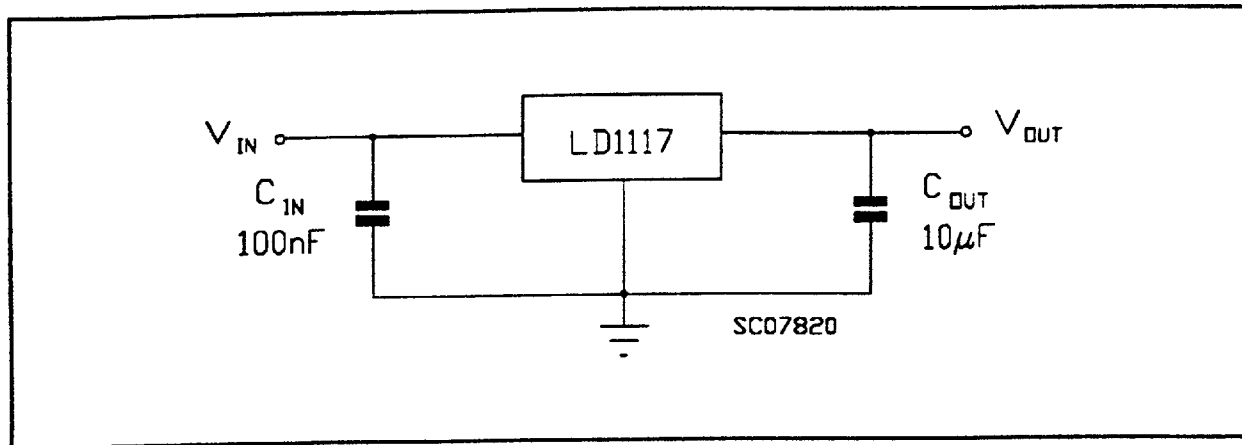

CONNECTION DIAGRAM AND ORDERING NUMBERS (top view)

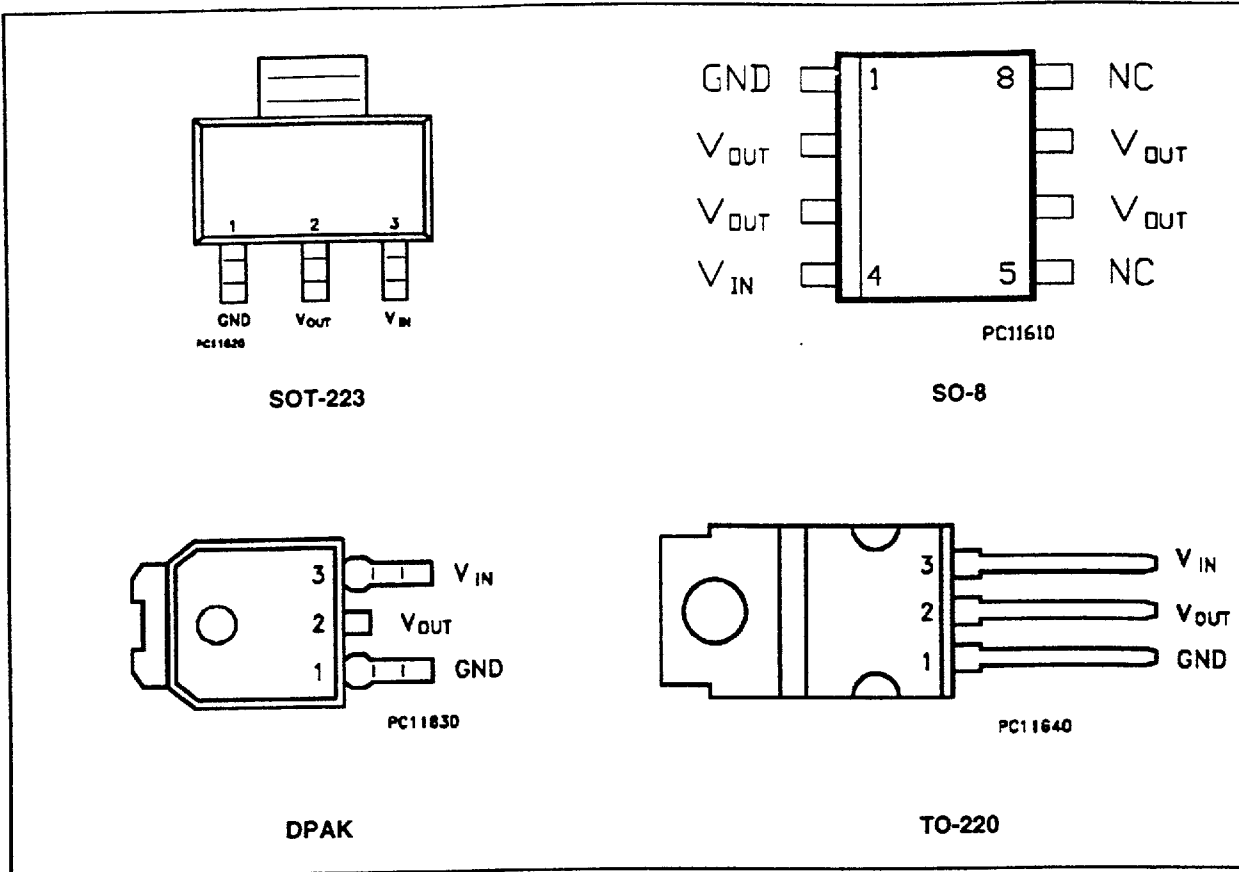

SOT-223	SO-8	DPAK	TO-220	Output Voltage
LD1117S25	LD1117D25	LD1117DT25	LD1117V25	2.5V
LD1117S25C	LD1117D25C	LD1117DT25C	LD1117V25C	2.5V
LD1117S285	LD1117D285	LD1117DT285	LD1117V285	2.85V
LD1117S30	LD1117D30	LD1117DT30	LD1117V30	3V
LD1117S30C	LD1117D30C	LD1117DT30C	LD1117V30C	3V
LD1117S33	LD1117D33	LD1117DT33	LD1117V33	3.3V
LD1117S33C	LD1117D33C	LD1117DT33C	LD1117V33C	3.3V
LD1117S50	LD1117D50	LD1117DT50	LD1117V50	5V
LD1117S50C	LD1117D50C	LD1117DT50C	LD1117V50C	5V
LD1117S	LD1117D	LD1117DT	LD1117V	ADJUSTABLE FROM 1.25 TO 15V

**ELECTRICAL CHARACTERISTICS FOR LD1117#25** (refer to the test circuits,  
 $P_D \leq 5W$ ;  $T_j = 0$  to  $125^\circ C$ ,  $C_o = 10 \mu F$  unless otherwise specified)

Symbol	Parameter	Test Conditions	Min.	Typ.	Max.	Unit
$V_o$	Output Voltage	$V_{in} = 4.5 V$ $I_o = 10 mA$ $T_j = 25^\circ C$	2.475	2.5	2.525	V
$V_o$	Output Voltage	$I_o = 0$ to $800 mA$ $V_{in} = 4.25$ to $10 V$ $I_o = 0$ to $500 mA$ $V_{in} = 4 V$	2.45 2.45		2.55 2.55	V V
$\Delta V_o$	Line Regulation	$V_{in} = 3.9$ to $10 V$ $I_o = 0 mA$		1	6	mV
$\Delta V_o$	Load Regulation	$V_{in} = 3.9 V$ $I_o = 0$ to $800 mA$		1	10	mV
$\Delta V_o$	Temperature Stability			0.5		%
$\Delta V_o$	Long Term Stability	1000 hrs $T_j = 125^\circ C$		0.3		%
$V_{in}$	Operating Input Voltage	$I_o = 100 mA$			15	V
$I_d$	Quiescent Current	$V_{in} \leq 10 V$		5	10	mA
$I_o$	Output Current	$V_{in} = 7.5 V$	800	950	1200	mA
eN	Output Noise Voltage	$B = 10Hz$ to $10KHz$ $T_j = 25^\circ C$		100		$\mu V$
SVR	Supply Voltage Rejection	$I_o = 40 mA$ $f = 120 Hz$ $T_j = 25^\circ C$ $V_{in} = 5.5 V$ $V_{ripple} = 1 V_{pp}$	60	75		dB
$V_d$	Dropout Voltage	$I_o = 100 mA$ $I_o = 500 mA$ $I_o = 800 mA$		1 1.05 1.15	1.1 1.2 1.3	V V V

**ELECTRICAL CHARACTERISTICS FOR LD1117#285** (refer to the test circuits,  
 $P_D \leq 5W$ ;  $T_j = 0$  to  $125^\circ C$ ,  $C_o = 10 \mu F$  unless otherwise specified)

Symbol	Parameter	Test Conditions	Min.	Typ.	Max.	Unit
$V_o$	Output Voltage	$V_{in} = 4.85 V$ $I_o = 10 mA$ $T_j = 25^\circ C$	2.82	2.85	2.88	V
$V_o$	Output Voltage	$I_o = 0$ to $800 mA$ $V_{in} = 4.25$ to $10 V$ $I_o = 0$ to $500 mA$ $V_{in} = 4 V$	2.79 2.79		2.91 2.91	V V
$\Delta V_o$	Line Regulation	$V_{in} = 4.25$ to $10 V$ $I_o = 0 mA$		1	6	mV
$\Delta V_o$	Load Regulation	$V_{in} = 4.25 V$ $I_o = 0$ to $800 mA$		1	10	mV
$\Delta V_o$	Temperature Stability			0.5		%
$\Delta V_o$	Long Term Stability	1000 hrs $T_j = 125^\circ C$		0.3		%
$V_{in}$	Operating Input Voltage	$I_o = 100 mA$			15	V
$I_d$	Quiescent Current	$V_{in} \leq 10 V$		5	10	mA
$I_o$	Output Current	$V_{in} = 7.85 V$	800	950	1200	mA
eN	Output Noise Voltage	$B = 10Hz$ to $10KHz$ $T_j = 25^\circ C$		100		$\mu V$
SVR	Supply Voltage Rejection	$I_o = 40 mA$ $f = 120 Hz$ $T_j = 25^\circ C$ $V_{in} = 5.85 V$ $V_{ripple} = 1 V_{pp}$	60	75		dB
$V_d$	Dropout Voltage	$I_o = 100 mA$ $I_o = 500 mA$ $I_o = 800 mA$		1 1.05 1.15	1.1 1.2 1.3	V V V

**ELECTRICAL CHARACTERISTICS FOR LD1117#30** (refer to the test circuits,  
 $P_D \leq 5W$ ;  $T_j = 0$  to  $125^\circ C$ ,  $C_o = 10 \mu F$  unless otherwise specified)

Symbol	Parameter	Test Conditions	Min.	Typ.	Max.	Unit
$V_o$	Output Voltage	$V_{in} = 5 V$ $I_o = 10 mA$ $T_j = 25^\circ C$	2.97	3	3.03	V
$V_o$	Output Voltage	$I_o = 0$ to $800 mA$ $V_{in} = 4.5$ to $10 V$ $I_o = 0$ to $500 mA$ $V_{in} = 4.2 V$	2.94 2.94		3.06 3.06	V V
$\Delta V_o$	Line Regulation	$V_{in} = 4.5$ to $12 V$ $I_o = 0 mA$		1	7	mV
$\Delta V_o$	Load Regulation	$V_{in} = 4.5 V$ $I_o = 0$ to $800 mA$		1	12	mV
$\Delta V_o$	Temperature Stability			0.5		%
$\Delta V_o$	Long Term Stability	1000 hrs $T_j = 125^\circ C$		0.3		%
$V_{in}$	Operating Input Voltage	$I_o = 100 mA$			15	V
$I_d$	Quiescent Current	$V_{in} \leq 12 V$		5	10	mA
$I_o$	Output Current	$V_{in} = 8 V$	800	950	1200	mA
eN	Output Noise Voltage	$B = 10Hz$ to $10KHz$ $T_j = 25^\circ C$		100		$\mu V$
SVR	Supply Voltage Rejection	$I_o = 40 mA$ $f = 120 Hz$ $T_j = 25^\circ C$ $V_{in} = 6 V$ $V_{ripple} = 1 V_{pp}$	60	75		dB
$V_d$	Dropout Voltage	$I_o = 100 mA$ $I_o = 500 mA$ $I_o = 800 mA$		1 1.05 1.15	1.1 1.2 1.3	V V V

**ELECTRICAL CHARACTERISTICS FOR LD1117#33** (refer to the test circuits,  
 $P_D \leq 5W$ ;  $T_j = 0$  to  $125^\circ C$ ,  $C_o = 10 \mu F$  unless otherwise specified)

Symbol	Parameter	Test Conditions	Min.	Typ.	Max.	Unit
$V_o$	Output Voltage	$V_{in} = 5.3 V$ $I_o = 10 mA$ $T_j = 25^\circ C$	3.27	3.3	3.33	V
$V_o$	Output Voltage	$I_o = 0$ to $800 mA$ $V_{in} = 4.8$ to $10 V$ $I_o = 0$ to $500 mA$ $V_{in} = 4.5 V$	3.24 3.24		3.36 3.36	V V
$\Delta V_o$	Line Regulation	$V_{in} = 4.8$ to $12 V$ $I_o = 0 mA$		1	7	mV
$\Delta V_o$	Load Regulation	$V_{in} = 4.8 V$ $I_o = 0$ to $800 mA$		1	12	mV
$\Delta V_o$	Temperature Stability			0.5		%
$\Delta V_o$	Long Term Stability	1000 hrs $T_j = 125^\circ C$		0.3		%
$V_{in}$	Operating Input Voltage	$I_o = 100 mA$			15	V
$I_d$	Quiescent Current	$V_{in} \leq 12 V$		5	10	mA
$I_o$	Output Current	$V_{in} = 8.3 V$	800	950	1200	mA
eN	Output Noise Voltage	$B = 10Hz$ to $10KHz$ $T_j = 25^\circ C$		100		$\mu V$
SVR	Supply Voltage Rejection	$I_o = 40 mA$ $f = 120 Hz$ $T_j = 25^\circ C$ $V_{in} = 6.3 V$ $V_{ripple} = 1 V_{pp}$	60	75		dB
$V_d$	Dropout Voltage	$I_o = 100 mA$ $I_o = 500 mA$ $I_o = 800 mA$		1 1.05 1.15	1.1 1.2 1.3	V V V

**ELECTRICAL CHARACTERISTICS FOR LD1117#50** (refer to the test circuits,  
 $P_D \leq 5W$ ;  $T_j = 0$  to  $125^\circ C$ ,  $C_o = 10 \mu F$  unless otherwise specified)

Symbol	Parameter	Test Conditions	Min.	Typ.	Max.	Unit
$V_o$	Output Voltage	$V_{in} = 7 V$ $I_o = 10 mA$ $T_j = 25^\circ C$	4.95	5	5.05	V
$V_o$	Output Voltage	$I_o = 0$ to $800 mA$ $V_{in} = 6.5$ to $15 V$ $I_o = 0$ to $500 mA$ $V_{in} = 6.2 V$	4.9 4.9		5.1 5.1	V V
$\Delta V_o$	Line Regulation	$V_{in} = 6.5$ to $15 V$ $I_o = 0 mA$		1	10	mV
$\Delta V_o$	Load Regulation	$V_{in} = 6.5 V$ $I_o = 0$ to $800 mA$		1	15	mV
$\Delta V_o$	Temperature Stability			0.5		%
$\Delta V_o$	Long Term Stability	1000 hrs $T_j = 125^\circ C$		0.3		%
$V_{in}$	Operating Input Voltage	$I_o = 100 mA$			15	V
$I_d$	Quiescent Current	$V_{in} \leq 15 V$		5	10	mA
$I_o$	Output Current	$V_{in} = 11 V$	800	950	1200	mA
eN	Output Noise Voltage	$B = 10Hz$ to $10KHz$ $T_j = 25^\circ C$		100		$\mu V$
SVR	Supply Voltage Rejection	$I_o = 40 mA$ $f = 120 Hz$ $T_j = 25^\circ C$ $V_{in} = 8 V$ $V_{ripple} = 1 V_{pp}$	60	75		dB
$V_d$	Dropout Voltage	$I_o = 100 mA$ $I_o = 500 mA$ $I_o = 800 mA$		1 1.05 1.15	1.1 1.2 1.3	V V V

**ELECTRICAL CHARACTERISTICS FOR LD1117(ADJUSTABLE)** (refer to the test circuits,  
 $P_D \leq 5W$ ;  $T_j = 0$  to  $125^\circ C$ ,  $C_o = 10 \mu F$  unless otherwise specified)

Symbol	Parameter	Test Conditions	Min.	Typ.	Max.	Unit
$V_{ref}$	Reference Voltage	$V_{in} - V_o = 2 V$ $I_o = 10 mA$ $T_j = 25^\circ C$	1.238	1.25	1.262	V
$V_{ref}$	Reference Voltage	$I_o = 10$ to $800 mA$ $V_{in} - V_o = 1.5$ to $10 V$	1.225		1.275	V
$\Delta V_o$	Line Regulation	$V_{in} - V_o = 1.5$ to $10 V$ $I_o = 10 mA$		1	5	mV
$\Delta V_o$	Load Regulation	$V_{in} - V_o = 3 V$ $I_o = 0$ to $800 mA$		1	10	mV
$\Delta V_o$	Temperature Stability			0.5		%
$\Delta V_o$	Long Term Stability	1000 hrs $T_j = 125^\circ C$		0.3		%
$V_{in} - V_o$	Input Output Differential Voltage				15	V
$\Delta I_{adj}$	Adjustment Pin Current Change	$V_{in} - V_o = 1.5$ to $10 V$ $I_o = 10$ to $800 mA$			5	$\mu A$
$I_{o(min)}$	Minimum Load Current	$V_{in} - V_o = 15 V$			5	mA
$I_d$	Quiescent Current	$V_{in} - V_o \leq 10 V$			120	$\mu A$
$I_o$	Output Current	$V_{in} - V_o = 5 V$	800	950	1200	mA
eN	Output Noise (% $V_o$ )	$B = 10Hz$ to $10KHz$ $T_j = 25^\circ C$		0.003		%
SVR	Supply Voltage Rejection	$I_o = 40 mA$ $f = 120 Hz$ $T_j = 25^\circ C$ $V_{in} - V_o = 3 V$ $V_{ripple} = 1 V_{pp}$	60	75		dB
$V_d$	Dropout Voltage	$I_o = 100 mA$ $I_o = 500 mA$ $I_o = 800 mA$		1 1.05 1.15	1.1 1.2 1.3	V V V

**ELECTRICAL CHARACTERISTICS FOR LD1117#25C** (refer to the test circuits,  
 $P_D \leq 5W$ ;  $T_j = 0$  to  $125^\circ C$ ,  $C_o = 10 \mu F$  unless otherwise specified)

Symbol	Parameter	Test Conditions	Min.	Typ.	Max.	Unit
$V_o$	Output Voltage	$V_{in} = 4.5 V$ $I_o = 10 mA$ $T_j = 25^\circ C$	2.45	2.5	2.55	V
$V_o$	Output Voltage	$I_o = 0$ to $800 mA$ $V_{in} = 4.25$ to $10 V$ $I_o = 0$ to $500 mA$ $V_{in} = 4 V$	2.4 2.4		2.6 2.6	V V
$\Delta V_o$	Line Regulation	$V_{in} = 3.9$ to $10 V$ $I_o = 0 mA$		1	6	mV
$\Delta V_o$	Load Regulation	$V_{in} = 3.9 V$ $I_o = 0$ to $800 mA$		1	10	mV
$\Delta V_o$	Temperature Stability			0.5		%
$\Delta V_o$	Long Term Stability	1000 hrs $T_j = 125^\circ C$		0.3		%
$V_{in}$	Operating Input Voltage	$I_o = 100 mA$			15	V
$I_d$	Quiescent Current	$V_{in} \leq 10 V$		5	10	mA
$I_o$	Output Current	$V_{in} = 7.5 V$	800	950	1200	mA
eN	Output Noise Voltage	$B = 10Hz$ to $10KHz$ $T_j = 25^\circ C$		100		$\mu V$
SVR	Supply Voltage Rejection	$I_o = 40 mA$ $f = 120 Hz$ $T_j = 25^\circ C$ $V_{in} = 5.5 V$ $V_{ripple} = 1 V_{pp}$	60	75		dB
$V_d$	Dropout Voltage	$I_o = 100 mA$ $I_o = 500 mA$ $I_o = 800 mA$		1 1.05 1.15	1.1 1.2 1.3	V V V

**ELECTRICAL CHARACTERISTICS FOR LD1117#30C** (refer to the test circuits,  
 $P_D \leq 5W$ ;  $T_j = 0$  to  $125^\circ C$ ,  $C_o = 10 \mu F$  unless otherwise specified)

Symbol	Parameter	Test Conditions	Min.	Typ.	Max.	Unit
$V_o$	Output Voltage	$V_{in} = 5 V$ $I_o = 10 mA$ $T_j = 25^\circ C$	2.94	3	3.06	V
$V_o$	Output Voltage	$I_o = 0$ to $800 mA$ $V_{in} = 4.5$ to $10 V$ $I_o = 0$ to $500 mA$ $V_{in} = 4.2 V$	2.88 2.88		3.12 3.12	V V
$\Delta V_o$	Line Regulation	$V_{in} = 4.5$ to $12 V$ $I_o = 0 mA$		1	30	mV
$\Delta V_o$	Load Regulation	$V_{in} = 4.5 V$ $I_o = 0$ to $800 mA$		1	30	mV
$\Delta V_o$	Temperature Stability			0.5		%
$\Delta V_o$	Long Term Stability	1000 hrs $T_j = 125^\circ C$		0.3		%
$V_{in}$	Operating Input Voltage	$I_o = 100 mA$			15	V
$I_d$	Quiescent Current	$V_{in} \leq 12 V$		5	10	mA
$I_o$	Output Current	$V_{in} = 8 V$	800	950	1200	mA
eN	Output Noise Voltage	$B = 10Hz$ to $10KHz$ $T_j = 25^\circ C$		100		$\mu V$
SVR	Supply Voltage Rejection	$I_o = 40 mA$ $f = 120 Hz$ $T_j = 25^\circ C$ $V_{in} = 6 V$ $V_{ripple} = 1 V_{pp}$	60	75		dB
$V_d$	Dropout Voltage	$I_o = 100 mA$ $I_o = 500 mA$ $I_o = 800 mA$		1 1.05 1.15	1.1 1.2 1.3	V V V

**ELECTRICAL CHARACTERISTICS FOR LD1117#33C** (refer to the test circuits,  
 $P_D \leq 5W$ ;  $T_j = 0$  to  $125^\circ C$ ,  $C_o = 10 \mu F$  unless otherwise specified)

Symbol	Parameter	Test Conditions	Min.	Typ.	Max.	Unit
$V_o$	Output Voltage	$V_{in} = 5.3 V$ $I_o = 10 mA$ $T_j = 25^\circ C$	3.24	3.3	3.36	V
$V_o$	Output Voltage	$I_o = 0$ to $800 mA$ $V_{in} = 4.8$ to $10 V$ $I_o = 0$ to $500 mA$ $V_{in} = 4.5 V$	3.16 3.16		3.43 3.43	V V
$\Delta V_o$	Line Regulation	$V_{in} = 4.8$ to $12 V$ $I_o = 0 mA$		1	30	mV
$\Delta V_o$	Load Regulation	$V_{in} = 4.8 V$ $I_o = 0$ to $800 mA$		1	30	mV
$\Delta V_o$	Temperature Stability			0.5		%
$\Delta V_o$	Long Term Stability	1000 hrs $T_j = 125^\circ C$		0.3		%
$V_{in}$	Operating Input Voltage	$I_o = 100 mA$			15	V
$I_d$	Quiescent Current	$V_{in} \leq 12 V$		5	10	mA
$I_o$	Output Current	$V_{in} = 8.3 V$	800	950	1200	mA
eN	Output Noise Voltage	$B = 10Hz$ to $10KHz$ $T_j = 25^\circ C$		100		$\mu V$
SVR	Supply Voltage Rejection	$I_o = 40 mA$ $f = 120 Hz$ $T_j = 25^\circ C$ $V_{in} = 6.3 V$ $V_{ripple} = 1 V_{pp}$	60	75		dB
$V_d$	Dropout Voltage	$I_o = 100 mA$ $I_o = 500 mA$ $I_o = 800 mA$		1 1.05 1.15	1.1 1.2 1.3	V V V

**ELECTRICAL CHARACTERISTICS FOR LD1117#50C** (refer to the test circuits,  
 $P_D \leq 5W$ ;  $T_j = 0$  to  $125^\circ C$ ,  $C_o = 10 \mu F$  unless otherwise specified)

Symbol	Parameter	Test Conditions	Min.	Typ.	Max.	Unit
$V_o$	Output Voltage	$V_{in} = 7 V$ $I_o = 10 mA$ $T_j = 25^\circ C$	4.9	5	5.1	V
$V_o$	Output Voltage	$I_o = 0$ to $800 mA$ $V_{in} = 6.5$ to $15 V$ $I_o = 0$ to $500 mA$ $V_{in} = 6.2 V$	4.8 4.8		5.2 5.2	V V
$\Delta V_o$	Line Regulation	$V_{in} = 6.5$ to $15 V$ $I_o = 0 mA$		1	50	mV
$\Delta V_o$	Load Regulation	$V_{in} = 6.5 V$ $I_o = 0$ to $800 mA$		1	50	mV
$\Delta V_o$	Temperature Stability			0.5		%
$\Delta V_o$	Long Term Stability	1000 hrs $T_j = 125^\circ C$		0.3		%
$V_{in}$	Operating Input Voltage	$I_o = 100 mA$			15	V
$I_d$	Quiescent Current	$V_{in} \leq 15 V$		5	10	mA
$I_o$	Output Current	$V_{in} = 11 V$	800	950	1200	mA
eN	Output Noise Voltage	$B = 10Hz$ to $10KHz$ $T_j = 25^\circ C$		100		$\mu V$
SVR	Supply Voltage Rejection	$I_o = 40 mA$ $f = 120 Hz$ $T_j = 25^\circ C$ $V_{in} = 8 V$ $V_{ripple} = 1 V_{pp}$	60	75		dB
$V_d$	Dropout Voltage	$I_o = 100 mA$ $I_o = 500 mA$ $I_o = 800 mA$		1 1.05 1.15	1.1 1.2 1.3	V V V



TYPICAL APPLICATIONS:

FIGURE 1: Neative Supply

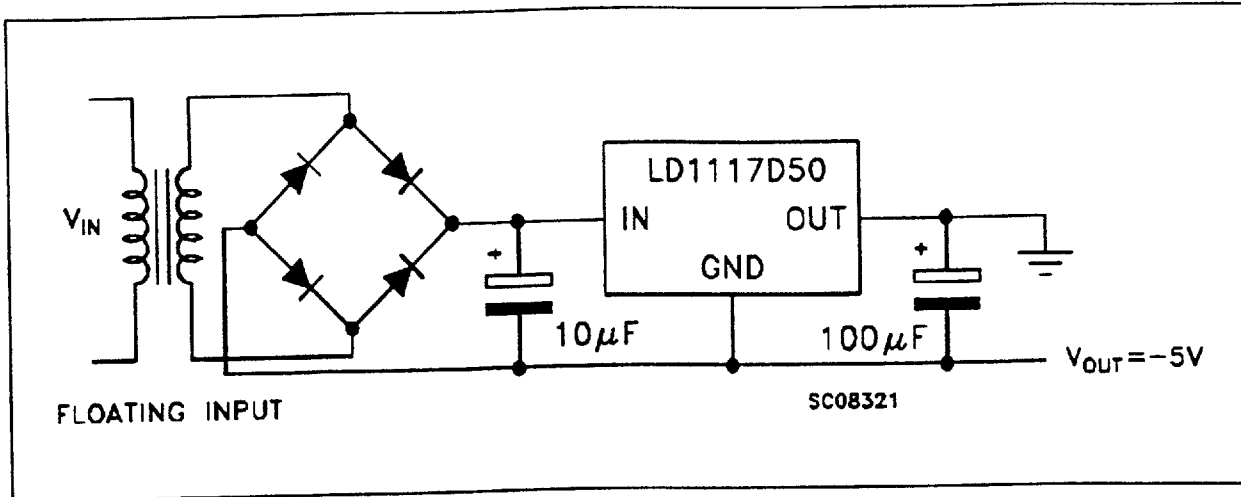

FIGURE 2: Active Terminator for SCSI-2 BUS

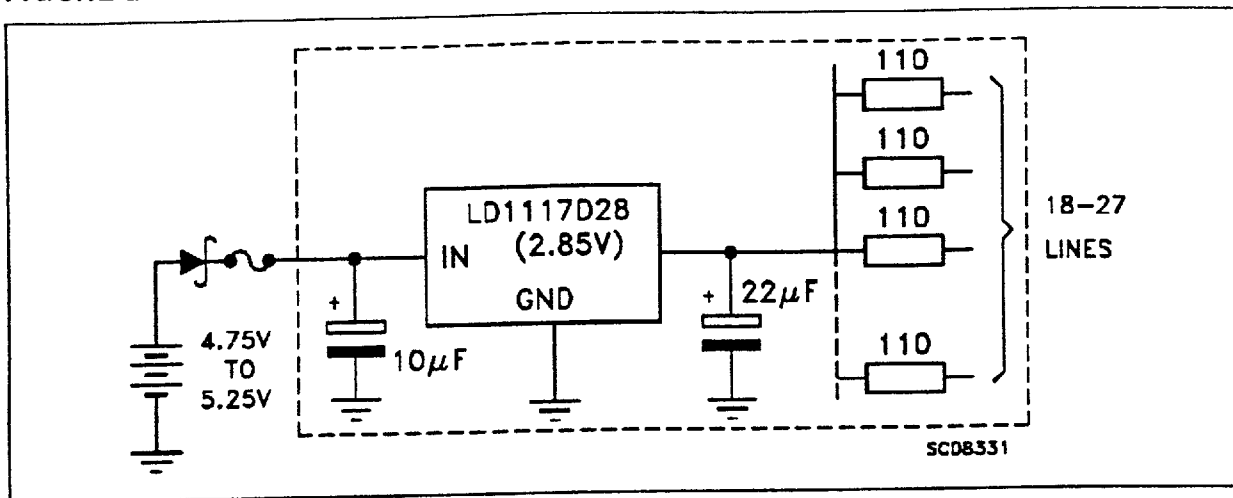
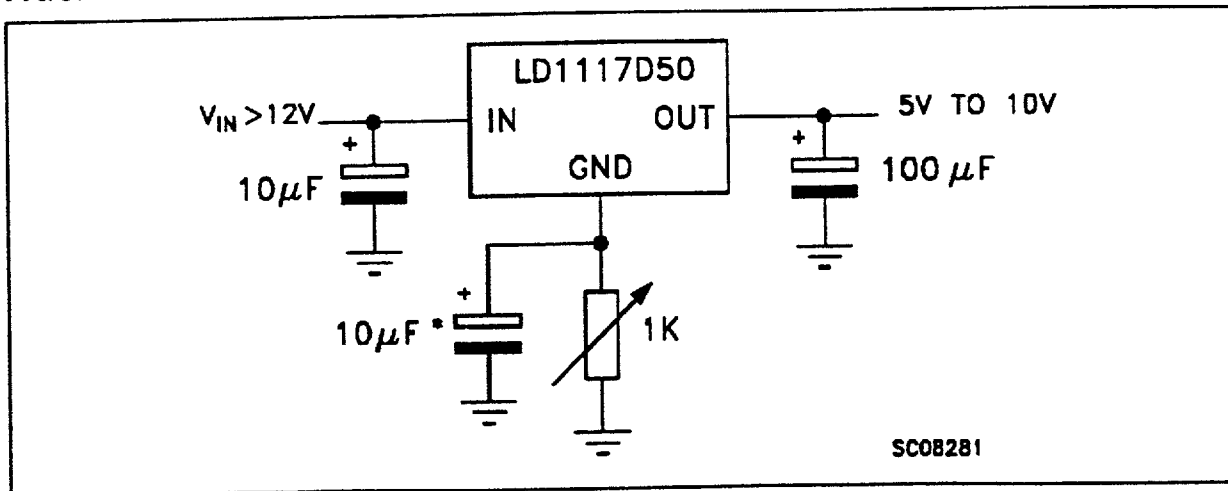

FIGURE 3: Circuit for Increasing Output Voltage



TYPICAL APPLICATIONS (continued):

FIGURE 4: Voltage Regulator With Reference

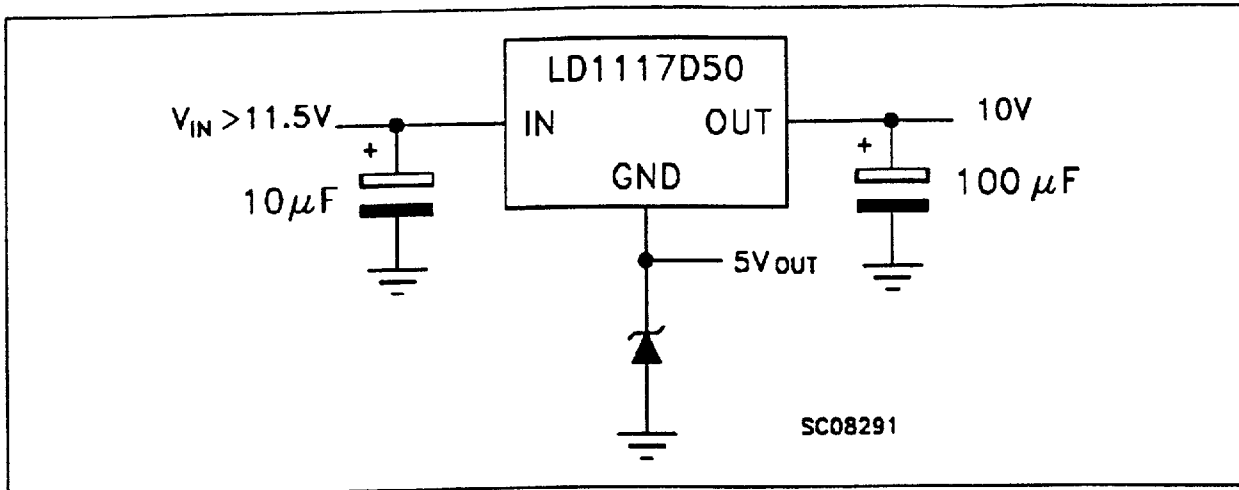
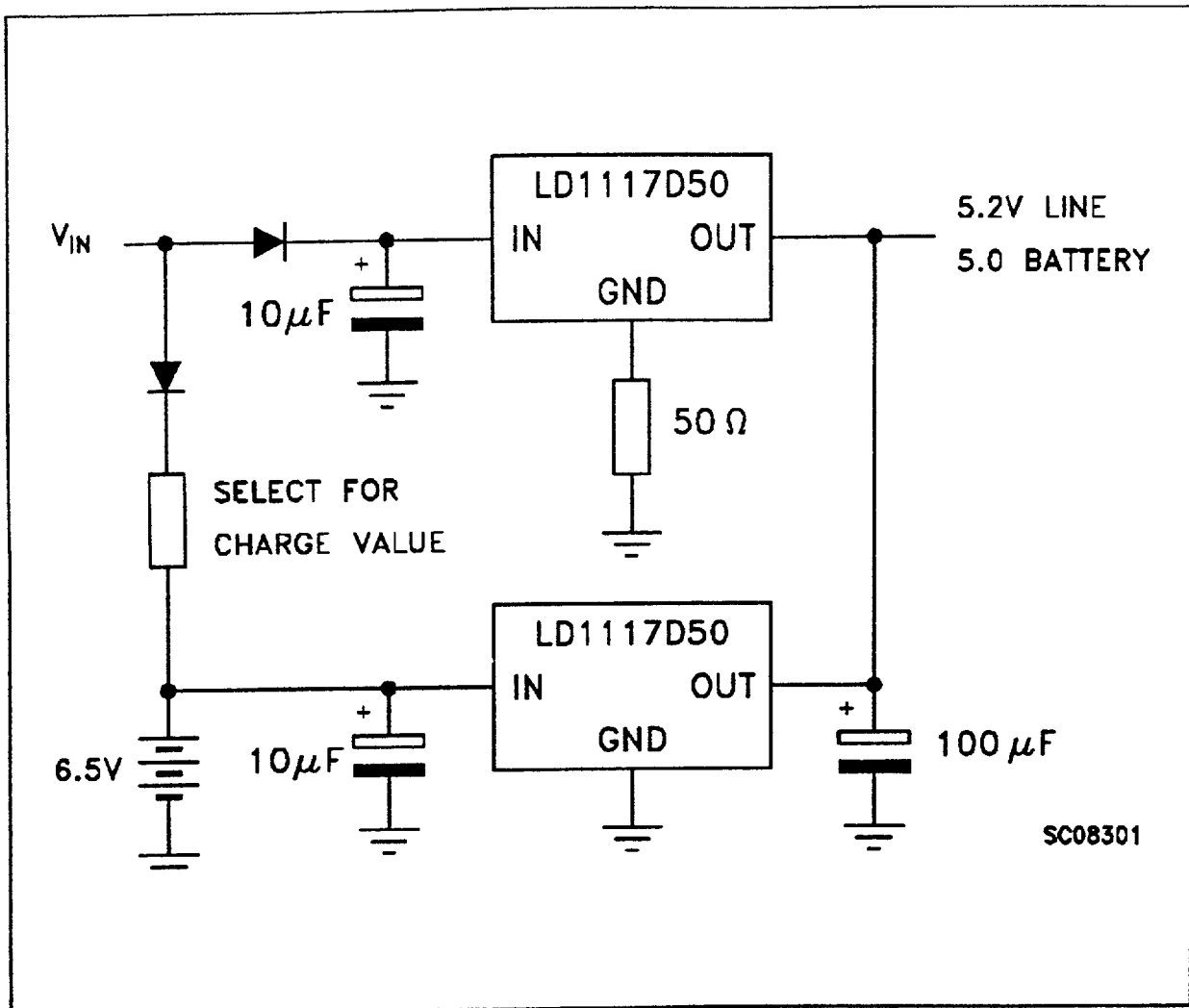
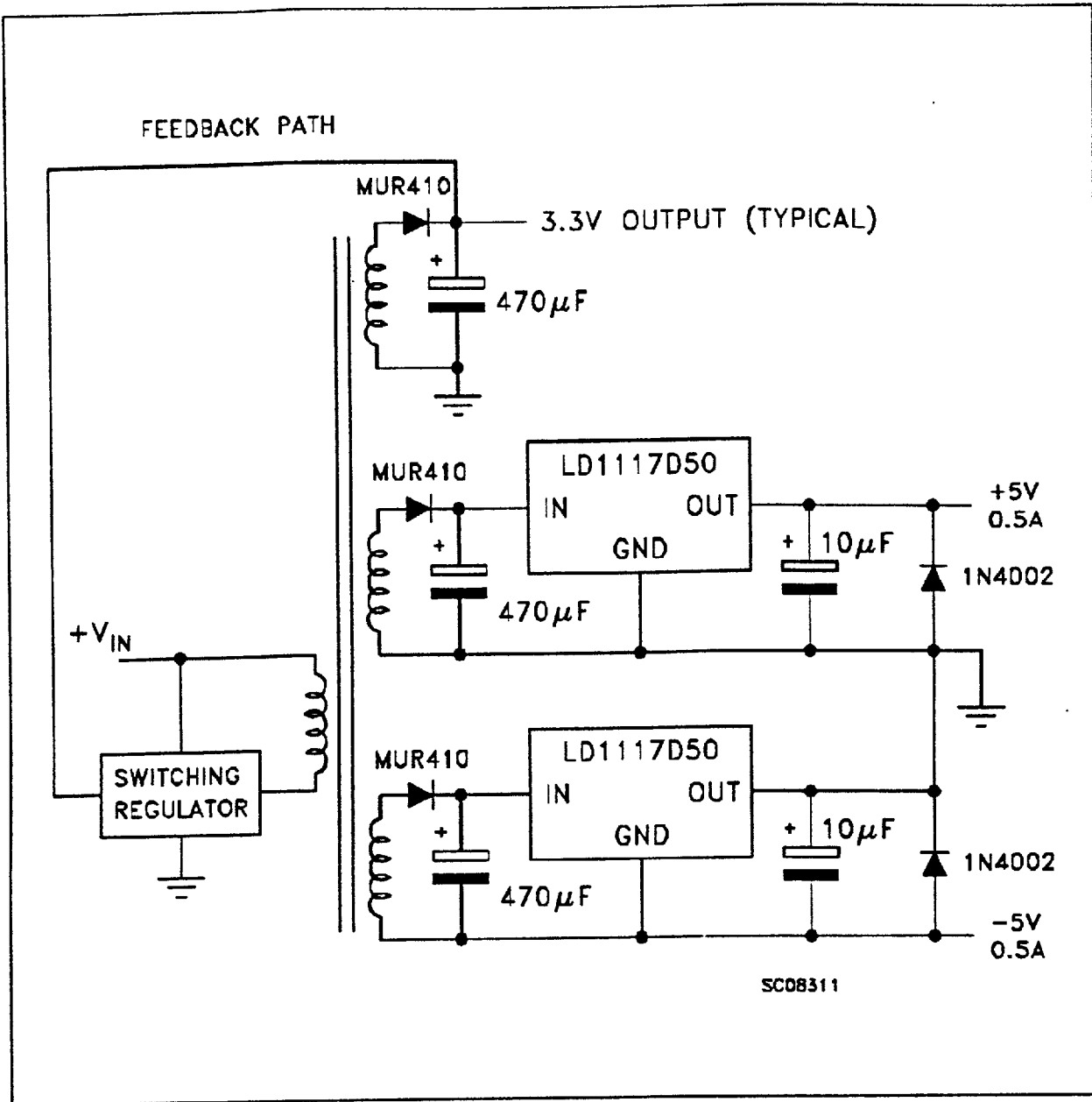

FIGURE 5: Battery Backed-up Regulated Supply



TYPICAL APPLICATIONS (continued):  
**FIGURE 6: Post-Regulated Dual Supply**



TO39 MECHANICAL DATA

DIM.	mm			mils		
	MIN.	TYP.	MAX.	MIN.	TYP.	MAX.
a	2.27	2.3	2.33	89.4	90.6	91.7
b	4.57	4.6	4.63	179.9	181.1	182.3
c	0.2	0.4	0.6	7.9	15.7	23.6
d	0.63	0.65	0.67	24.8	25.6	26.4
e1	1.5	1.6	1.7	59.1	63	66.9
e4			0.32			12.6
f	2.9	3	3.1	114.2	118.1	122.1
g	0.67	0.7	0.73	26.4	27.6	28.7
l1	6.7	7	7.3	263.8	275.6	287.4
l2	3.5	3.5	3.7	137.8	137.8	145.7
L	6.3	6.5	6.7	248	255.9	263.8

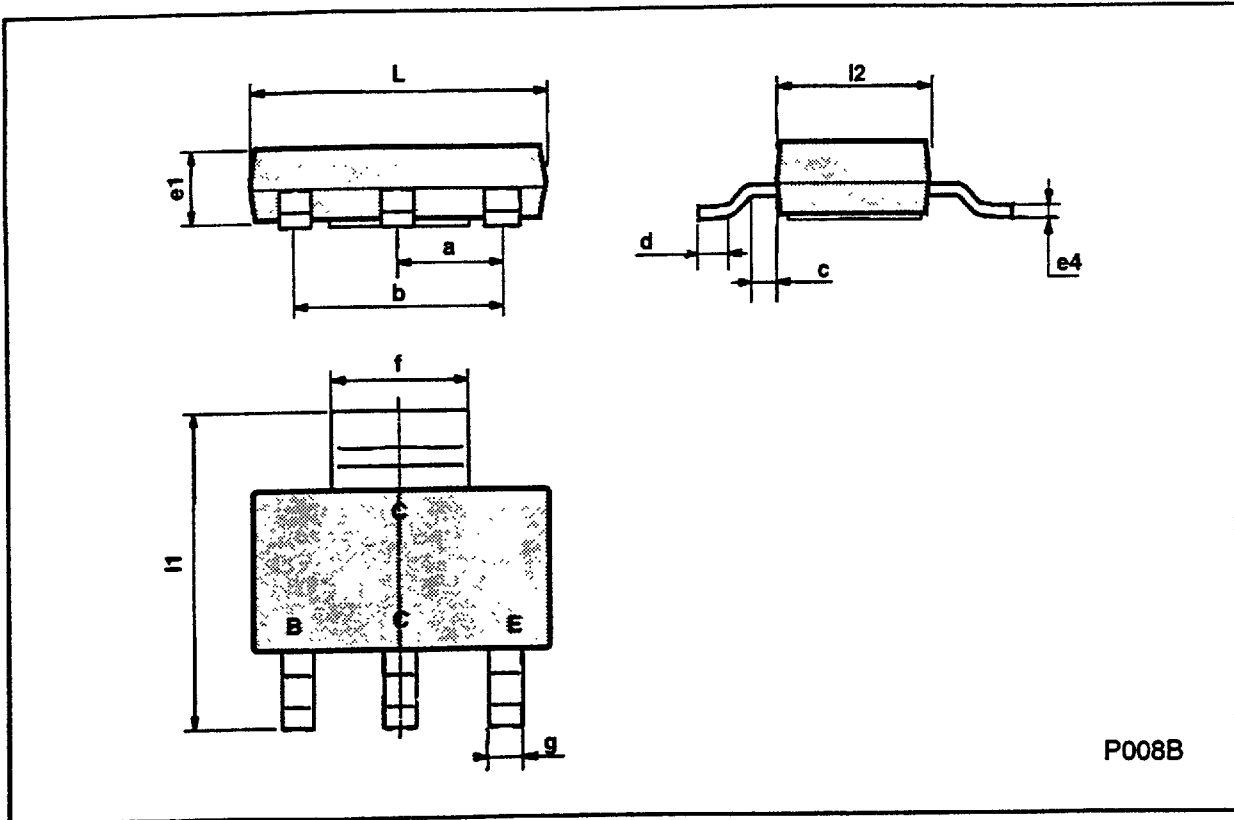

P008B

## TO-252 (DPAK) MECHANICAL DATA

DIM.	mm			inch		
	MIN.	TYP.	MAX.	MIN.	TYP.	MAX.
A	2.2		2.4	0.086		0.094
A1	0.9		1.1	0.035		0.043
A2	0.03		0.23	0.001		0.009
B	0.64		0.9	0.025		0.035
B2	5.2		5.4	0.204		0.212
C	0.45		0.6	0.017		0.023
C2	0.48		0.6	0.019		0.023
D	6		6.2	0.236		0.244
E	6.4		6.6	0.252		0.260
G	4.4		4.6	0.173		0.181
H	9.35		10.1	0.368		0.397
L2		0.8			0.031	
L4	0.6		1	0.023		0.039

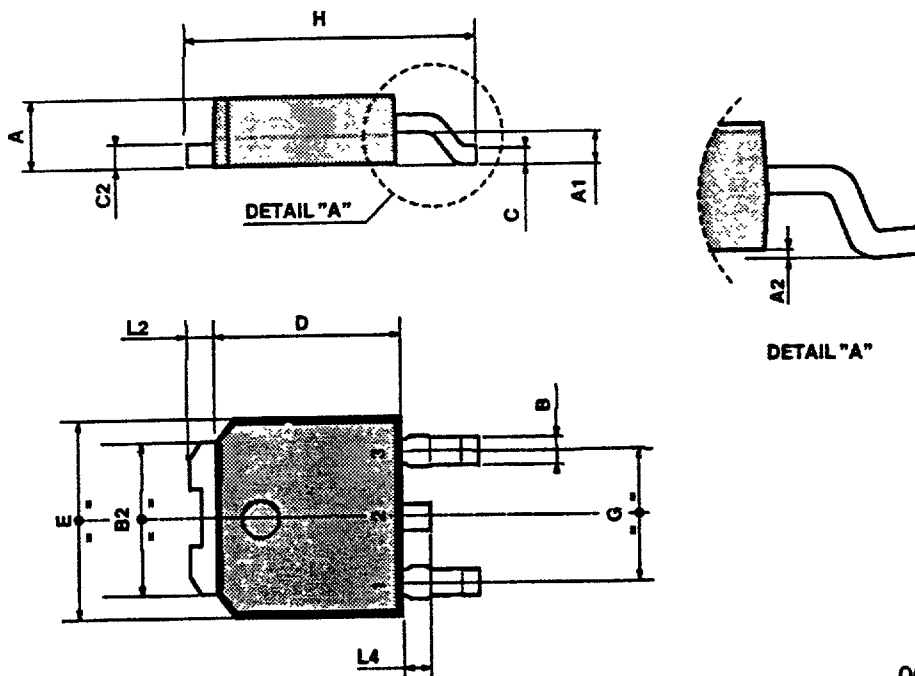

**SO8 MECHANICAL DATA**

DIM.	mm			inch		
	MIN.	TYP.	MAX.	MIN.	TYP.	MAX.
A			1.75			0.068
a1	0.1		0.25	0.003		0.009
a2			1.65			0.064
a3	0.65		0.85	0.025		0.033
b	0.35		0.48	0.013		0.018
b1	0.19		0.25	0.007		0.010
C	0.25		0.5	0.010		0.019
c1	45° (typ.)					
D	4.8		5.0	0.188		0.196
E	5.8		6.2	0.228		0.244
e		1.27			0.050	
e3		3.81			0.150	
F	3.8		4.0	0.14		0.157
L	0.4		1.27	0.015		0.050
M			0.6			0.023
S	8° (max.)					

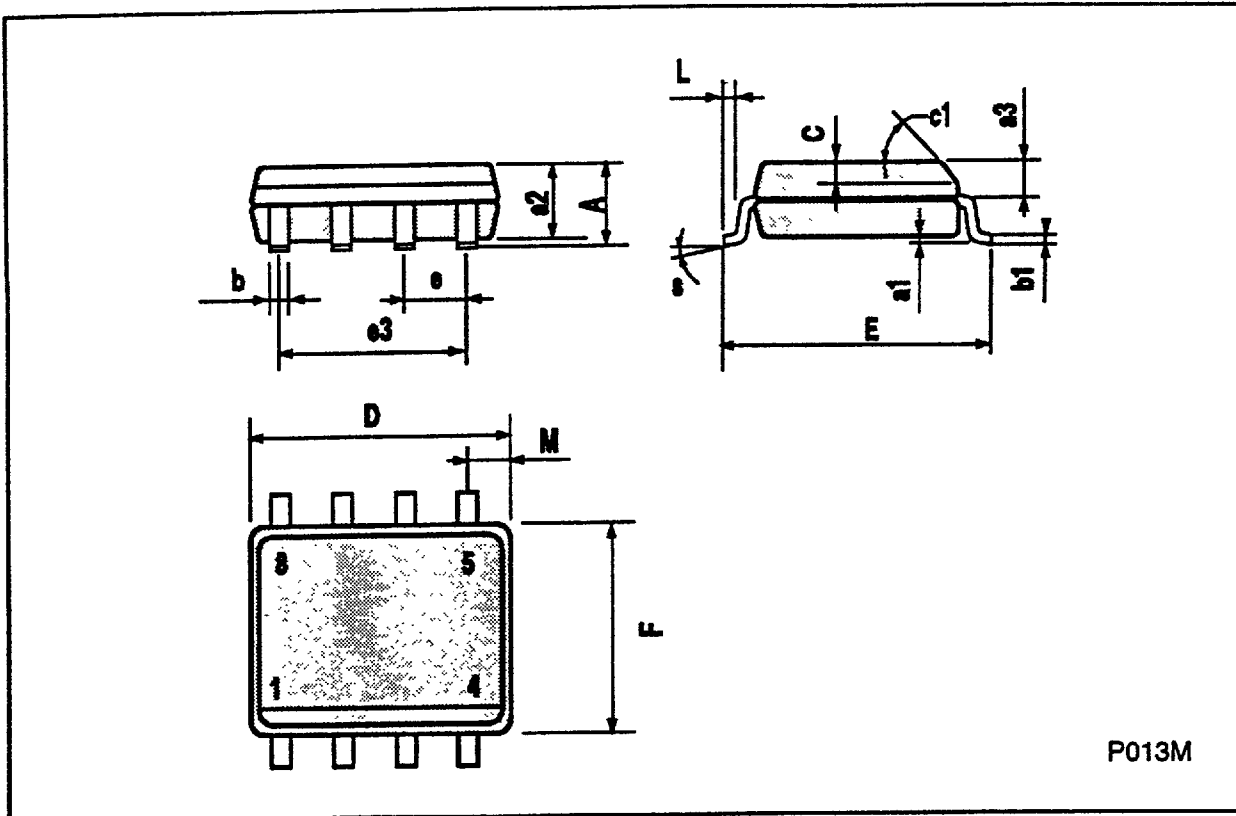

P013M

## TO-220 MECHANICAL DATA

DIM.	mm			inch		
	MIN.	TYP.	MAX.	MIN.	TYP.	MAX.
A			4.8			0.189
C			1.37			0.054
D	2.4		2.8	0.094		0.110
D1	1.2		1.35	0.047		0.053
E	0.35		0.55	0.014		0.022
F	0.8		1.05	0.031		0.041
F2	1.15		1.4	0.045		0.055
G	4.95	5.08	5.21	0.195	0.200	0.205
H2			10.4			0.409
H3	10.05		10.4	0.396		0.409
L2		16.2			0.638	
L3	26.3	26.7	27.1	1.035	1.051	1.067
L5	2.6		3	0.102		0.118
L6	15.1		15.8	0.594		0.622
L7	6		6.6	0.236		0.260
Dia.	3.65		3.85	0.144		0.152

