

Document No.	
ECN No.	
Date of Issue	August 13, 1990
Status	Preliminary Specification
ACL Products	

AC11657: Objective Specification

ACT11657: Preliminary Specification

Octal transceiver with 8-bit parity checker/generator

FEATURES

- 3-State outputs
- Combines '245 and '280 functions in one package
- Output capability: ± 24 mA
- CMOS (AC) and TTL (ACT) voltage level inputs
- 50Ω incident wave switching
- Center-pin V_{CC} and ground configuration to minimize high-speed switching noise
- I_{CC} category: MSI

DESCRIPTION

The 74AC/ACT11657 high-performance CMOS devices combine very high speed and high output drive comparable to the most advanced TTL families.

The 74AC/ACT11657 device is an octal transceiver featuring non-inverting buffers and an 8-bit parity generator/checker, and is intended for bus-oriented applications.

The Transmit/Receive (T/\bar{R}) input determines the direction of the data flow through the bidirectional transceivers. Transmit (active-High) enables data

(continued)

PIN CONFIGURATION

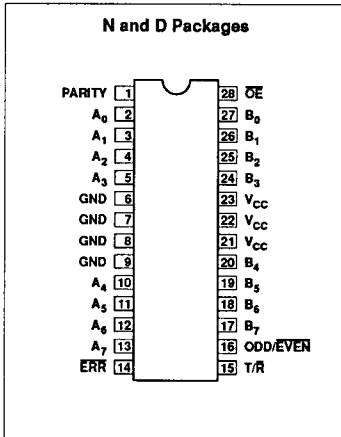

QUICK REFERENCE DATA

SYMBOL	PARAMETER	CONDITIONS		TYPICAL		UNIT
		$T_{amb} = 25^\circ\text{C}; \text{GND} = 0\text{V}; V_{CC} = 5.0\text{V}$		AC	ACT	
t_{PLH}/t_{PHL}	Propagation delay A_n to B_n	$C_L = 50\text{pF}$			5.3	ns
C_{PD}	Power dissipation capacitance per transceiver ¹	$f = 1\text{MHz}; C_L = 50\text{pF}$	Enabled		95	pF
			Disabled		21	
C_{IN}	Input capacitance	$V_I = 0\text{V}$ or V_{CC}		4.5	4.5	pF
C_{OUT}	Output capacitance	$V_O = 0\text{V}$ or V_{CC} ; Disabled		10	10	pF
C_{IO}	I/O capacitance	$V_{IO} = 0\text{V}$ or V_{CC} ; Disabled		12	12	pF
I_{LATCH}	Latch-up current	Per Jeduc JC40.2 Standard 17		500	500	mA

Note:

1. C_{PD} is used to determine the dynamic power dissipation (P_D in μW):

$$P_D = C_{PD} \times V_{CC}^2 \times f_i + \sum (C_L \times V_{CC}^2 \times f_o) \text{ where:}$$

f_i = input frequency in MHz, C_L = output load capacitance in pF,

f_o = output frequency in MHz, V_{CC} = supply voltage in V,

$\sum (C_L \times V_{CC}^2 \times f_o)$ = sum of outputs

ORDERING INFORMATION

PACKAGES	TEMPERATURE RANGE	ORDER CODE
28-pin plastic DIP (300mil-wide)	-40°C to +85°C	74AC11657N 74ACT11657N
28-pin plastic SOL (300mil-wide)	-40°C to +85°C	74AC11657D 74ACT11657D

LOGIC SYMBOL

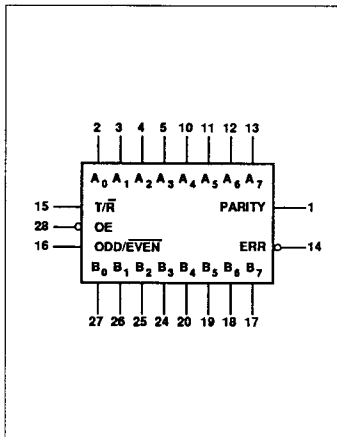

LOGIC SYMBOL (IEEE/IEC)

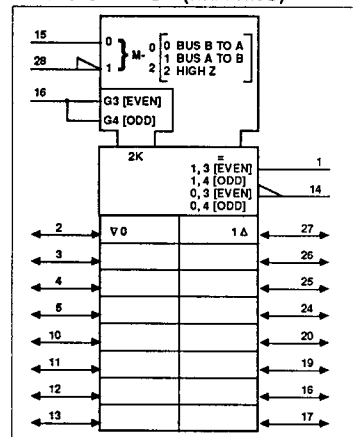

Octal transceiver with 8-bit parity checker/generator

74AC/ACT11657

from A ports to B ports; Receive (active-Low) enables data from B ports to A ports.

The Output Enable (\overline{OE}) input disables both the A and B ports by placing them in a high impedance condition when the \overline{OE} input is High. The parity select (ODD/EVEN) input gives the user the option of odd or even parity systems. The parity (PARITY) pin is an output from the generator/checker when transmitting from port A to B (T/\overline{R} = High) and an input when receiving from port B to A (T/\overline{R} = Low). When transmitting (T/\overline{R}

\overline{R} = High) the parity select (ODD/EVEN) input is set, then the A port data is polled to determine the number of High bits. The parity (PARITY) output then goes to the logic state determined by the parity select (ODD/EVEN) setting and by the number of High bits on port A. For example, if the parity select (ODD/EVEN) is set Low (even parity), and the number of High bits on port A is odd, then the parity (PARITY) output will be High, transmitting even parity. If the number of High bits on port A is even, then the parity (PARITY) output will be Low, keeping even parity. When

in receive mode (T/\overline{R} = Low) the B port is polled to determine the number of High bits.

If parity select (ODD/EVEN) is Low (even parity) and the number of Highs on port B is:

(1) odd and the parity (PARITY) input is High, then \overline{ERR} will be High, signifying no error.

(2) even and the parity (PARITY) input is High, then \overline{ERR} will be asserted Low, indicating an error.

PIN DESCRIPTION

PIN NUMBER	SYMBOL	NAME AND FUNCTION
15	T/\overline{R}	Transmit/receive input
16	ODD/EVEN	Parity select input
28	\overline{OE}	Output enable input (active-Low)
2, 3, 4, 5, 10, 11, 12, 13	$A_0 - A_7$	A ports 3-State inputs/output
27, 26, 25, 24, 20, 19, 18, 17	$B_0 - B_7$	B ports 3-State inputs/output
1	PARITY	Parity input/output
14	\overline{ERR}	Error output
6, 7, 8, 9	GND	Ground (0V)
21, 22, 23	V_{CC}	Positive supply voltage

FUNCTION TABLE

NUMBER OF INPUTS THAT ARE HIGH	INPUTS			INPUT/OUTPUT	OUTPUTS	
	\overline{OE}	T/\overline{R}	ODD/EVEN	PARITY	\overline{ERR}	OUTPUTS MODE
0, 2, 4, 6, 8	L	H	H	H	Z	Transmit
	L	H	L	L	Z	Transmit
	L	L	H	H	H	Receive
	L	L	H	L	L	Receive
	L	L	L	H	L	Receive
1, 3, 5, 7	L	H	H	L	Z	Transmit
	L	H	L	H	Z	Transmit
	L	L	H	H	L	Receive
	L	L	H	L	H	Receive
	L	L	L	H	H	Receive
Don't care	H	X	X	Z	Z	Z

H = High voltage level
 L = Low voltage level
 X = Don't care
 Z = High-impedance state

Octal transceiver with 8-bit parity checker/generator

74AC/ACT11657

LOGIC DIAGRAM

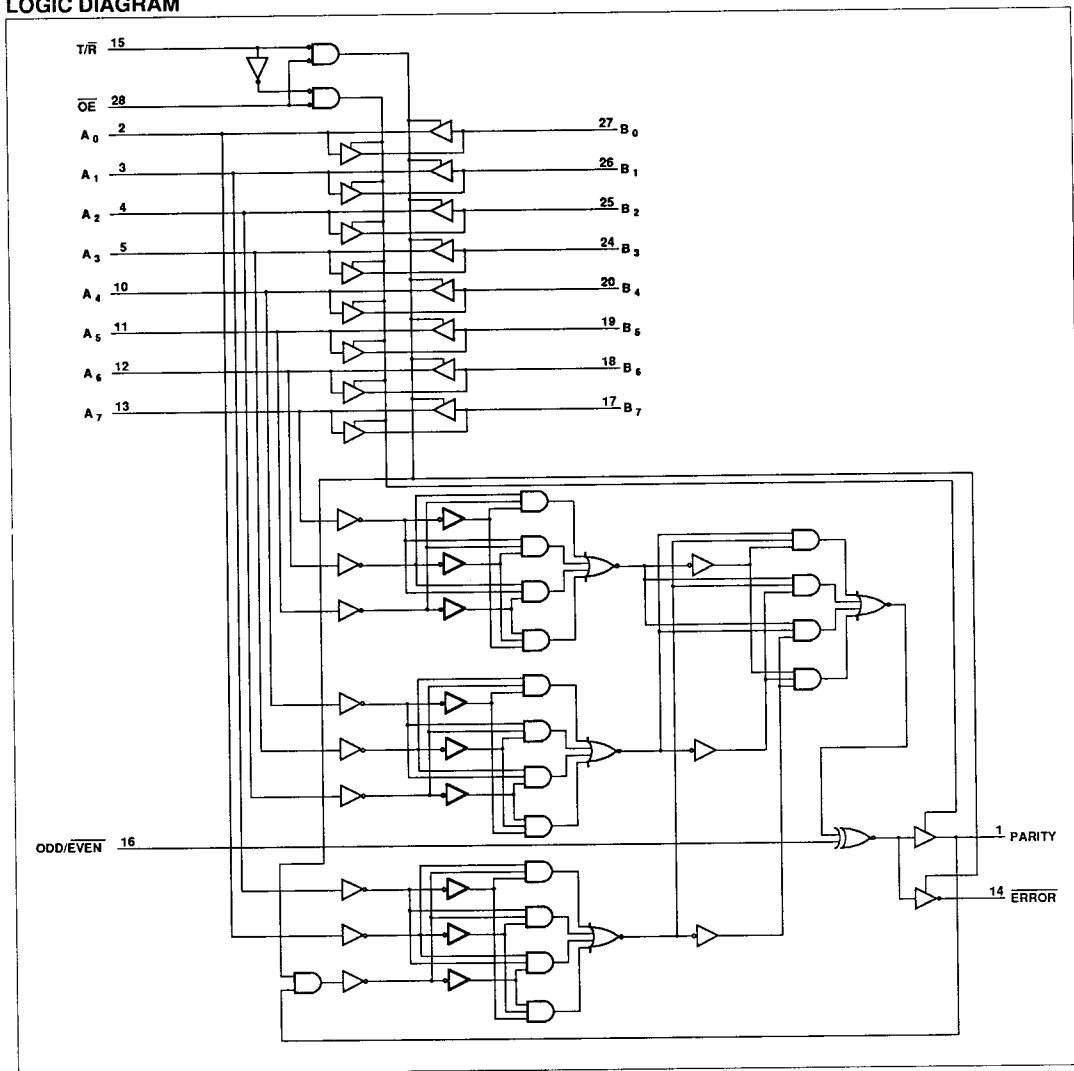

Octal transceiver with 8-bit parity checker/generator

74AC/ACT11657

RECOMMENDED OPERATING CONDITIONS

SYMBOL	PARAMETER	74AC11657			74ACT11657			UNIT
		Min	Nom	Max	Min	Nom	Max	
V_{CC}	DC supply voltage	3.0 ¹	5.0	5.5	4.5	5.0	5.5	V
V_I	Input voltage	0		V_{CC}	0		V_{CC}	V
V_O	Output voltage	0		V_{CC}	0		V_{CC}	V
$\Delta V/\Delta t$	Input transition rise or fall rate	\overline{OE} only	0	10	0		10	ns/V
		All other inputs	0	5	0		5	
T_{amb}	Operating free-air temperature range	-40		+85	-40		+85	°C

NOTE:

1. No electrical or switching characteristics are specified at $V_{CC} < 3V$. Operation between 2V and 3V is not recommended, but within that range, a device output will maintain a previously established logic state.

ABSOLUTE MAXIMUM RATINGS¹

SYMBOL	PARAMETER	TEST CONDITIONS	RATING	UNIT
V_{CC}	DC supply voltage		-0.5 TO +7.0	V
I_{IK} or V_I	DC input diode current ²	$V_I < 0$	-20	mA
		$V_I > V_{CC}$	20	
	DC input voltage		-0.5 to $V_{CC} + 0.5$	V
I_{OK} or V_O	DC output diode current ²	$V_O < 0$	-50	mA
		$V_O > V_{CC}$	50	
	DC output voltage		-0.5 to $V_{CC} + 0.5$	V
I_O	DC output source or sink current per output pin	$V_O = 0$ to V_{CC}	±50	mA
I_{CC} or I_{GND}	DC V_{CC} current		±250	mA
	DC ground current		±250	
T_{STG}	Storage temperature		-65 to 150	°C
P_{TOT}	Power dissipation per package	Above 70°C; derate linearly by 8mW/K	500	mW
	Power dissipation per package Plastic surface mount (SO)	Above 70°C; derate linearly by 8mW/K	400	mW

NOTES:

- Stresses beyond those listed may cause permanent damage to the device. These are stress ratings only and functional operation of the device at these or any other conditions beyond those indicated under "recommended operating conditions" is not implied. Exposure to absolute-maximum-rated conditions for extended periods may affect device reliability.
- The input and output voltage ratings may be exceeded if the input and output current ratings are observed.

Octal transceiver with 8-bit parity checker/generator

74AC/ACT11657

DC ELECTRICAL CHARACTERISTICS

SYMBOL	PARAMETER	TEST CONDITIONS	V _{CC} V	74AC11657				74ACT11657				UNIT	
				T _{amb} = +25°C		T _{amb} = -40°C to +85°C		T _{amb} = +25°C		T _{amb} = -40°C to +85°C			
				Min	Max	Min	Max	Min	Max	Min	Max		
V _{IH}	High-level input voltage		3.0	2.10		2.10						V	
			4.5	3.15		3.15		2.0		2.0			
			5.5	3.85		3.85		2.0		2.0			
V _{IL}	Low-level input voltage		3.0		0.90		0.90					V	
			4.5		1.35		1.35		0.8		0.8		
			5.5		1.65		1.65		0.8		0.8		
V _{OH}	High-level output voltage	V _I = V _{IL} or V _{IH}	I _{OH} = -50μA	3.0	2.9		2.9					V	
				4.5	4.4		4.4		4.4		4.4		
				5.5	5.4		5.4		5.4		5.4		
			I _{OH} = -4mA	3.0	2.58		2.48						
				4.5	3.94		3.8		3.94		3.8		
				5.5	4.94		4.8		4.94		4.8		
I _{OH} = -75mA ¹	5.5			3.85				3.85					
V _{OL}	Low-level output voltage	V _I = V _{IL} or V _{IH}	I _{OL} = 50μA	3.0		0.1		0.1				V	
				4.5		0.1		0.1		0.1			0.1
				5.5		0.1		0.1		0.1			0.1
			I _{OL} = 12mA	3.0		0.36		0.44					
				4.5		0.36		0.44		0.36			0.44
				5.5		0.36		0.44		0.36			0.44
I _{OL} = 24mA	5.5				1.65				1.65				
I _I	Input leakage current	V _I = V _{CC} or GND	5.5		±0.1		±1.0		±0.1		±1.0	μA	
I _{oz}	3-State output off-state current	V _I = V _{IL} or V _{IH} , V _O = V _{CC} or GND	5.5		±0.5		5.0		±0.5		5.0	μA	
I _{CC}	Quiescent supply current	V _I = V _{CC} or GND, I _O = 0mA	5.5		8.0		80		8.0		80	μA	
ΔI _{CC}	Supply current, TTL inputs High ²	One input at 3.4V, other inputs at V _{CC} or GND	5.5						0.9		1.0	mA	

NOTES:

1. Not more than one output should be tested at a time, and the duration of the test should not exceed 10ms.
2. This is the increase in supply current for each input that is at one of the specified TTL voltage levels rather than 0V or V_{CC}.

Octal transceiver with 8-bit parity checker/generator

74AC/ACT11657

AC ELECTRICAL CHARACTERISTICS AT 3.3V ±0.3V

SYMBOL	PARAMETER	WAVEFORM	74AC11657					UNIT
			T _{amb} = +25°C			T _{amb} = -40°C to +85°C		
			Min	Typ	Max	Min	Max	
t _{PLH} t _{PHL}	Propagation delay, A _n to B _n or B _n to A _n	1						ns
t _{PLH} t _{PHL}	Propagation delay, A _n to PARITY	1						ns
t _{PLH} t _{PHL}	Propagation delay, ODDEVEN to PARITY, ERROR	1						ns
t _{PLH} t _{PHL}	Propagation delay, B _n to ERROR	1						ns
t _{PLH} t _{PHL}	Propagation delay, PARITY to ERROR	1						ns
t _{PZH} t _{PZL}	Output enable time to High and Low level	2						ns
t _{PHZ} t _{PLZ}	Output disable time from High and Low level	2						ns

AC ELECTRICAL CHARACTERISTICS AT 5.0V ±0.5V

SYMBOL	PARAMETER	WAVEFORM	74AC11657					UNIT
			T _{amb} = +25°C			T _{amb} = -40°C to +85°C		
			Min	Typ	Max	Min	Max	
t _{PLH} t _{PHL}	Propagation delay, A _n to B _n or B _n to A _n	1						ns
t _{PLH} t _{PHL}	Propagation delay, A _n to PARITY	1						ns
t _{PLH} t _{PHL}	Propagation delay, ODDEVEN to PARITY, ERROR	1						ns
t _{PLH} t _{PHL}	Propagation delay, B _n to ERROR	1						ns
t _{PLH} t _{PHL}	Propagation delay, PARITY to ERROR	1						ns
t _{PZH} t _{PZL}	Output enable time to High and Low level	2						ns
t _{PHZ} t _{PLZ}	Output disable time from High and Low level	2						ns

Octal transceiver with 8-bit parity checker/generator

74AC/ACT11657

AC ELECTRICAL CHARACTERISTICS AT 5.0V ±0.5V

SYMBOL	PARAMETER	WAVEFORM	74ACT11657					UNIT
			T _{amb} = +25°C			T _{amb} = -40°C to +85°C		
			Min	Typ	Max	Min	Max	
t _{PLH} t _{PHL}	Propagation delay, A _n to B _n or B _n to A _n	1	3.2 2.2	5.5 5.1	6.9 7.2	3.2 2.2	7.6 7.8	ns
t _{PLH} t _{PHL}	Propagation delay, A _n to PARITY	1	3.6 4.0	7.5 8.1	10.3 10.7	3.6 4.0	11.5 12.0	ns
t _{PLH} t _{PHL}	Propagation delay, ODD/EVEN to PARITY, ERROR	1	2.8 3.1	6.0 6.4	7.8 8.3	2.8 3.1	8.7 9.1	ns
t _{PLH} t _{PHL}	Propagation delay, B _n to ERROR	1	4.6 4.9	12.4 12.8	16.9 17.7	4.6 4.9	19.4 20.2	ns
t _{PLH} t _{PHL}	Propagation delay, PARITY to ERROR	1	4.1 3.9	7.7 7.7	10.0 10.4	4.1 3.9	11.1 11.4	ns
t _{PZH} t _{PZL}	Output enable time to High and Low level	2	3.2 3.9	6.2 7.5	9.8 10.5	3.2 3.9	10.5 11.6	ns
t _{PHZ} t _{PLZ}	Output disable time from High and Low level	2	4.5 4.8	7.5 7.4	10.1 9.3	4.5 4.8	10.9 10.0	ns

AC WAVEFORMS

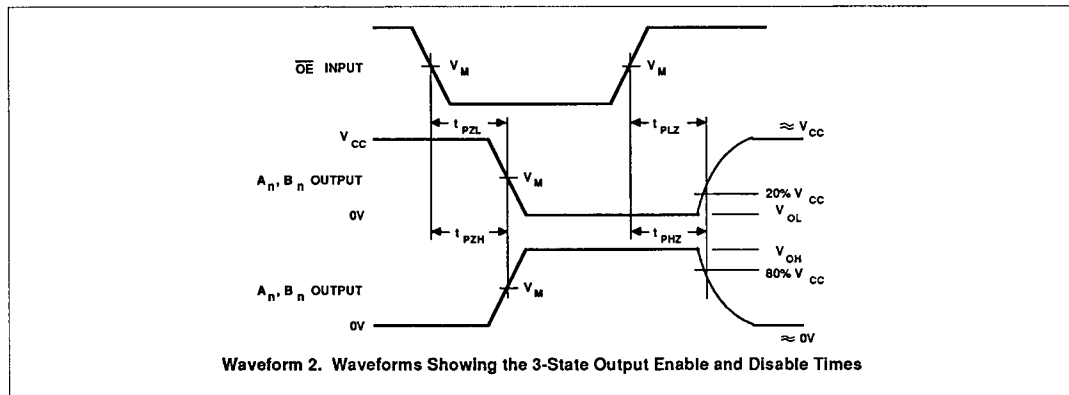
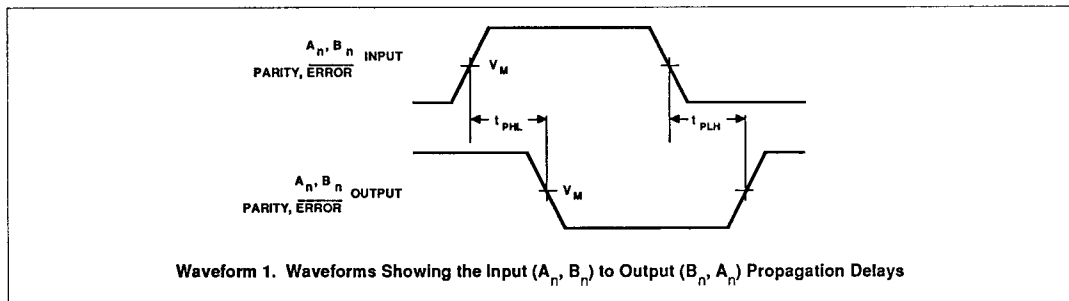

Octal transceiver with 8-bit parity checker/generator

74AC/ACT11657

WAVEFORM CONDITIONS

	INPUTS	OUTPUTS
AC	$V_{IN} = \text{GND to } V_{CC},$ $V_M = 50\% V_{CC}$	$V_{OUT} = V_{OL} \text{ to } V_{OH}$ $V_M = 50\% V_{CC}$
ACT	$V_{IN} = \text{GND to } 3.0V,$ $V_M = 1.5V$	

TEST CIRCUIT

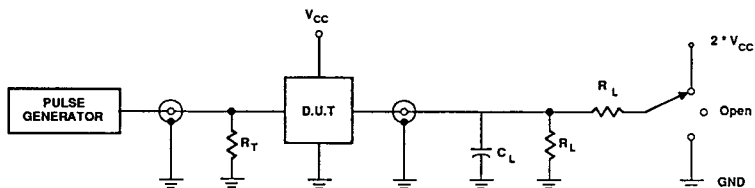

Test Circuit

TEST	S1
t_{PLH}/t_{PHL}	Open
t_{PLZ}/t_{PZL}	$2 \cdot V_{CC}$
t_{PHZ}/t_{PZH}	GND

SWITCH POSITION

DEFINITIONS

C_L = Load capacitance, 50pF; includes jig and probe capacitance
 R_L = Load resistor, 500Ω
 R_T = Termination resistance should be equal to Z_{OUT} of pulse generators
 Input pulses: PRR ≤ 10MHz
 $t_r = t_f = 3ns$