

T-46-07-11



54ACT/74ACT563

Octal Latch with TRI-STATE® Outputs

General Description

The 'ACT563 is a high-speed octal latch with buffered common Latch Enable (LE) and buffered common Output Enable (OE) inputs.

The 'ACT563 device is functionally identical to the 'ACT573, but with inverted outputs.

Features

- I_{CC} and I_{OZ} reduced by 50%
- Inputs and outputs on opposite sides of package allow easy interface with microprocessors
- Useful as input or output port for microprocessors
- Functionally identical to 'ACT573 but with inverted outputs
- Outputs source/sink 24 mA
- 'ACT563 has TTL-compatible inputs
- Standard Military Drawing (SMD)
—'ACT563: 5962-89556

Ordering Code: See Section 8

Logic Symbols

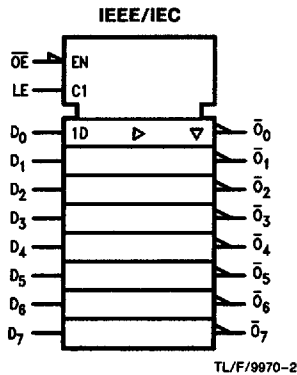
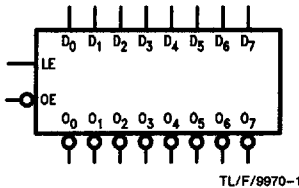

Connection Diagrams

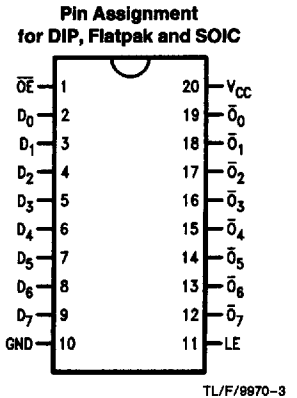

Pin Names	Description
D ₀ -D ₇	Data Inputs
LE	Latch Enable Input
OE	TRI-STATE Output Enable Input
O ₀ -O ₇	TRI-STATE Latch Outputs

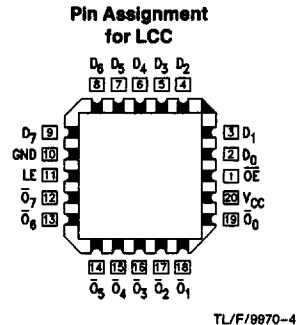

Functional Description

The 7ACT563 contains eight D-type latches with TRI-STATE complementary outputs. When the Latch Enable (LE) input is HIGH, data on the D_n inputs enters the latches. In this condition the latches are transparent, i.e., a latch output will change state each time its D input changes. When LE is LOW the latches store the information that was present on the D inputs a setup time preceding the HIGH-to-LOW transition of LE. The TRI-STATE buffers are controlled by the Output Enable (\overline{OE}) input. When \overline{OE} is LOW, the buffers are in the bi-state mode. When \overline{OE} is HIGH the buffers are in the high impedance mode but that does not interfere with entering new data into the latches.

Function Table

Inputs			Internal	Outputs	Function
\overline{OE}	LE	D	Q	O	
H	X	X	X	Z	High-Z
H	H	L	H	Z	High-Z
H	H	H	L	Z	High-Z
H	L	X	NC	Z	Latched
L	H	L	H	H	Transparent
L	H	H	L	L	Transparent
L	L	X	NC	NC	Latched

H = HIGH Voltage Level
 L = LOW Voltage Level
 X = Immaterial
 Z = High Impedance
 NC = No Change

Logic Diagram

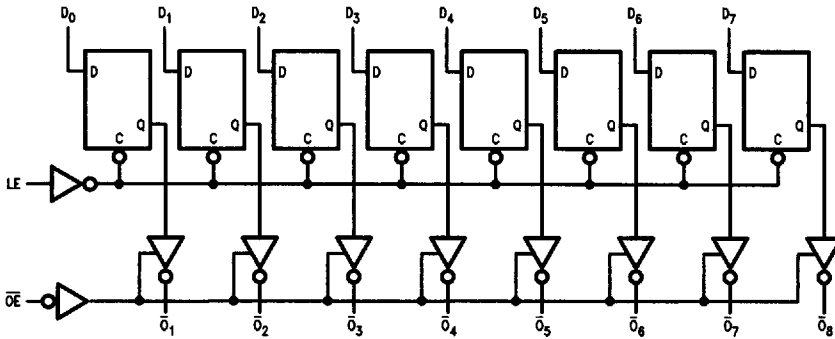

TL/F/9970-5

Please note that this diagram is provided only for the understanding of logic operations and should not be used to estimate propagation delays

Absolute Maximum Ratings (Note 1)

If Military/Aerospace specified devices are required, please contact the National Semiconductor Sales Office/Distributors for availability and specifications.

Supply Voltage (V_{CC})	-0.5V to +7.0V
DC Input Diode Current (I_{IK})	
$V_I = -0.5V$	-20 mA
$V_I = V_{CC} + 0.5V$	+20 mA
DC Input Voltage (V_I)	-0.5V to $V_{CC} + 0.5V$
DC Output Diode Current (I_{OK})	
$V_O = -0.5V$	-20 mA
$V_O = V_{CC} + 0.5V$	+20 mA
DC Output Voltage (V_O)	-0.5V to $V_{CC} + 0.5V$
DC Output Source or Sink Current (I_O)	±50 mA
DC V_{CC} or Ground Current per Output Pin (I_{CC} or I_{GND})	±50 mA
Storage Temperature (T_{STG})	-65°C to +150°C
Junction Temperature (T_J)	
CDIP	175°C
PDIP	140°C

Note 1: Absolute maximum ratings are those values beyond which damage to the device may occur. The databook specifications should be met, without exception, to ensure that the system design is reliable over its power supply, temperature, and output/input loading variables. National does not recommend operation of FACT™ circuits outside databook specifications.

Recommended Operating Conditions

Supply Voltage (V_{CC})	4.5V to 5.5V
'ACT	
Input Voltage (V_I)	0V to V_{CC}
Output Voltage (V_O)	0V to V_{CC}
Operating Temperature (T_A)	
74ACT	-40°C to +85°C
54ACT	-55°C to +125°C
Minimum Input Edge Rate ($\Delta V/\Delta t$)	
'ACT Devices	
V_{IN} from 0.8V to 2.0V	
V_{CC} @ 4.5V, 5.5V	125 mV/ns

DC Characteristics for 'ACT Family Devices

Symbol	Parameter	V_{CC} (V)	74ACT		54ACT	74ACT	Units	Conditions
			$T_A = +25^\circ C$		$T_A = -55^\circ C$ to $+125^\circ C$	$T_A = -40^\circ C$ to $+85^\circ C$		
			Typ	Guaranteed Limits				
V_{IH}	Minimum High Level Input Voltage	4.5	1.5	2.0	2.0	2.0	V	$V_{OUT} = 0.1V$ or $V_{CC} - 0.1V$
		5.5	1.5	2.0	2.0	2.0		
V_{IL}	Maximum Low Level Input Voltage	4.5	1.5	0.8	0.8	0.8	V	$V_{OUT} = 0.1V$ or $V_{CC} - 0.1V$
		5.5	1.5	0.8	0.8	0.8		
V_{OH}	Minimum High Level Output Voltage	4.5	4.49	4.4	4.4	4.4	V	$I_{OUT} = -50 \mu A$
		5.5	5.49	5.4	5.4	5.4		
		4.5		3.86	3.70	3.76	V	* $V_{IN} = V_{IL}$ or V_{IH} $I_{OH} = -24 mA$
		5.5		4.86	4.70	4.76		
V_{OL}	Maximum Low Level Output Voltage	4.5	0.001	0.1	0.1	0.1	V	$I_{OUT} = 50 \mu A$
		5.5	0.001	0.1	0.1	0.1		
		4.5		0.36	0.50	0.44	V	* $V_{IN} = V_{IL}$ or V_{IH} $I_{OL} = 24 mA$
		5.5		0.36	0.50	0.44		
I_{IN}	Maximum Input Leakage Current	5.5		±0.1	±1.0	±1.0	μA	$V_I = V_{CC}, GND$
I_{OZ}	Maximum TRI-STATE® Current	5.5		±0.25	±5.0	±2.5	μA	$V_I = V_{IL}, V_{IH}$ $V_O = V_{CC}, GND$
I_{OCT}	Maximum $I_{CC}/Input$	5.5	0.6		1.6	1.5	mA	$V_I = V_{CC} - 2.1V$

*All outputs loaded; thresholds on input associated with output under test.

DC Characteristics for 'ACT Family Devices (Continued)

Symbol	Parameter	V _{CC} (V)	74ACT		54ACT		74ACT		Units	Conditions
			T _A = +25°C		T _A = -55°C to +125°C		T _A = -40°C to +85°C			
			Typ	Guaranteed Limits						
I _{OLD}	†Minimum Dynamic Output Current	5.5			50		75		mA	V _{OLD} = 1.65V Max
I _{OHD}		5.5			-50		-75		mA	V _{OHD} = 3.85V Min
I _{CC}	Maximum Quiescent Supply Current	5.5		4.0	80.0		40.0		µA	V _{IN} = V _{CC} or GND

†Maximum test duration 2.0 ms, one output loaded at a time.

Note: I_{CC} for 54ACT @ 25°C is identical to 74ACT @ 25°C.

AC Electrical Characteristics: See Section 2 for Waveforms

Symbol	Parameter	V _{CC} * (V)	74ACT			54ACT		74ACT		Units	Fig. No.
			T _A = +25°C C _L = 50 pF			T _A = -55°C to +125°C C _L = 50 pF		T _A = -40°C to +85°C C _L = 50 pF			
			Min	Typ	Max	Min	Max	Min	Max		
t _{PLH}	Propagation Delay D _n to \bar{O}_n	5.0	3.0	7.0	11.5	1.0	14.5	2.5	12.5	ns	2-3,4
t _{PHL}	Propagation Delay D _n to \bar{O}_n	5.0	3.0	6.0	10.0	1.0	12.0	2.5	11.0	ns	2-3,4
t _{PLH}	Propagation Delay LE to \bar{O}_n	5.0	3.0	6.5	10.5	1.0	12.5	2.5	11.5	ns	2-3,4
t _{PHL}	Propagation Delay LE to \bar{O}_n	5.0	2.5	5.5	9.5	1.0	11.5	2.0	10.5	ns	2-3,4
t _{pZH}	Output Enable Time	5.0	2.5	5.5	9.0	1.0	11.5	2.0	10.0	ns	2-5
t _{pZL}	Output Enable Time	5.0	2.0	5.5	8.5	1.0	11.0	2.0	9.5	ns	2-6
t _{pHZ}	Output Disable Time	5.0	3.5	6.5	10.5	1.0	12.0	2.5	11.5	ns	2-5
t _{pLZ}	Output Disable Time	5.0	2.0	4.5	8.0	1.0	9.5	1.0	8.5	ns	2-6

*Voltage Range 5.0 is 5.0V ±0.5V

AC Operating Requirements: See Section 2 for Waveforms

Symbol	Parameter	V _{CC} * (V)	74ACT		54ACT		74ACT		Units	Fig. No.
			T _A = +25°C C _L = 50 pF		T _A = -55°C to +125°C C _L = 50 pF		T _A = -40°C to +85°C C _L = 50 pF			
			Typ	Guaranteed Minimum						
t _s	Setup Time, HIGH or LOW D _n to LE	5.0	1.5	4.0		4.5		4.5	ns	2-7
t _h	Hold Time, HIGH or LOW D _n to LE	5.0	-2.0	0		1.5		0	ns	2-7
t _w	LE Pulse Width, HIGH	5.0	2.0	3.0		5.0		3.0	ns	2-4

*Voltage Range 5.0 is 5.0V ±0.5V

Capacitance

Symbol	Parameter	Typ	Units	Conditions
C_{IN}	Input Capacitance	4.5	pF	$V_{CC} = OPEN$
C_{PD}	Power Dissipation Capacitance	50.0	pF	$V_{CC} = 5.0V$