

PNP Silicon Planar Medium Power Transistors

ZTX750 ZTX751
ZTX752 ZTX753

FEATURES

- 1.5W power dissipation at $T_{amb} = 25^{\circ}\text{C}^*$
- 2V continuous I_C
- Excellent gain characteristics to 2A
- High V_{CE0} : up to 100V
- Low saturation voltages
- Guaranteed h_{FE} specified up to 2A
- Fast switching
- Exceptional price-to-power ratio
- Complementary types

DESCRIPTION

A range of high performance medium power transistors encapsulated in the popular E-line (TO-92) plastic package.

The 1.5W performance and outstanding electrical characteristics permit use in a wide variety of industrial and consumer applications including lamp and solenoid drivers, audio amplifiers and complementary drivers for hi-fi amplifiers.

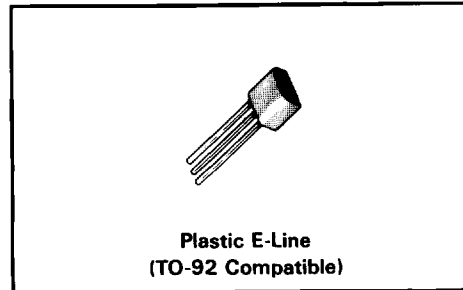

In addition to achieving excellent linearity the devices are designed to function as high speed power switching transistors.

The specially selected silicone encapsulation provides resistance to severe environments comparable with metal can devices.

Complementary to ZTX650 series.

ABSOLUTE MAXIMUM RATINGS

Parameter	Symbol	ZTX750	ZTX751	ZTX752	ZTX753	Unit
Collector-base voltage	V_{CBO}	- 60	- 80	- 100	- 120	V
Collector-emitter voltage	V_{CEO}	- 45	- 60	- 80	- 100	V
Emitter-base voltage	V_{EBO}	- 5				V
Peak pulse current (see note below)	I_{CM}	- 6				A
Continuous collector current	I_C	- 2				A
Practical power dissipation*	P_{totP}	1.5				W
Power dissipation at $T_{amb} = 25^{\circ}\text{C}$ derate above 25°C at $T_{case} = 25^{\circ}\text{C}$	P_{tot}	1				W
		5.7				mW/ $^{\circ}\text{C}$
		2.5				W
Operating & storage temp. range	$t_j : t_{stg}$	- 55 to + 200				$^{\circ}\text{C}$

Note: Consult Safe Operating Area graph for conditions.

*The power which can be dissipated assuming device mounted in typical manner on P.C.B. with copper equal to 1 sq.inch minimum.

ZTX750 ZTX751

CHARACTERISTICS (at $T_{amb} = 25^{\circ}\text{C}$ unless otherwise stated).

Parameter	Symbol	ZTX750			ZTX751			Unit	Conditions
		Min.	Typ.	Max.	Min.	Typ.	Max.		
Collector-base breakdown voltage	$V_{(BR)CBO}$	-60	-	-	-80	-	-	V	$I_C = -100\mu\text{A}$
Collector-emitter breakdown voltage	$V_{(BR)CEO}$	-45	-	-	-60	-	-	V	$I_C = -10\text{mA}$
Emitter-base breakdown voltage	$V_{(BR)EBO}$	-5	-	-	-5	-	-	V	$I_E = -100\mu\text{A}$
Collector cut-off current	I_{CBO}	-	-	-0.1	-	-	-	μA	$V_{CB} = -45\text{V}$
		-	-	-10	-	-	-	μA	$V_{CB} = -45\text{V}, T_{amb} = 100^{\circ}\text{C}$
		-	-	-	-	-	-0.1	μA	$V_{CB} = -60\text{V}$
		-	-	-	-	-	-10	μA	$V_{CB} = -60\text{V}, T_{amb} = 100^{\circ}\text{C}$
Emitter cut-off current	I_{EBO}	-	-	-0.1	-	-	-0.1	μA	$V_{EB} = -4\text{V}$
Collector-emitter saturation voltage	$V_{CE(sat)}$	-	0.15	-0.3	-	0.15	-0.3	V	$I_C = -1\text{A}, I_B = -100\text{mA}^*$
		-	0.28	-0.5	-	0.28	-0.5	V	$I_C = -2\text{A}, I_B = -200\text{mA}^*$
Base-emitter saturation voltage	$V_{BE(sat)}$	-	-0.90	-1.25	-	-0.90	-1.25	V	$I_C = -1\text{A}, I_B = -100\text{mA}^*$
Base-emitter turn-on voltage	$V_{BE(on)}$	-	-0.8	-1.0	-	-0.8	-1.0	V	$I_C = -1\text{A}, V_{CE} = -2\text{V}^*$
Static forward current transfer ratio	h_{FE}	70	200	-	70	200	-		$I_C = -50\text{mA}, V_{CE} = -2\text{V}^*$
		100	200	300	100	200	300		$I_C = -500\text{mA}, V_{CE} = -2\text{V}^*$
		80	170	-	80	170	-		$I_C = -1\text{A}, V_{CE} = -2\text{V}^*$
		40	150	-	40	150	-		$I_C = -2\text{A}, V_{CE} = -2\text{V}^*$
Transition frequency	f_T	100	140	-	100	140	-	MHz	$I_C = -100\text{mA}, V_{CE} = -5\text{V}$ $f = 100\text{MHz}$
Switching times	T_{on}	-	40	-	-	40	-	ns	} $I_C = -500\text{mA}, I_{B1} = -50\text{mA}$ $I_{B2} = -50\text{mA}, V_{CC} = -10\text{V}$
	T_{off}	-	450	-	-	450	-	ns	
Output capacitance	C_{obo}	-	-	30	-	-	30	pF	$V_{CB} = -10\text{V}, f = 1\text{MHz}$

*Measured under pulsed conditions. Pulse width = 300 μs . Duty cycle $\leq 2\%$.

THERMAL CHARACTERISTICS (ZTX750/3)

Parameter	Symbol	Maximum	Unit
Thermal resistance: Junction to ambient ₁	$R_{th(j-amb)1}$	175	$^{\circ}\text{C/W}$
Junction to ambient ₂	$R_{th(j-amb)2}^{\dagger}$	116	$^{\circ}\text{C/W}$
Junction to case	$R_{th(j-case)}$	70	$^{\circ}\text{C/W}$

\dagger Device mounted on P.C.B. with copper equal to 1 sq.inch minimum.

ZTX752 ZTX753

CHARACTERISTICS (at $T_{amb} = 25^{\circ}\text{C}$ unless otherwise stated).

Parameter	Symbol	ZTX752			ZTX753			Unit	Conditions
		Min.	Typ.	Max.	Min.	Typ.	Max.		
Collector-base breakdown voltage	$V_{(BR)CBO}$	-100	-	-	-120	-	-	V	$I_C = -100\mu\text{A}$
Collector-emitter breakdown voltage	$V_{(BR)CEO}$	-80	-	-	-100	-	-	V	$I_C = -10\text{mA}$
Emitter-base breakdown voltage	$V_{(BR)EBO}$	-5	-	-	-5	-	-	V	$I_E = -100\mu\text{A}$
Collector cut-off current	I_{CBO}	-	-	-0.1	-	-	-	μA	$V_{CB} = -80\text{V}$
		-	-	-10	-	-	-	μA	$V_{CB} = -80\text{V}, T_{amb} = 100^{\circ}\text{C}$
		-	-	-	-	-	-0.1	μA	$V_{CB} = -100\text{V}$
		-	-	-	-	-	-10	μA	$V_{CB} = -100\text{V}, T_{amb} = 100^{\circ}\text{C}$
Emitter cut-off current	I_{EBO}	-	-	-0.1	-	-	-0.1	μA	$V_{EB} = -4\text{V}$
Collector-emitter saturation voltage	$V_{CE(sat)}$	-	0.17	-0.3	-	0.17	-0.3	V	$I_C = -1\text{A}, I_B = -100\text{mA}^*$
		-	0.30	-0.5	-	0.30	-0.5	V	$I_C = -2\text{A}, I_B = -200\text{mA}^*$
Base-emitter saturation voltage	$V_{BE(sat)}$	-	-0.90	-1.25	-	-0.90	-1.25	V	$I_C = -1\text{A}, I_B = -100\text{mA}^*$
Base-emitter turn-on voltage	$V_{BE(on)}$	-	-0.8	-1.0	-	-0.8	-1.0	V	$I_C = -1\text{A}, V_{CE} = -2\text{V}^*$
Static forward current transfer ratio	h_{FE}	70	200	-	70	200	-		$I_C = -50\text{mA}, V_{CE} = -2\text{V}^*$
		100	200	300	100	200	300		$I_C = -500\text{mA}, V_{CE} = -2\text{V}^*$
		55	170	-	55	170	-		$I_C = -1\text{A}, V_{CE} = -2\text{V}^*$
		25	55	-	25	55	-		$I_C = -2\text{A}, V_{CE} = -2\text{V}^*$
Transition frequency	f_T	100	140	-	100	140	-	MHz	$I_C = -100\text{mA}, V_{CE} = -5\text{V}$ $f = 100\text{MHz}$
Switching times	T_{on}	-	40	-	-	40	-	ns	} $I_C = -500\text{mA}, I_{B1} = -50\text{mA}$ } $I_{B2} = -50\text{mA}, V_{CC} = -10\text{V}$
	T_{off}	-	600	-	-	600	-	ns	
Output capacitance	C_{obo}	-	-	30	-	-	30	pF	$V_{CB} = -10\text{V}, f = 1\text{MHz}$

*Measured under pulsed conditions. Pulse width = $300\mu\text{s}$. Duty cycle $\leq 2\%$.

ZTX750 ZTX751 ZTX752 ZTX753

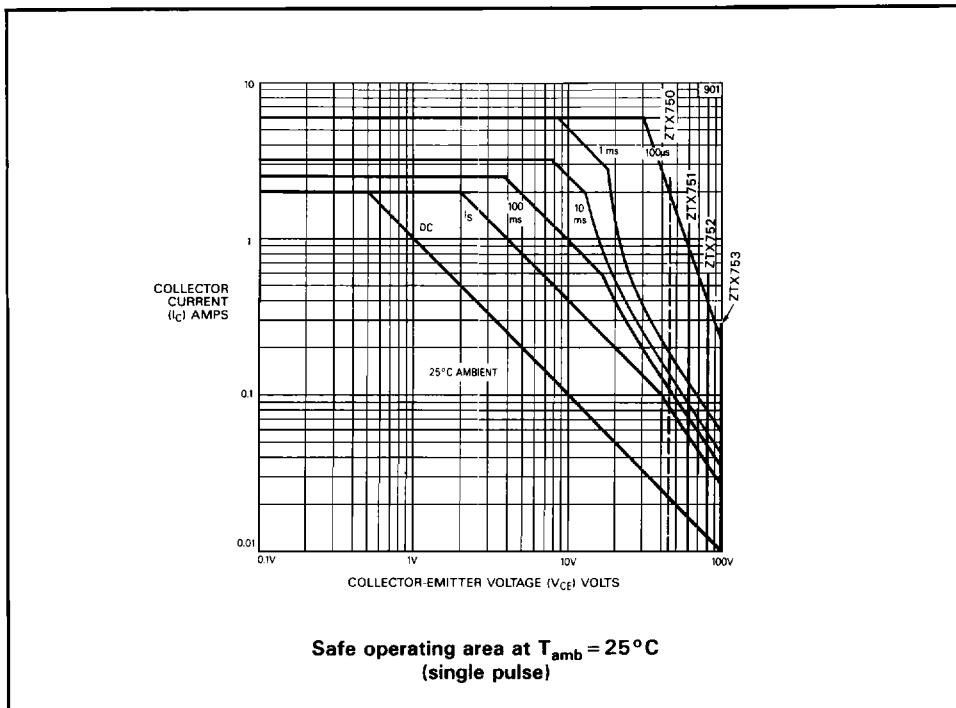
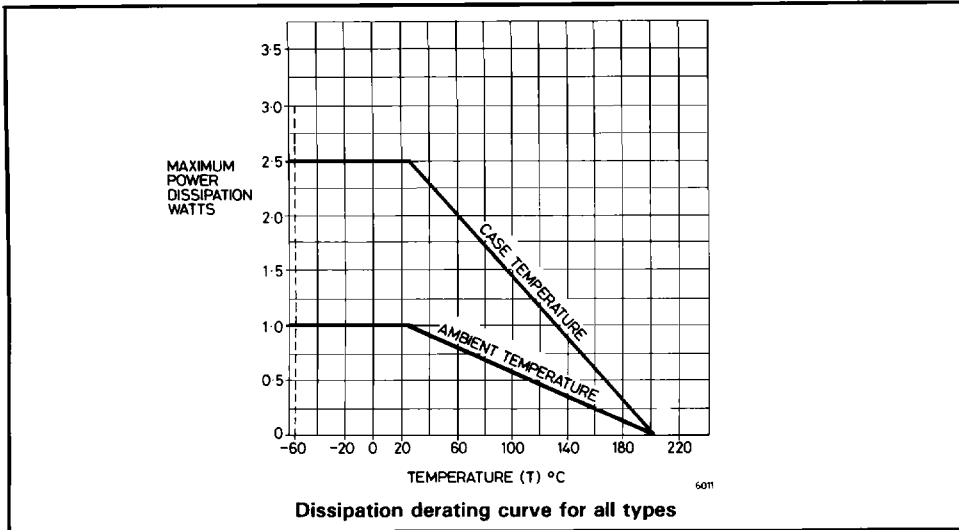

ZTX750 ZTX751 ZTX752 ZTX753

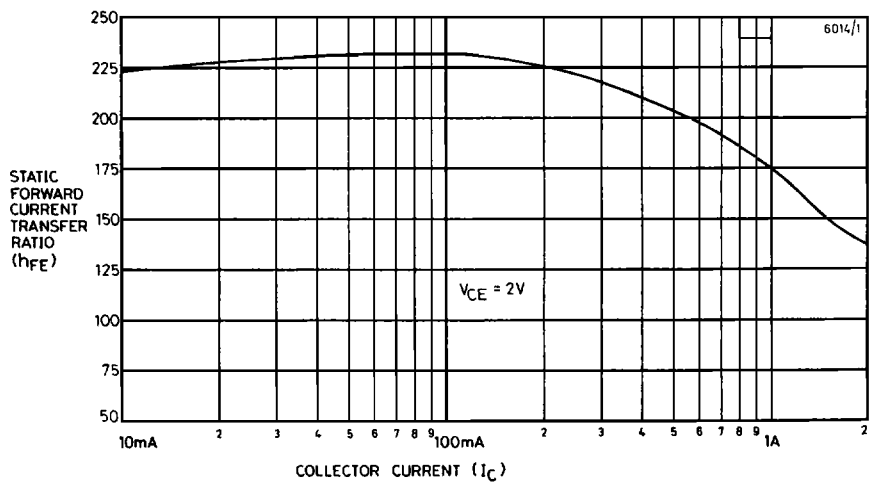

Static forward current transfer ratio plotted against collector current for ZTX750/ZTX751

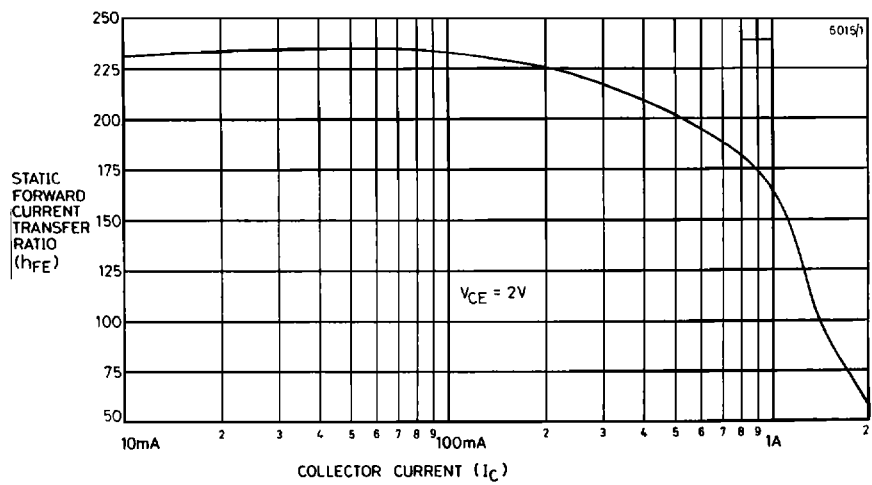

Static forward current transfer ratio plotted against collector current for ZTX752/ZTX753

Typical characteristics

ZTX750 ZTX751 ZTX752 ZTX753

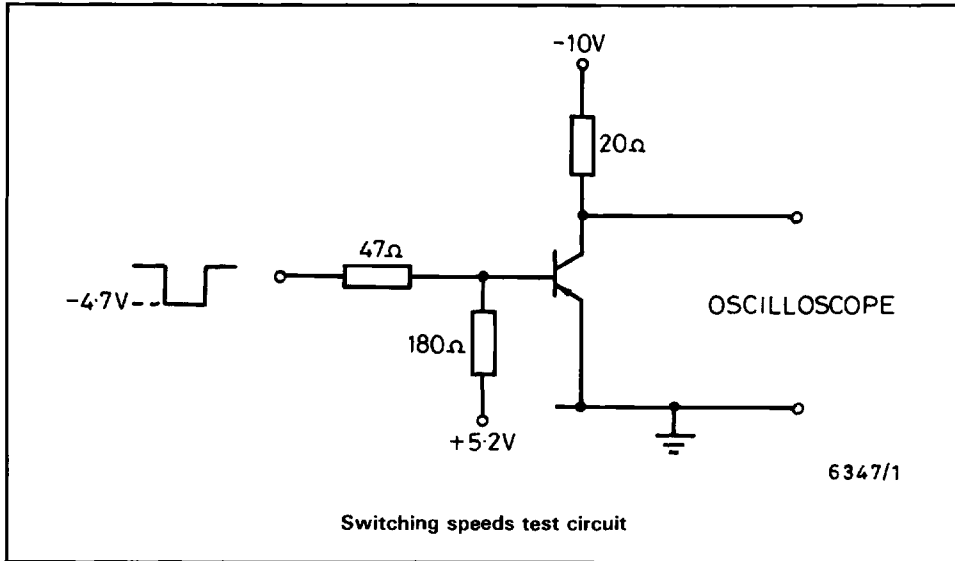
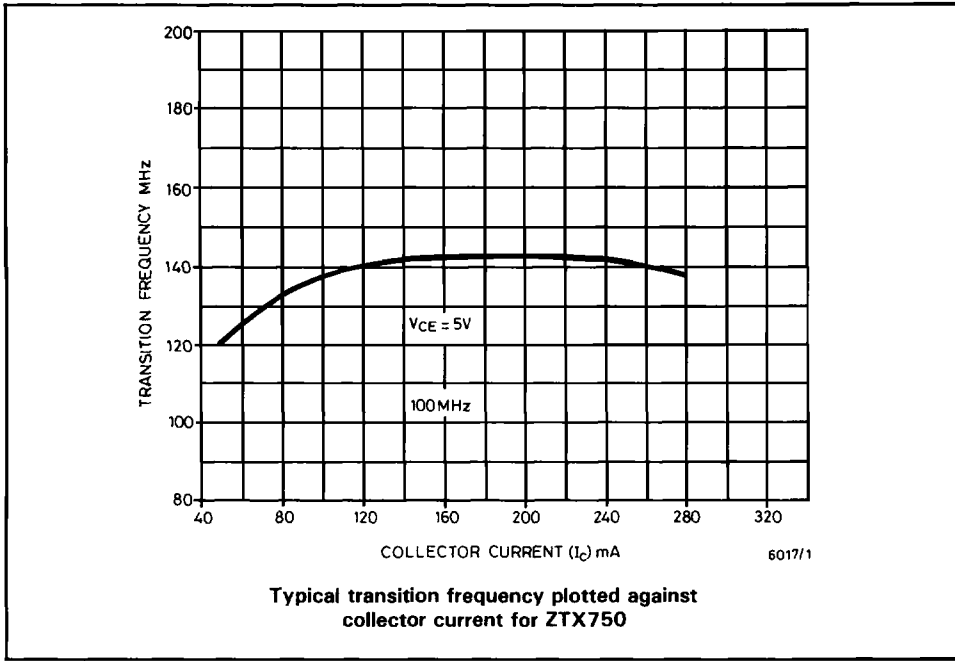

ZTX750 ZTX751 ZTX752 ZTX753

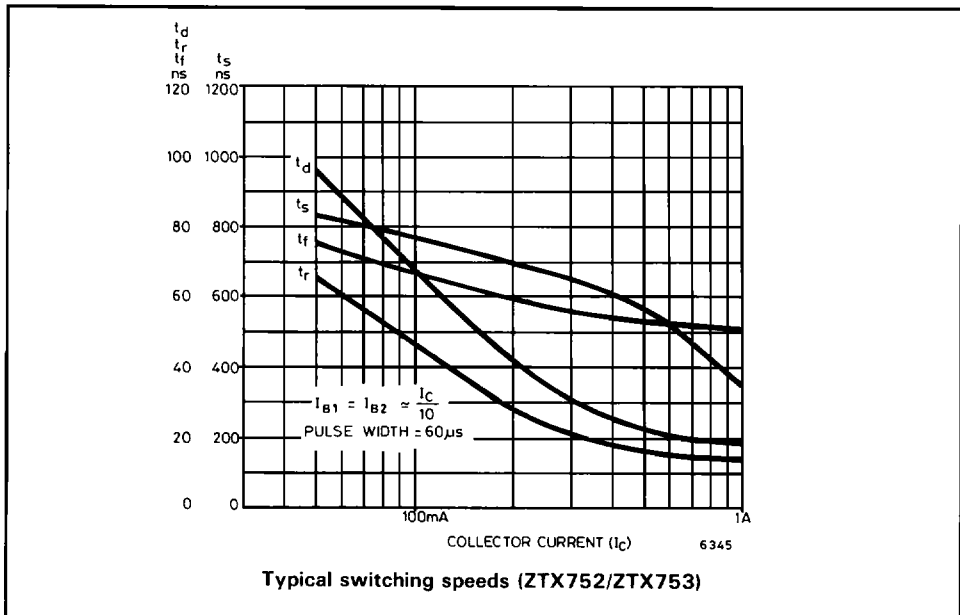
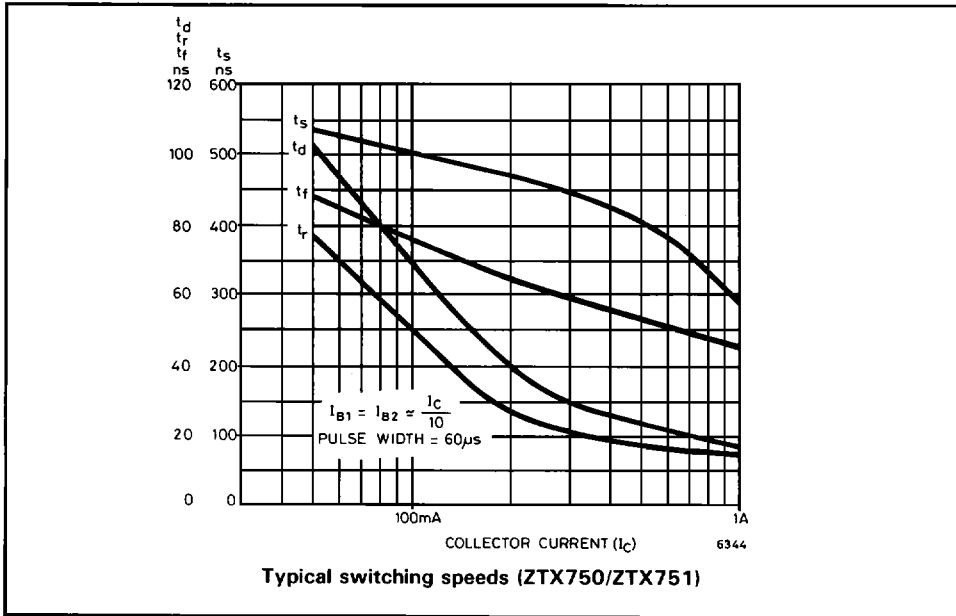

ZTX750 ZTX751 ZTX752 ZTX753

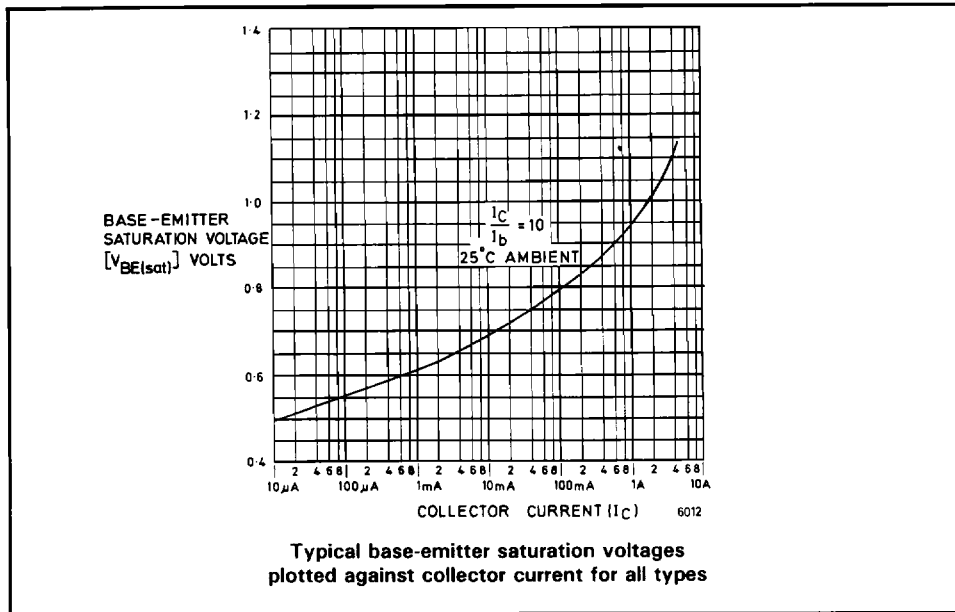
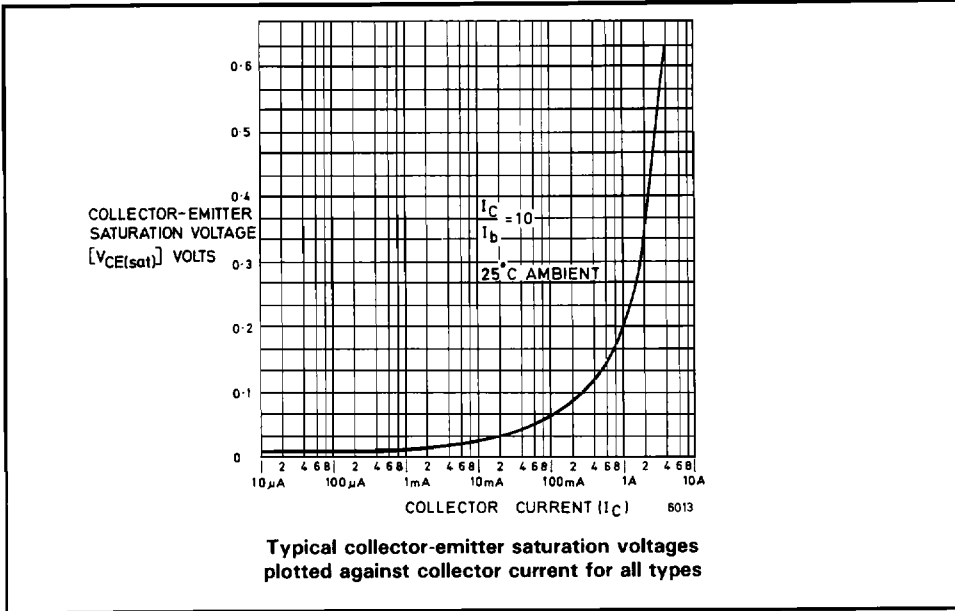

ZTX750 ZTX751 ZTX752 ZTX753

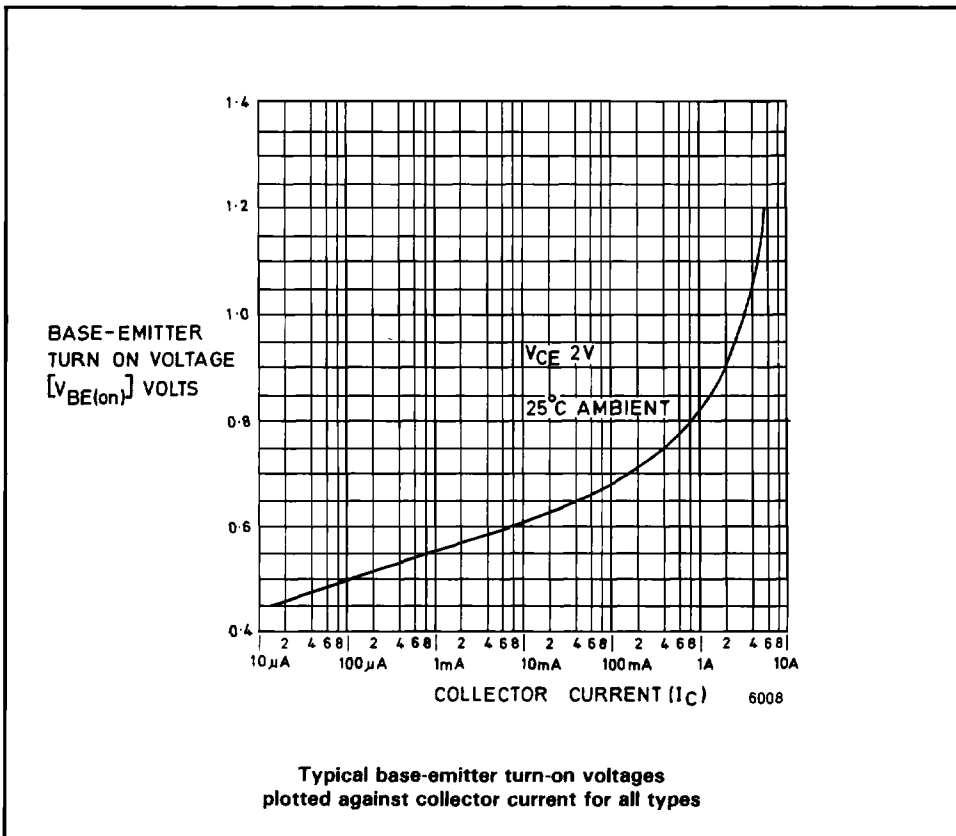

ZTX750 ZTX751 ZTX752 ZTX753

