

MMPQ2222A
SURFACE MOUNT
NPN SILICON
QUAD TRANSISTORS



www.centrasemi.com

DESCRIPTION:

The CENTRAL SEMICONDUCTOR MMPQ2222A, consisting of four transistors and available in the SOIC-16 surface mount package, is designed for general purpose amplifier and switching applications.

MARKING: FULL PART NUMBER



SOIC-16 CASE

MAXIMUM RATINGS: ($T_A=25^\circ\text{C}$)

Collector-Base Voltage
Collector-Emitter Voltage
Emitter-Base Voltage
Continuous Collector Current
Power Dissipation
Operating and Storage Junction Temperature
Thermal Resistance (Total Package)
Thermal Resistance (Each Transistor)

SYMBOL		UNITS
V_{CBO}	75	V
V_{CEO}	40	V
V_{EBO}	6.0	V
I_C	500	mA
P_D	1.0	W
T_J, T_{stg}	-55 to +150	$^\circ\text{C}$
θ_{JA}	125	$^\circ\text{C/W}$
θ_{JA}	240	$^\circ\text{C/W}$

ELECTRICAL CHARACTERISTICS: ($T_A=25^\circ\text{C}$ unless otherwise noted)

SYMBOL	TEST CONDITIONS	MIN	TYP	MAX	UNITS
I_{CEV}	$V_{CE}=60\text{V}, V_{EB}=3.0\text{V}$			10	nA
I_{CBO}	$V_{CB}=60\text{V}$			10	nA
I_{CBO}	$V_{CB}=60\text{V}, T_A=125^\circ\text{C}$			10	μA
I_{EBO}	$V_{BE}=3.0\text{V}$			10	nA
BV_{CBO}	$I_C=10\mu\text{A}$	75			V
BV_{CEO}	$I_C=10\text{mA}$	40			V
BV_{EBO}	$I_E=10\mu\text{A}$	6.0			V
$V_{CE(SAT)}$	$I_C=150\text{mA}, I_B=15\text{mA}$			0.3	V
$V_{CE(SAT)}$	$I_C=500\text{mA}, I_B=50\text{mA}$			1.0	V
$V_{BE(SAT)}$	$I_C=150\text{mA}, I_B=15\text{mA}$	0.6		1.2	V
$V_{BE(SAT)}$	$I_C=500\text{mA}, I_B=50\text{mA}$			2.0	V
h_{FE}	$V_{CE}=10\text{V}, I_C=0.1\text{mA}$	35			
h_{FE}	$V_{CE}=10\text{V}, I_C=1.0\text{mA}$	50			
h_{FE}	$V_{CE}=10\text{V}, I_C=10\text{mA}$	75			
h_{FE}	$V_{CE}=10\text{V}, I_C=10\text{mA}, T_A=-55^\circ\text{C}$	35			
h_{FE}	$V_{CE}=10\text{V}, I_C=150\text{mA}$	100		300	
h_{FE}	$V_{CE}=1.0\text{V}, I_C=150\text{mA}$	50			
h_{FE}	$V_{CE}=10\text{V}, I_C=500\text{mA}$	40			
f_T	$V_{CE}=20\text{V}, I_C=20\text{mA}, f=100\text{MHz}$		300		MHz
C_{ib}	$V_{EB}=0.5\text{V}, f=100\text{kHz}$		20		pF
C_{ob}	$V_{CB}=10\text{V}, f=100\text{kHz}$		4.0		pF
NF	$V_{CE}=10\text{V}, I_C=100\mu\text{A}, R_S=1.0\text{k}\Omega, f=1.0\text{kHz}$			2.0	dB

R2 (1-March 2010)

MMPQ2222A
SURFACE MOUNT
NPN SILICON
QUAD TRANSISTORS



ELECTRICAL CHARACTERISTICS - Continued: ($T_A=25^\circ\text{C}$ unless otherwise noted)

SYMBOL	TEST CONDITIONS	TYP	UNITS
t_d	$V_{CC}=30\text{V}$, $V_{BE(OFF)}=0.5\text{V}$, $I_C=150\text{mA}$, $I_{B1}=15\text{mA}$	8.0	ns
t_r	$V_{CC}=30\text{V}$, $V_{BE(OFF)}=0.5\text{V}$, $I_C=150\text{mA}$, $I_{B1}=15\text{mA}$	20	ns
t_s	$V_{CC}=30\text{V}$, $I_C=150\text{mA}$, $I_{B1}=I_{B2}=15\text{mA}$	180	ns
t_f	$V_{CC}=30\text{V}$, $I_C=150\text{mA}$, $I_{B1}=I_{B2}=15\text{mA}$	40	ns

SOIC-16 CASE - MECHANICAL OUTLINE

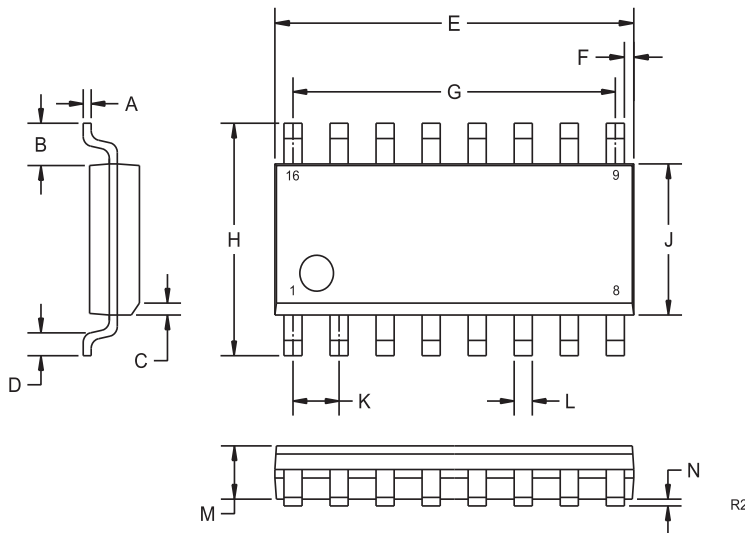

PIN CONFIGURATION

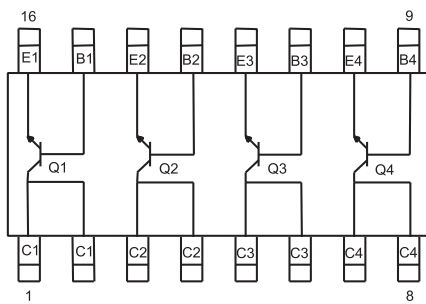

MARKING: FULL PART NUMBER

SYMBOL	INCHES		MILLIMETERS	
	MIN	MAX	MIN	MAX
A	0.007	0.010	0.19	0.25
B	0.041		1.04	
C	0.010	0.020	0.25	0.50
D	0.020	0.035	0.50	0.90
E	0.386	0.394	9.80	10.00
F	0.010		0.25	
G	0.350		8.89	
H	0.228	0.244	5.80	6.20
J	0.150	0.157	3.80	4.00
K	0.050		1.27	
L	0.0138	0.0201	0.35	0.51
M	0.0531	0.0689	1.35	1.75
N	0.0039	0.0098	0.10	0.25

SOIC-16 (REV:R2)

R2 (1-March 2010)