

SN54HCT640, SN54HCT643, SN54HCT645 SN74HCT640, SN74HCT643, SN74HCT645 OCTAL BUS TRANSCEIVERS WITH 3-STATE OUTPUTS

D2804, MARCH 1984—REVISED SEPTEMBER 1987

- Inputs are TTL-Voltage Compatible
- Choice of True or Inverting Logic
- High-Current 3-State Outputs Can Drive Up to 15 LSTTL Loads
- Package Options Include Plastic "Small Outline" Packages, Ceramic Chip Carriers, and Standard Plastic and Ceramic 300-mil DIPs
- Dependable Texas Instruments Quality and Reliability

DEVICE	LOGIC
'HCT640	Inverting
'HCT643	True and Inverting
'HCT645	True

description

These octal bus transceivers are designed for asynchronous two-way communication between data buses. The devices transmit data from the A bus to the B bus or from the B bus to the A bus depending upon the level at the direction control (DIR) input. The enable input (\bar{G}) can be used to disable the device so the buses are effectively isolated.

The SN54HCT640, SN54HCT643, and SN54HCT645 are characterized for operation over the full military temperature range of -55°C to 125°C . The SN74HCT640, SN74HCT643 and SN74HCT645 are characterized for operation from -40°C to 85°C .

SN54HCT'... J PACKAGE
SN74HCT'... DW OR N PACKAGE
(TOP VIEW)

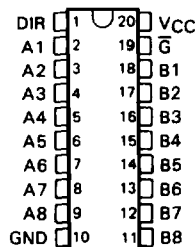

SN54HCT'... FK PACKAGE
(TOP VIEW)

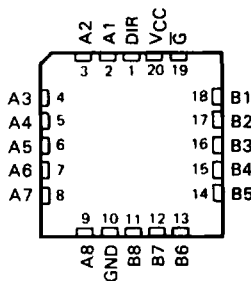

FUNCTION TABLE

CONTROL INPUTS		OPERATION		
		'HCT640	'HCT643	'HCT645
\bar{G}	DIR	\bar{B} data to A bus	B data to A bus	B data to A bus
L	L	\bar{A} data to B bus	\bar{A} data to B bus	A data to B bus
L	H	Isolation	Isolation	Isolation
H	X	Isolation	Isolation	Isolation

PRODUCTION DATA documents contain information current as of publication date. Products conform to specifications per the terms of Texas Instruments standard warranty. Production processing does not necessarily include testing of all parameters.

TEXAS
INSTRUMENTS

POST OFFICE BOX 655012 • DALLAS, TEXAS 75265

Copyright © 1984, Texas Instruments Incorporated

2-553

2

HCMOS Devices

**SN54HCT640, SN54HCT643, SN54HCT645
SN74HCT640, SN74HCT643, SN74HCT645
OCTAL BUS TRANSCEIVERS WITH 3-STATE OUTPUTS**

logic symbols†

2

HC MOS Devices

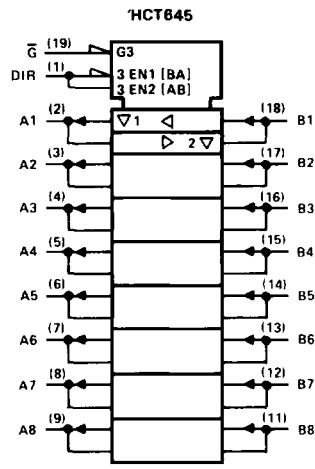
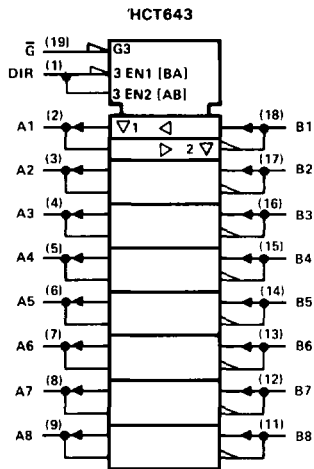
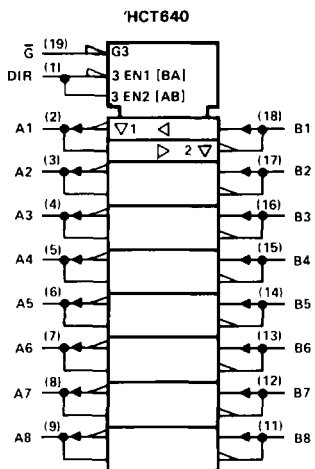

†These symbols are in accordance with ANSI/IEEE Std 91-1984 and IEC Publication 617-12.

logic diagrams (positive logic)

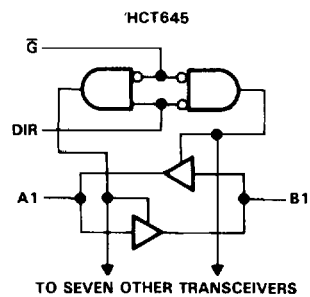
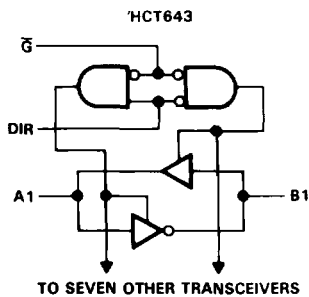
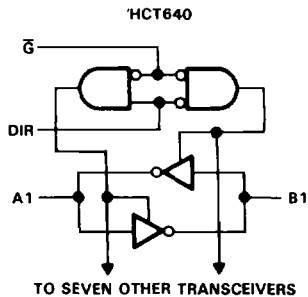

**SN54HCT640, SN54HCT643, SN54HCT645
SN74HCT640, SN74HCT643, SN74HCT645
OCTAL BUS TRANSCEIVERS WITH 3-STATE OUTPUTS**

absolute maximum ratings over operating free-air temperature range†

Supply voltage, V_{CC}	-0.5 V to 7 V
Input clamp current, I_{IK} ($V_I < 0$ or $V_I > V_{CC}$)	± 20 mA
Output clamp current, I_{OK} ($V_O < 0$ or $V_O > V_{CC}$)	± 20 mA
Continuous output current, I_O ($V_O = 0$ to V_{CC})	± 35 mA
Continuous current through V_{CC} or GND pins	± 70 mA
Lead temperature 1,6 mm (1/16 in) from case for 60 s: FK or J package	300°C
Lead temperature 1,6 mm (1/16 in) from case for 10 s: DW or N package	260°C
Storage temperature range	-65°C to 150°C

† Stresses beyond those listed under "absolute maximum ratings" may cause permanent damage to the device. These are stress ratings only, and functional operation of the device at these or any other conditions beyond those indicated under "recommended operating conditions" is not implied. Exposure to absolute-maximum-rated conditions for extended periods may affect device reliability.

recommended operating conditions

		SN54HCT640 SN54HCT643 SN54HCT645			SN74HCT640 SN74HCT643 SN74HCT645			UNIT
		MIN	NOM	MAX	MIN	NOM	MAX	
V_{CC}	Supply voltage	4.5	5	5.5	4.5	5	5.5	V
V_{IH}	High-level input voltage	$V_{CC} = 4.5$ V to 5.5 V			2			V
V_{IL}	Low-level input voltage	$V_{CC} = 4.5$ V to 5.5 V			0			V
V_I	Input voltage	0			V_{CC}			V
V_O	Output voltage	0			V_{CC}			V
t_t	Input transition (rise and fall) times	0			500			ns
T_A	Operating free-air temperature	-55			125			°C

electrical characteristics over recommended operating free-air temperature range (unless otherwise noted)

PARAMETER	TEST CONDITIONS	V_{CC}	$T_A = 25^\circ\text{C}$			SN54HCT640	SN74HCT640	UNIT	
			MIN	TYP	MAX	SN54HCT643 SN54HCT645	SN74HCT643 SN74HCT645		
V_{OH}	$V_I = V_{IH}$ or V_{IL} , $I_{OH} = -20$ μA	4.5 V	4.4	4.499		4.4	4.4	V	
	$V_I = V_{IH}$ or V_{IL} , $I_{OH} = -6$ mA	4.5 V	3.98	4.30	3.7	3.84			
V_{OL}	$V_I = V_{IH}$ or V_{IL} , $I_{OL} = 20$ μA	4.5 V		0.001	0.1	0.1	0.1	V	
	$V_I = V_{IH}$ or V_{IL} , $I_{OL} = 6$ mA	4.5 V		0.17	0.26	0.4	0.33		
I_I	DIR or \bar{G}	$V_I = V_{CC}$ or 0	5.5 V	± 0.1	± 100	± 1000	± 1000	nA	
I_{OZ}	A or B	$V_O = V_{CC}$ or 0	5.5 V	± 0.01	± 0.5	± 10	± 5	μA	
I_{CC}		$V_I = V_{CC}$ or 0, $I_O = 0$	5.5 V		8	160	80	μA	
ΔI_{CC}^\ddagger		One input at 0.5 V or 2.4 V Other inputs at 0 V or V_{CC}	5.5 V		1.4	2.4	3	2.9	mA
C_i	DIR or \bar{G}		4.5 to 5.5 V		3	10	10	10	pF

‡ This is the increase in supply current for each input that is at one of the specified TTL voltage levels rather than 0 V or V_{CC} .

2

HC MOS Devices



**SN54HCT640, SN54HCT643
SN74HCT640, SN74HCT643
OCTAL BUS TRANSCEIVERS WITH 3-STATE OUTPUTS**

switching characteristics over recommended operating free-air temperature range (unless otherwise noted), $C_L = 50$ pF (see Note 1)

PARAMETER	FROM (INPUT)	TO (OUTPUT)	V _{CC}	T _A = 25 °C			SN54HCT640 SN54HCT643		SN74HCT640 SN74HCT643		UNIT
				MIN	TYP	MAX	MIN	MAX	MIN	MAX	
t _{pd}	A or B	B or A	4.5 V	14	21		32		25	ns	
			5.5 V	12	18		27		23		
t _{en}	\bar{C}	A or B	4.5 V	27	35		53		44	ns	
			5.5 V	24	32		47		39		
t _{dis}	\bar{C}	A or B	4.5 V	20	30		45		38	ns	
			5.5 V	18	26		41		34		
t _t		A or B	4.5 V	9	12		18		15	ns	
			5.5 V	8	11		16		14		

C _{pd}	Power dissipation capacitance per transceiver	No load, T _A = 25 °C	40 pF typ
-----------------	---	---------------------------------	-----------

switching characteristics over recommended operating free-air temperature range (unless otherwise noted), $C_L = 150$ pF (see Note 1)

PARAMETER	FROM (INPUT)	TO (OUTPUT)	V _{CC}	T _A = 25 °C			SN54HCT640 SN54HCT643		SN74HCT640 SN74HCT643		UNIT
				MIN	TYP	MAX	MIN	MAX	MIN	MAX	
t _{pd}	A or B	B or A	4.5 V	17	27		41		34	ns	
			5.5 V	15	24		37		30		
t _{en}	\bar{C}	A or B	4.5 V	31	45		68		56	ns	
			5.5 V	28	41		61		51		
t _t		A or B	4.5 V	17	42		63		53	ns	
			5.5 V	14	38		57		48		

NOTE 1: Load circuits and voltage waveforms are shown in Section 1.

2

HC MOS Devices

SN54HCT645, SN74HCT645 OCTAL BUS TRANSCEIVERS WITH 3-STATE OUTPUTS

switching characteristics over recommended operating free-air temperature range (unless otherwise noted), $C_L = 50$ pF (see Note 1)

PARAMETER	FROM (INPUT)	TO (OUTPUT)	VCC	$T_A = 25^\circ\text{C}$			SN54HCT645		SN74HCT645		UNIT
				MIN	TYP	MAX	MIN	MAX	MIN	MAX	
t_{pd}	A or B	B or A	4.5 V	16	22		33		28	ns	
			5.5 V	14	20		30		25		
t_{en}	\bar{G}	A or B	4.5 V		25	46		69		58	ns
			5.5 V		22	41		62		52	
t_{dis}	\bar{G}	A or B	4.5 V		26	40		60		50	ns
			5.5 V		23	36		54		45	
t_t		A or B	4.5 V		9	12		18		15	ns
			5.5 V		8	11		16		14	

C_{pd}	Power dissipation capacitance per transceiver	No load, $T_A = 25^\circ\text{C}$	40 pF typ
----------	---	-----------------------------------	-----------

switching characteristics over recommended operating free-air temperature range (unless otherwise noted), $C_L = 150$ pF (see Note 1)

PARAMETER	FROM (INPUT)	TO (OUTPUT)	VCC	$T_A = 25^\circ\text{C}$			SN54HCT645		SN74HCT645		UNIT
				MIN	TYP	MAX	MIN	MAX	MIN	MAX	
t_{pd}	A or B	B or A	4.5 V	20	30		45		38	ns	
			5.5 V	18	27		41		34		
t_{en}	\bar{G}	A or B	4.5 V		36	59		89		74	ns
			5.5 V		30	53		80		67	
t_t		A or B	4.5 V		17	42		63		53	ns
			5.5 V		14	38		57		48	

NOTE 1: Load circuits and voltage waveforms are shown in Section 1.

2

HCMOS Devices

TEXAS
INSTRUMENTS

POST OFFICE BOX 655012 • DALLAS, TEXAS 75265

2-557