

- NOTES:
- 1) HOUSING MATERIAL: GLASS FILLED HIGH TEMP THERMOPLASTIC, COLOR: BLACK
 - 2) TERMINAL MATERIAL: PHOSPHOR BRONZE
 - 3) SEE SHT 2 & 3 FOR CKT SIZE, PART NUMBERS AND OVERALL DIMENSIONS, SEE SHT 4 FOR VOIDS.
 - 4) FOR ILLUSTRATION, 6 CKT ASSY SHOWN.
 - 5) REFER TO PRODUCT SPEC PS-79107 PLATING OPTION 3 NOT COVERED BY PS-79107.
 - 6) PACKAGING PER PK-70873-0180
 - 7) CKTS NUMBERED FROM LEFT TO RIGHT WHEN PART IS VIEWED FROM TOP WITH RECESS ON THE RIGHT AS SHOWN.

PLATING OPTION:

- | | |
|---|--|
| 1) - 30u"/0.76um MIN GOLD PLATE IN SELECTED AREA
75u"/1.90um MIN TIN/LEAD PLATE IN SELECTED AREA
BOTH OVER 50u"/1.25um MIN NICKEL OVERALL | 4) - 30u"/0.76um MIN GOLD PLATE IN SELECTED AREA
75u"/1.90um MIN TIN PLATE IN SELECTED AREA
BOTH OVER 50u"/1.25um MIN NICKEL OVERALL |
| 2) - 15u"/0.38um MIN GOLD PLATE IN SELECTED AREA
75u"/1.90um MIN TIN/LEAD PLATE IN SELECTED AREA
BOTH OVER 50u"/1.25um MIN NICKEL OVERALL | 5) - 15u"/0.38um MIN GOLD PLATE IN SELECTED AREA
75u"/1.90um MIN TIN PLATE IN SELECTED AREA
BOTH OVER 50u"/1.25um MIN NICKEL OVERALL |
| 3) - 2u"/0.05um MIN GOLD PLATE IN SELECTED AREA
40u"/1.02um MIN TIN/LEAD PLATE IN SELECTED AREA
BOTH OVER 40u"/1.02um MIN NICKEL OVERALL | 6) - 2u"/0.05um MIN GOLD PLATE IN SELECTED AREA
40u"/1.02um MIN TIN PLATE IN SELECTED AREA
BOTH OVER 40u"/1.02um MIN NICKEL OVERALL |

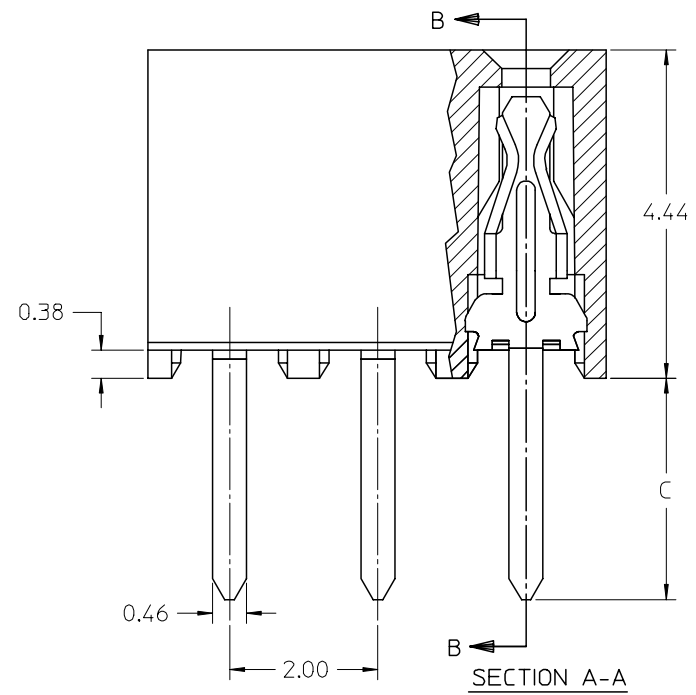

CHANGE TOLERANCES EC NO: S2006-0225 DRWN: LUI/AO 2005/09/09 CHKD: BOKOK 2005/09/09 APPR: PTL/IM 2005/09/09	QUALITY SYMBOLS ▽=0 ▽C=0	GENERAL TOLERANCES (UNLESS SPECIFIED)		DIMENSION STYLE MM ONLY		SCALE NTS	DESIGN UNITS METRIC	THIRD ANGLE PROJECTION			
		4 PLACES ± --- ± --- 3 PLACES ± --- ± --- 2 PLACES ± 0.25 ± --- 1 PLACE ± 0.38 ± ---	mm INCH	DRAWN BY AAB	DATE 1989/05/15	TITLE SALES DRAWING 2MM DUAL ROW VERTICAL RECEPTACLE T/H					
		ANGULAR ± 1/2°		CHECKED BY MJM	DATE 1989/05/15	MOLEX INCORPORATED					
		DRAFT WHERE APPLICABLE MUST REMAIN WITHIN DIMENSIONS		APPROVED BY WAZ	DATE 1989/05/15	MATERIAL NO. SEE TABLE	DOCUMENT NO. SDA-79107-****	SHEET NO. 1 OF 4			

TIN/LEAD OPTION

CKT SIZE	DIM 'A'	DIM 'B'	P.C.TAIL DIMENSION 'C' = 3.00				P.C.TAIL DIMENSION 'C' = 1.91							
			PLATING OPTION 2		PLATING OPTION 1		PLATING OPTION 3		PLATING OPTION 2		PLATING OPTION 1		PLATING OPTION 3	
			ITEM NO.		ITEM NO.		ITEM NO.		ITEM NO.		ITEM NO.		ITEM NO.	
04	(4.19)	(2.00)	79107-0001	79107-0051	X	79107-0126	79107-0201	79107-0251	X	79107-0326				
06	(6.19)	(4.00)	79107-0002	79107-0052	X	79107-0127	79107-0202	79107-0252	X	79107-0327				
08	(8.19)	(6.00)	79107-0003	79107-0053	X	79107-0128	79107-0203	79107-0253	X	79107-0328				
10	(10.19)	(8.00)	79107-0004	79107-0054	X	79107-0129	79107-0204	79107-0254	X	79107-0329				
12	(12.19)	(10.00)	79107-0005	79107-0055		79107-0130	79107-0205	79107-0255		79107-0330				
14	(14.19)	(12.00)	79107-0006	79107-0056	X	79107-0131	79107-0206	79107-0256	X	79107-0331				
16	(16.19)	(14.00)	79107-0007	79107-0057	X	79107-0132	79107-0207	79107-0257	X	79107-0332				
18	(18.19)	(16.00)	79107-0008	79107-0058	X	79107-0133	79107-0208	79107-0258	X	79107-0333				
20	(20.19)	(18.00)	79107-0009	79107-0059	X	79107-0134	79107-0209	79107-0259	X	79107-0334				
22	(22.19)	(20.00)	79107-0010	79107-0060	X	79107-0135	79107-0210	79107-0260	X	79107-0335				
24	(24.19)	(22.00)	79107-0011	79107-0061	X	79107-0136	79107-0211	79107-0261	X	79107-0336				
26	(26.19)	(24.00)	79107-0012	79107-0062	X	79107-0137	79107-0212	79107-0262	X	79107-0337				
28	(28.19)	(26.00)	79107-0013	79107-0063	X	79107-0138	79107-0213	79107-0263	X	79107-0338				
30	(30.19)	(28.00)	79107-0014	79107-0064	X	79107-0139	79107-0214	79107-0264	X	79107-0339				
32	(32.19)	(30.00)	79107-0015	79107-0065	X	79107-0140	79107-0215	79107-0265	X	79107-0340				
34	(34.19)	(32.00)	79107-0016	79107-0066	X	79107-0141	79107-0216	79107-0266	X	79107-0341				
36	(36.19)	(34.00)	79107-0017	79107-0067	X	79107-0142	79107-0217	79107-0267	X	79107-0342				
38	(38.19)	(36.00)	79107-0018	79107-0068	X	79107-0143	79107-0218	79107-0268	X	79107-0343				
40	(40.19)	(38.00)	79107-0019	79107-0069	X	79107-0144	79107-0219	79107-0269	X	79107-0344				
42	(42.19)	(40.00)	79107-0020	79107-0070	X	79107-0145	79107-0220	79107-0270	X	79107-0345				
44	(44.19)	(42.00)	79107-0021	79107-0071	X	79107-0146	79107-0221	79107-0271	X	79107-0346				
46	(46.19)	(44.00)	79107-0022	79107-0072	X	79107-0147	79107-0222	79107-0272	X	79107-0347				
48	(48.19)	(46.00)	79107-0023	79107-0073	X	79107-0148	79107-0223	79107-0273	X	79107-0348				
50	(50.19)	(48.00)	79107-0024	79107-0074	X	79107-0149	79107-0224	79107-0274	X	79107-0349				

X - DENOTES THE ITEM IS NOT AVAILABLE CURRENTLY.

CHANGE TOLERANCES EC NO: S2006-0225 DRWN: LOJ/AO CHKD: BOKK APPR: PTL/IM 2005/09/09 2005/09/09 2005/09/10	QUALITY SYMBOLS ▽=0 ▽=0	GENERAL TOLERANCES (UNLESS SPECIFIED)		DIMENSION STYLE MM ONLY		SCALE NTS	DESIGN UNITS METRIC	THIRD ANGLE PROJECTION	
		4 PLACES ± --- ± --- 3 PLACES ± --- ± --- 2 PLACES ± 0.25 ± --- 1 PLACE ± 0.38 ± --- ANGULAR ±1/2°		DRAWN BY DATE AAB 1989/05/15		TITLE SALES DRAWING 2MM DUAL ROW VERTICAL RECEPTACLE T/H			
		DRAFT WHERE APPLICABLE MUST REMAIN WITHIN DIMENSIONS		APPROVED BY DATE WAZ 1989/05/15		MOLEX INCORPORATED			
		MATERIAL NO. SEE TABLE		DOCUMENT NO. SDA-79107-****		SHEET NO. 2 OF 4			

TIN OPTION

CKT SIZE	DIM 'A'	DIM 'B'	P.C.TAIL DIMENSION 'C' = 3.00			P.C.TAIL DIMENSION 'C' = 1.91		
			PLATING OPTION 5	PLATING OPTION 4	PLATING OPTION 6	PLATING OPTION 5	PLATING OPTION 4	PLATING OPTION 6
			ITEM NO.	ITEM NO.	ITEM NO.	ITEM NO.	ITEM NO.	ITEM NO.
04	(4.19)	(2.00)	79107-7001	79107-7051	X 79107-7126	79107-7201	79107-7251	X 79107-7326
06	(6.19)	(4.00)	79107-7002	79107-7052	X 79107-7127	79107-7202	79107-7252	X 79107-7327
08	(8.19)	(6.00)	79107-7003	79107-7053	X 79107-7128	79107-7203	79107-7253	X 79107-7328
10	(10.19)	(8.00)	79107-7004	79107-7054	X 79107-7129	79107-7204	79107-7254	X 79107-7329
12	(12.19)	(10.00)	79107-7005	79107-7055	79107-7130	79107-7205	79107-7255	79107-7330
14	(14.19)	(12.00)	79107-7006	79107-7056	X 79107-7131	79107-7206	79107-7256	X 79107-7331
16	(16.19)	(14.00)	79107-7007	79107-7057	X 79107-7132	79107-7207	79107-7257	X 79107-7332
18	(18.19)	(16.00)	79107-7008	79107-7058	X 79107-7133	79107-7208	79107-7258	X 79107-7333
20	(20.19)	(18.00)	79107-7009	79107-7059	X 79107-7134	79107-7209	79107-7259	X 79107-7334
22	(22.19)	(20.00)	79107-7010	79107-7060	X 79107-7135	79107-7210	79107-7260	X 79107-7335
24	(24.19)	(22.00)	79107-7011	79107-7061	X 79107-7136	79107-7211	79107-7261	X 79107-7336
26	(26.19)	(24.00)	79107-7012	79107-7062	X 79107-7137	79107-7212	79107-7262	X 79107-7337
28	(28.19)	(26.00)	79107-7013	79107-7063	X 79107-7138	79107-7213	79107-7263	X 79107-7338
30	(30.19)	(28.00)	79107-7014	79107-7064	X 79107-7139	79107-7214	79107-7264	X 79107-7339
32	(32.19)	(30.00)	79107-7015	79107-7065	X 79107-7140	79107-7215	79107-7265	X 79107-7340
34	(34.19)	(32.00)	79107-7016	79107-7066	X 79107-7141	79107-7216	79107-7266	X 79107-7341
36	(36.19)	(34.00)	79107-7017	79107-7067	X 79107-7142	79107-7217	79107-7267	X 79107-7342
38	(38.19)	(36.00)	79107-7018	79107-7068	X 79107-7143	79107-7218	79107-7268	X 79107-7343
40	(40.19)	(38.00)	79107-7019	79107-7069	X 79107-7144	79107-7219	79107-7269	X 79107-7344
42	(42.19)	(40.00)	79107-7020	79107-7070	X 79107-7145	79107-7220	79107-7270	X 79107-7345
44	(44.19)	(42.00)	79107-7021	79107-7071	X 79107-7146	79107-7221	79107-7271	X 79107-7346
46	(46.19)	(44.00)	79107-7022	79107-7072	X 79107-7147	79107-7222	79107-7272	X 79107-7347
48	(48.19)	(46.00)	79107-7023	79107-7073	X 79107-7148	79107-7223	79107-7273	X 79107-7348
50	(50.19)	(48.00)	79107-7024	79107-7074	X 79107-7149	79107-7224	79107-7274	X 79107-7349

X - DENOTES THE ITEM IS NOT AVAILABLE CURRENTLY.

CHANGE TOLERANCES EC NO: S2006-0225 DRWN: LOU AO 2005/09/09 CHKD: BOKOK 2005/09/09 APPR: PTL IM 2005/09/10	QUALITY SYMBOLS ▽=0 ▽=0	GENERAL TOLERANCES (UNLESS SPECIFIED) 4 PLACES ± --- ± --- 3 PLACES ± --- ± --- 2 PLACES ± 0.25 ± --- 1 PLACE ± 0.38 ± --- ANGULAR ±1/2°	DIMENSION STYLE MM ONLY DRAWN BY DATE AAB 1989/05/15 CHECKED BY DATE MJM 1989/05/15 APPROVED BY DATE WAZ 1989/05/15	SCALE NTS	DESIGN UNITS METRIC	THIRD ANGLE PROJECTION
	DRAFT WHERE APPLICABLE MUST REMAIN WITHIN DIMENSIONS			MATERIAL NO. SEE TABLE SIZE A3	DOCUMENT NO. SDA-79107-****	SHEET NO. 3 OF 4
	SALES DRAWING 2MM DUAL ROW VERTICAL RECEPTACLE T/H MOLEX INCORPORATED					
	THIS DRAWING CONTAINS INFORMATION THAT IS PROPRIETARY TO MOLEX INCORPORATED AND SHOULD NOT BE USED WITHOUT WRITTEN PERMISSION					

MOLDED VOID OPTION
ASSEMBLIES WITHOUT PEGS

CKT. SIZE	ASSEMBLY		VOID LOCATION(S) SEE SHEET 1 FOR CONVENTION		PLATING OPTION	DIM. "A"	DIM. "B"	P.C. TAIL DIM. "C"	PLATING OPTION
	ITEM NO.	ROW	CKT. NO.(s)						
24	79107-5001				2	(24.19)	(22.00)	(3.00)	TIN/LEAD
		ROW B	6						
10	79107-5002				2	(10.19)	(8.00)	(3.00)	
		ROW A	5						
26	79107-5003				2	(26.19)	(24.00)	(3.00)	
		ROW B	5						
24	79107-5101				5	(24.19)	(22.00)	(3.00)	TIN
		ROW B	6						
10	79107-5102				5	(10.19)	(8.00)	(3.00)	
		ROW A	5						
26	79107-5103				5	(26.19)	(24.00)	(3.00)	
		ROW B	5						

"X" - DENOTES THE ITEM IS NOT AVAILABLE CURRENTLY.

NOTES

1. TERMINALS WILL BE PRESENT IN VOIDED LOCATIONS HOWEVER, PIN WINDOWS WILL BE CLOSED.
2. VOIDS CANNOT BE PRESENT IN BOTH ROWS ON A CONNECTOR.

CHANGE TOLERANCES EC NO: S2006-0225 DRWN: LO/IAO CHKD: BOKOK APPR: PTL/IM	2005/09/09 2005/09/09 2005/09/10	QUALITY SYMBOLS ▽=0 ▽=0	GENERAL TOLERANCES (UNLESS SPECIFIED)		DIMENSION STYLE MM ONLY		SCALE NTS	DESIGN UNITS METRIC	THIRD ANGLE PROJECTION			
					mm	INCH	DRAWN BY AAB	DATE 1989/05/15	TITLE SALES DRAWING 2MM DUAL ROW VERTICAL RECEPTACLE T/H MOLEX INCORPORATED			
			4 PLACES	± ---	± ---	AAB	1989/05/15					
			3 PLACES	± ---	± ---	CHECKED BY MJM	DATE 1989/05/15	APPROVED BY WAZ		DATE 1989/05/15	DOCUMENT NO. SDA-79107-****	
2 PLACES	± 0.25	± ---	DRAFT WHERE APPLICABLE MUST REMAIN WITHIN DIMENSIONS		SEE TABLE							
1 PLACE	± 0.38	± ---										
		ANGULAR ±1/2°										