

**Product Features**

- 500 ~ 3000MHz
- GaAs E-pHEMT
- 41dBm Output IP3
- 20dB Gain at 900MHz
- 29dBm P1 dB
- SOT-89 SMT Package
- Single +5V Supply
- Pb Free / RoHS Standard

**Application**

- Cellular, CDMA, W-CDMA, Wimax Drive or Pre-drive Amplifier
- High Linearity Drive Amplifier

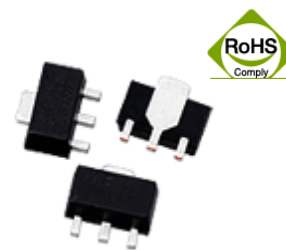

Package Type: SOT-89

**Description**

AE663 is a drive or pre-drive amplifier designed with GaAs E-pHEMT in a low cost SOT-89 package.

This E-pHEMT amplifier is designed as driver devices for infrastructure equipment in the 500~3000MHz Wireless technologies such as Cellular, GSM, PCS, CDMA, W-CDMA, Wibro, Bluetooth, Wimax.

**Specifications**

PARAMETER	Units	Min	Typ	Max
Frequency Range	MHz		500- 3000	
Gain ( $S_{21}$ )	dB	18	20	
Input Return Loss ( $S_{11}$ )	dB		-10	
Output Return Loss ( $S_{22}$ )	dB		-10	
Output 3 <sup>rd</sup> Order Intercept Point (OIP3)	dBm	38	41	
Output 1dB compression Point ( $P_{1dB}$ )	dBm	26.5	28.5	
Noise Figure	dB		2.5	3.5
DC Operating Current	mA	180	220	260
Supply Voltage	V		+5	

**Test Condition**

① 900MHz, Vdd= +5V at 25°C

② OIP3 is measured with two tones, at an output power of +15dBm/tone separated by 1MHz.

**Absolute Maximum Ratings**

PARAMETER	Rating	Remark
Operating Case Temperature (°C)	-40 ~ 85	
Storage Temperature (°C)	-50 ~ 125	
Drain-Source Voltage (V)	+7	

Application Circuit : 900MHz

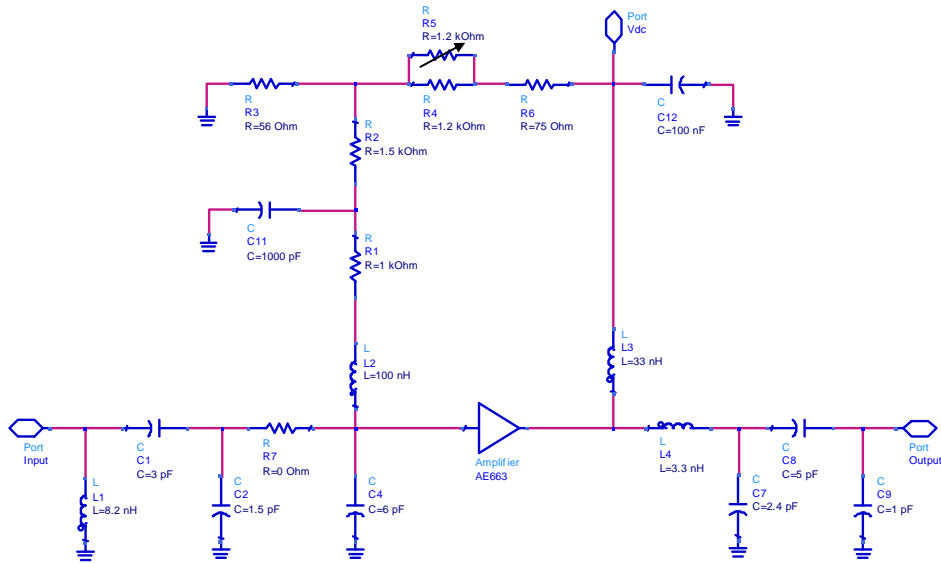

Cell, GSM, CDMA (824~960MHz) Performance Data ( $V_d=5V$ ,  $T_c=25^\circ C$ )

Items	Data	Remarks	Items	Data	Remarks
Gain	20.0 dB	824~960MHz	NF	3 dB	824~960MHz
OIP3	41 dBm	824~960MHz	P1dB	28 dBm	824~960MHz
CDMA 1FA	21.5 dBm	824~960MHz			

S-Parameter vs. Frequency

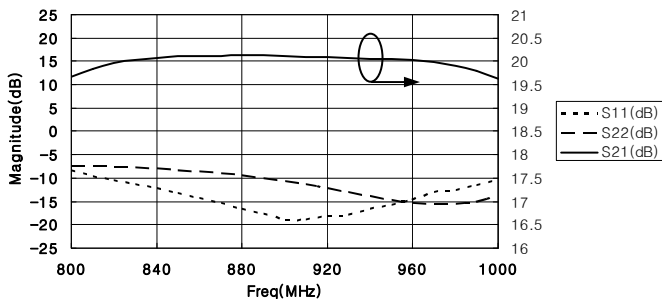

Noise Figure vs. Frequency

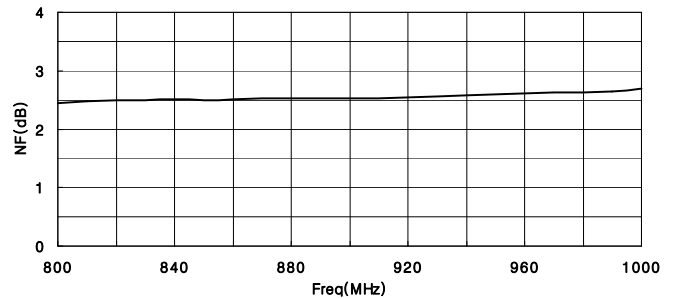

OIP3 vs. Frequency

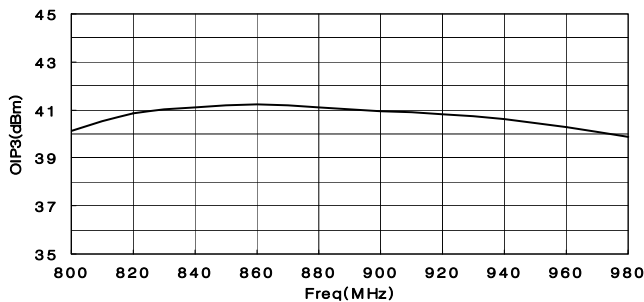

P1dB vs. Frequency

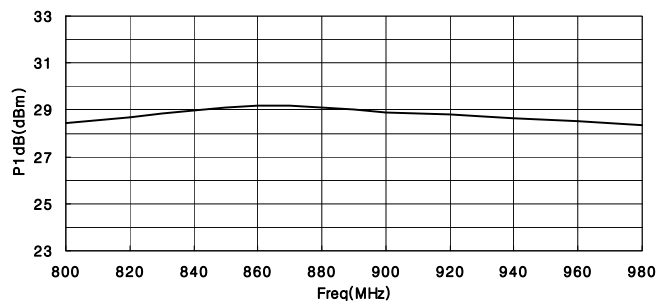

Application Circuit : 1800MHz

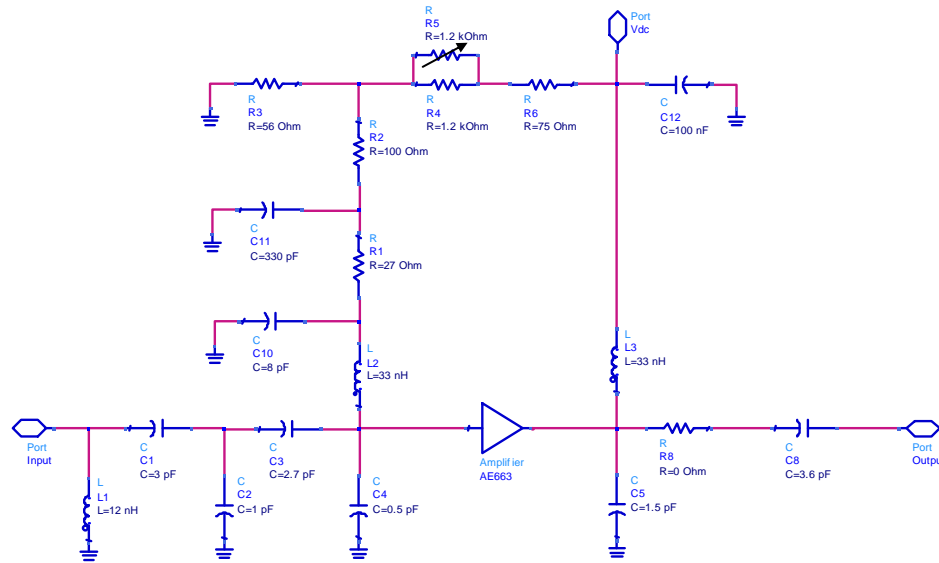

PCS, CDMA (1750~1870MHz) Performance Data ( $V_d=5V, T_c=25^\circ C$ )

Items	Data	Remarks	Items	Data	Remarks
Gain	14 dB	1750~1870MHz	NF	2.5 dB	1750~1870MHz
OIP3	42 dBm	1750~1870MHz	P1dB	28 dBm	1750~1870MHz
CDMA 1FA	19.5 dBm	1750~1870MHz			

S-Parameter vs. Frequency

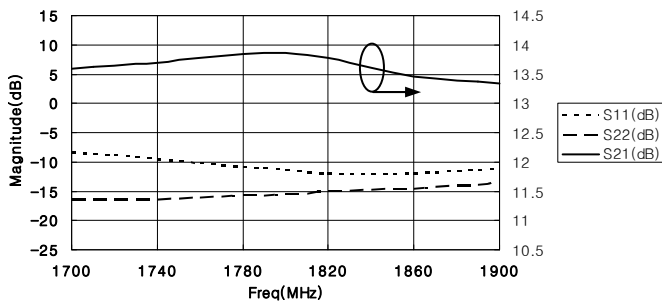

Noise Figure vs. Frequency

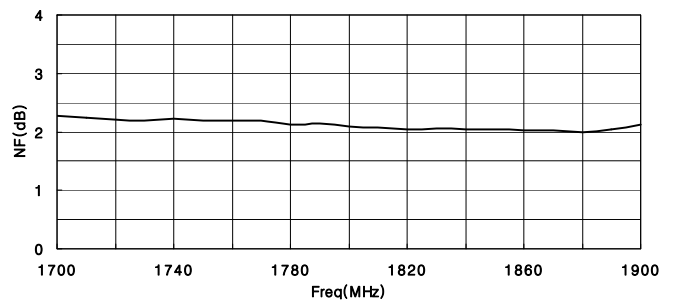

OIP3 vs. Frequency

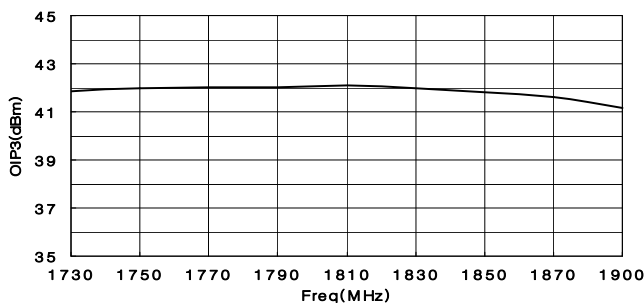

P1dB vs. Frequency

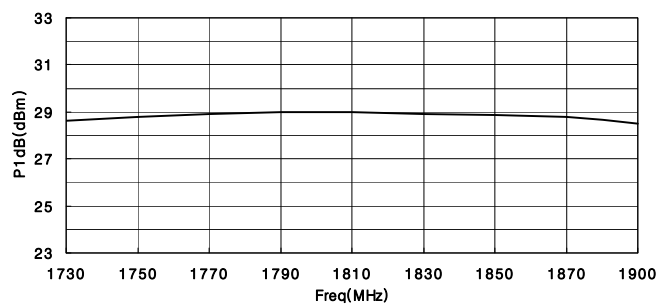

Application Circuit : 1900MHz

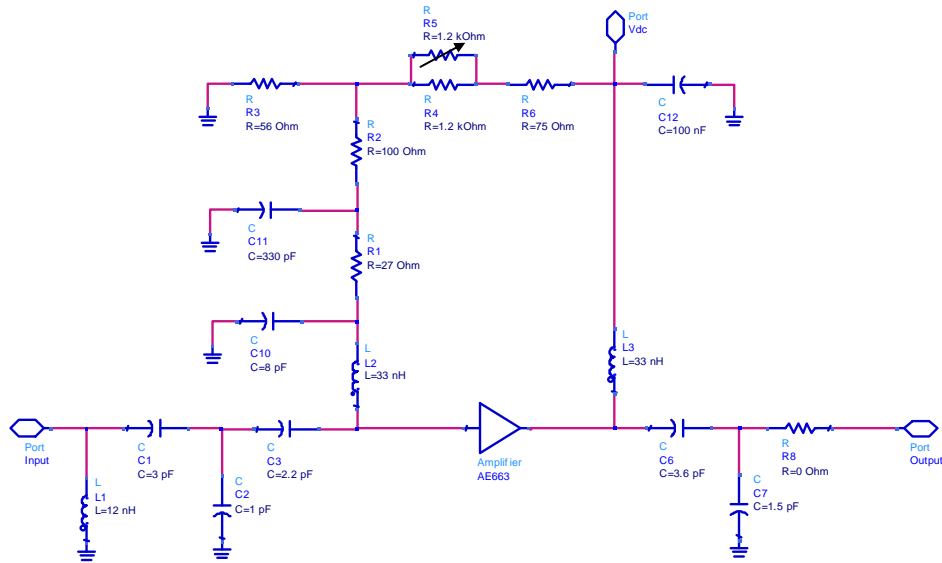

IMT, WCDMA (1920~1980MHz) Performance Data ( $V_d=5V, T_c=25^\circ C$ )

Items	Data	Remarks	Items	Data	Remarks
Gain	12.5 dB	1920~1980MHz	NF	2.5 dB	1920~1980MHz
OIP3	42 dBm	1920~1980MHz	P1dB	28 dBm	1920~1980MHz
WCDMA 1FA	19.5 dBm	1920~1980MHz	WCDMA 4FA	17.5 dBm	1920~1980MHz

S-Parameter vs. Frequency

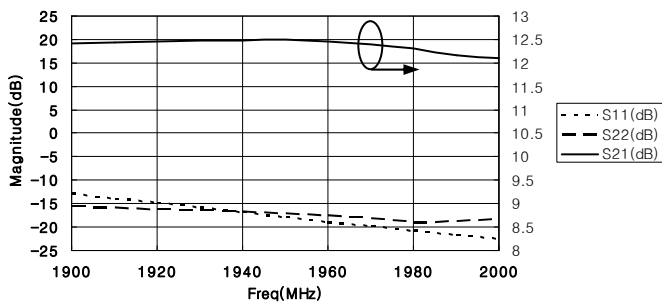

Noise Figure vs. Frequency

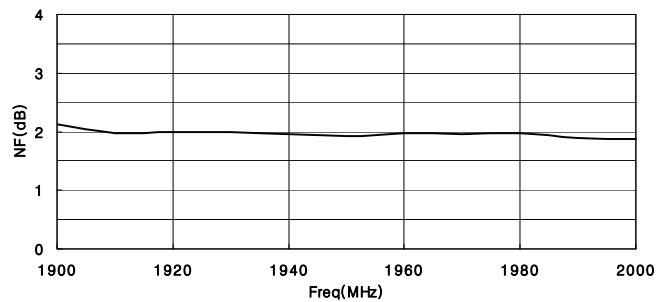

OIP3 vs. Frequency

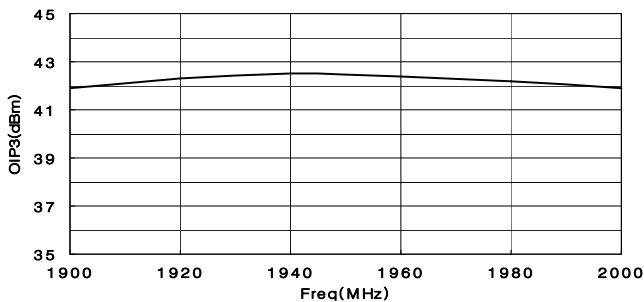

P1dB vs. Frequency

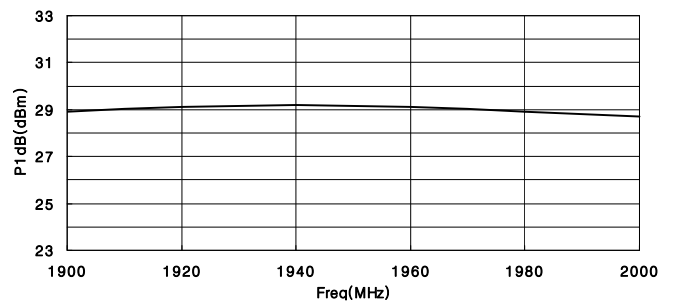

Application Circuit : 2100MHz

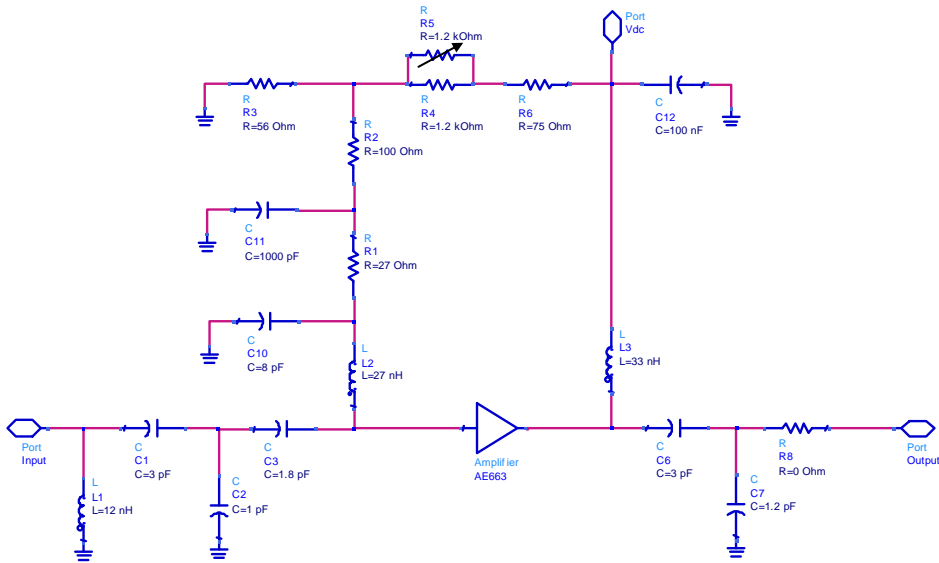

IMT, WCDMA (2110~2170MHz) Performance Data ( $V_d=5V, T_c=25^\circ C$ )

Items	Data	Remarks	Items	Data	Remarks
Gain	12 dB	2110~2170MHz	NF	2.5 dB	2110~2170MHz
OIP3	42 dBm	2110~2170MHz	P1dB	28 dBm	2110~2170MHz
WCDMA 1FA	19.5 dBm	2110~2170MHz	WCDMA 4FA	17.5 dBm	2110~2170MHz

S-Parameter vs. Frequency

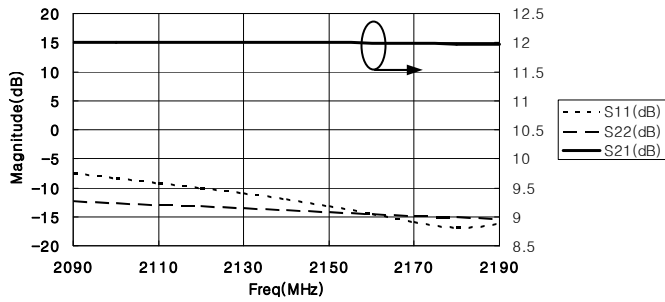

Noise Figure vs. Frequency

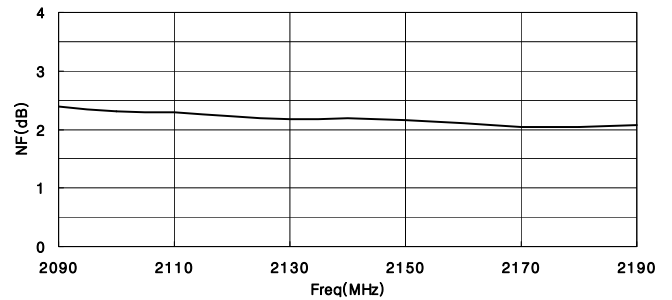

OIP3 vs. Frequency

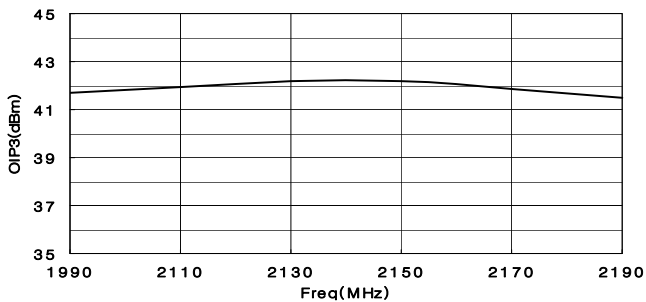

P1dB vs. Frequency

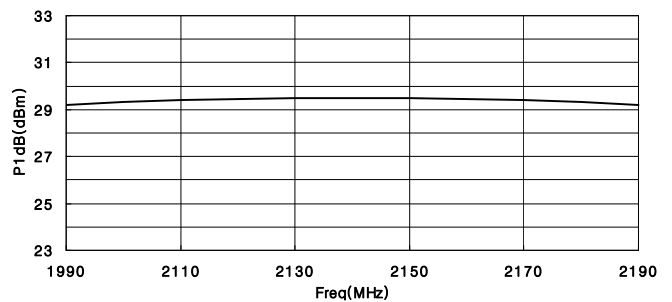

## Application Circuit : 2400MHz

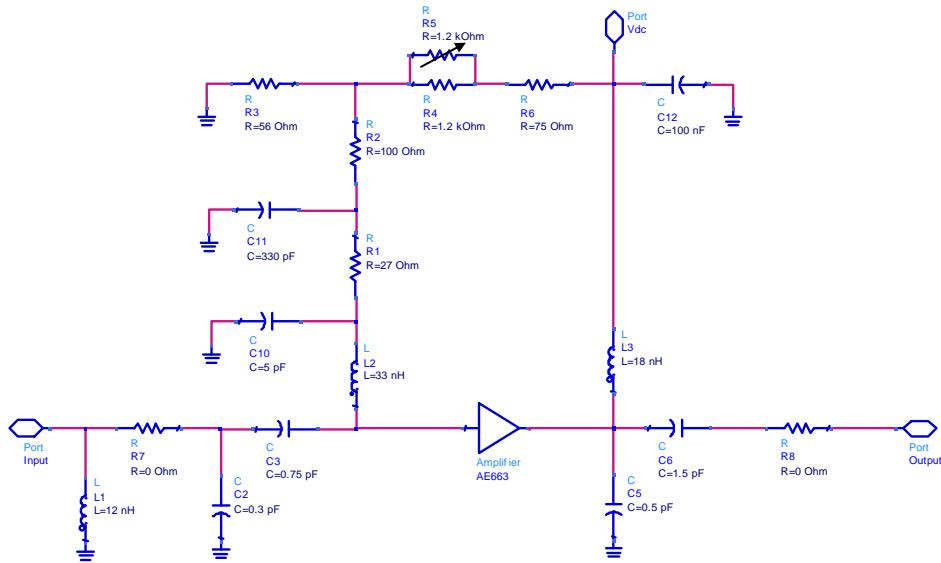

### Wibro, Bluetooth, OFDM (2300~2500MHz) Performance Data ( $V_d=5V, T_c=25^\circ C$ )

Items	Data	Remarks	Items	Data	Remarks
Gain	11.5 dB	2300~2500MHz	NF	2.5 dB	2300~2500MHz
OIP3	42 dBm	2300~2500MHz	P1dB	28.5 dBm	2300~2500MHz

S-Parameter vs. Frequency

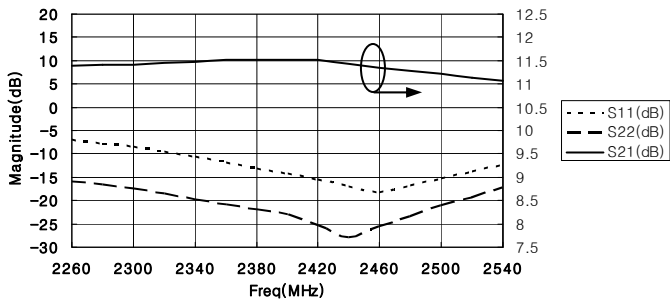

Noise Figure vs. Frequency

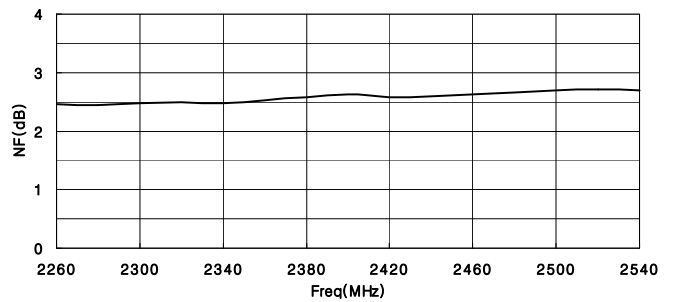

OIP3 vs. Frequency

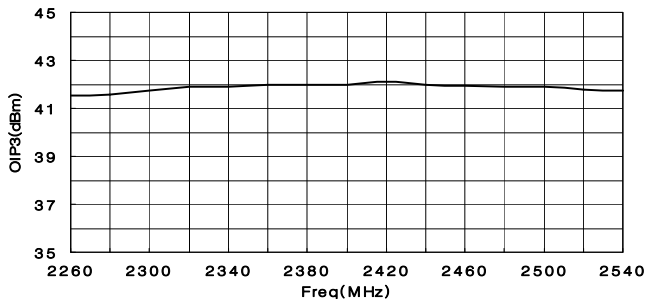

P1dB vs. Frequency

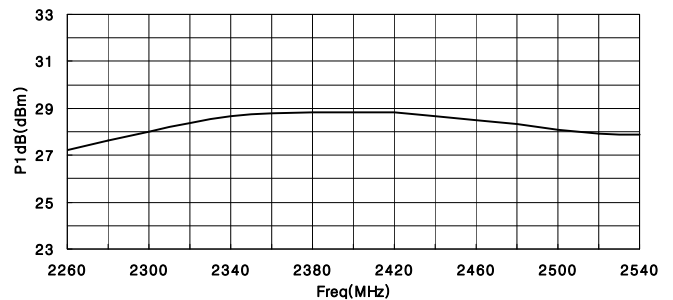

## Application Circuit : 2700MHz

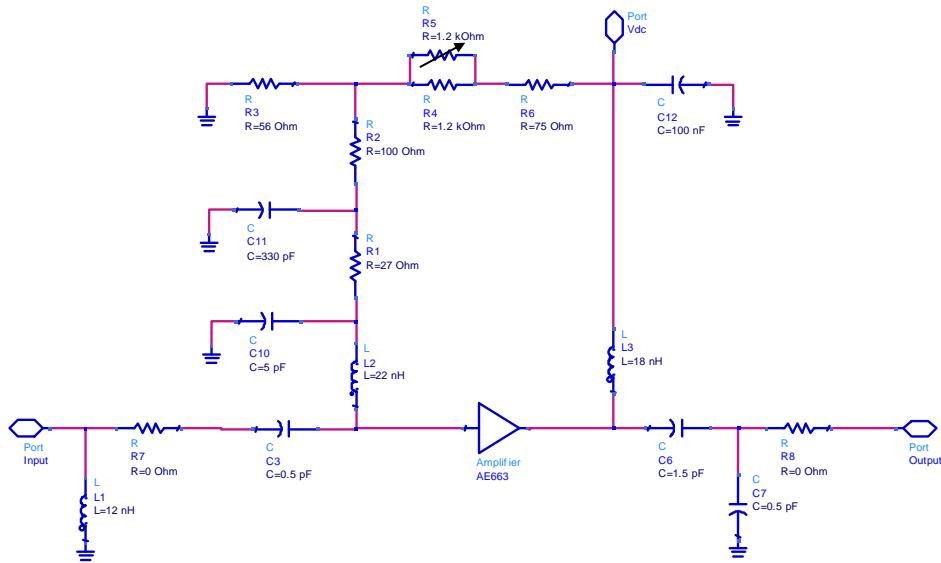

Wimax, OFDM (2600~2800MHz) Performance Data ( $V_d=5V$ ,  $T_c=25^\circ C$ )

Items	Data	Remarks	Items	Data	Remarks
Gain	10.5 dB	2600~2800MHz	NF	3 dB	2600~2800MHz
OIP3	42 dBm	2600~2800MHz	P1dB	28.5 dBm	2600~2800MHz

S-Parameter vs. Frequency

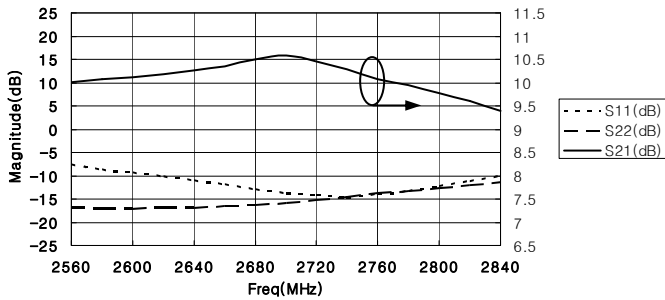

Noise Figure vs. Frequency

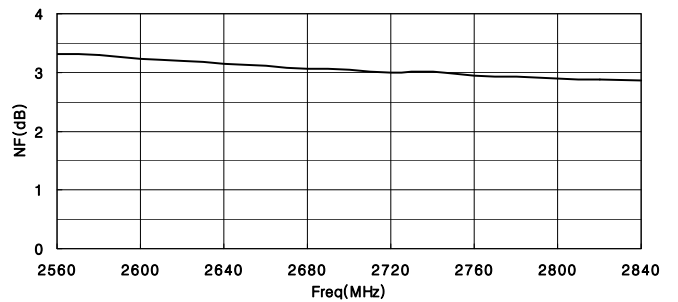

OIP3 vs. Frequency

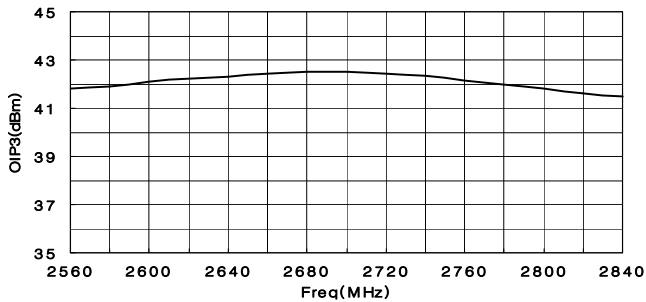

P1dB vs. Frequency

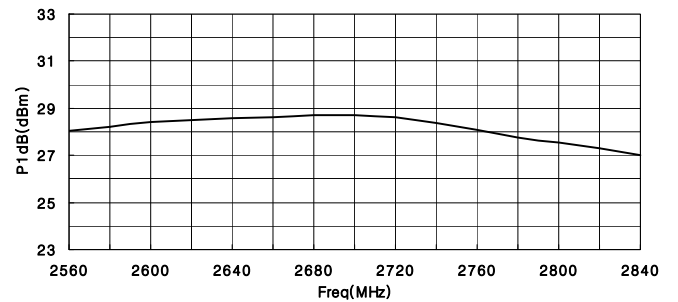

## Package Dimensions (Type: SOT-89)

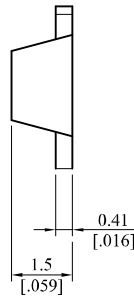
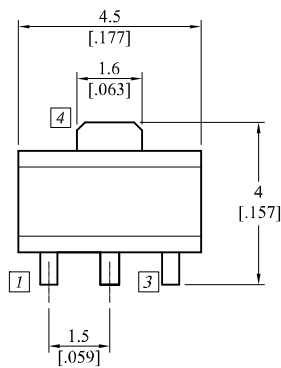

Unit : mm  
Tolerance : ± 0.2 / 0.08

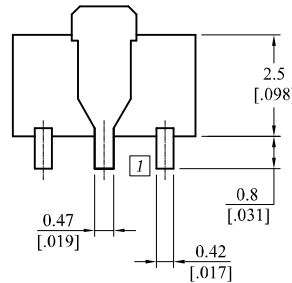

## Recommended Pattern

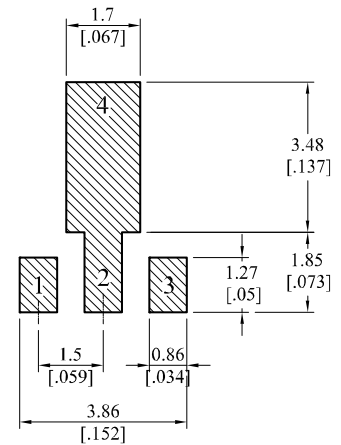

Pin No	Function
1	Input
2	Ground
3	Output, Vd
4	Ground

! ESD sensitive

Observe precautions for handling, testing and

## PCB Evaluation Board Layout Pattern

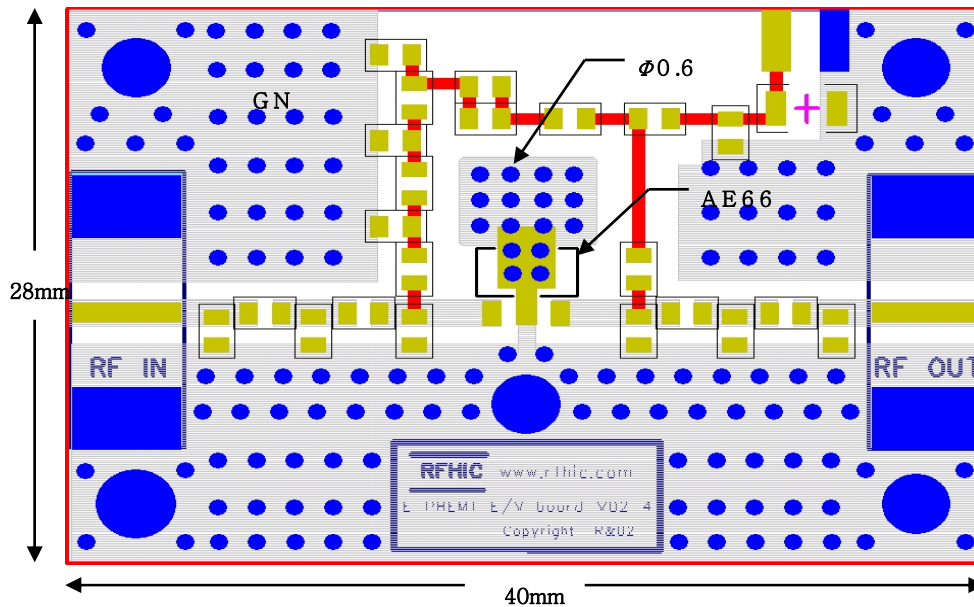

PCB material (FR4), PCB thickness (0.8t), Via hole ( $\phi 0.6$ ), Via space of package bottom (1.3mm)

RFHIC Corporation (RFHIC) reserves the right to make changes to any products herein or to discontinue any product at any time without notice. RFHIC do not assume any liability for the suitability of its products for any particular purpose, and disclaims any and all liability, including without limitation consequential or incidental damages. The product specifications herein expressed have been carefully checked and are assumed to be reliable. However, RFHIC disclaims liability for inaccuracies and strongly recommends buyers to verify that the information they are using is current before placing purchase orders. RFHIC products are not intended for use in life support equipment or application where malfunction of the product can be expected to result in personal injury or death. Buyer uses or sells such products for any such unintended or unauthorized application, buyer shall indemnify, protect and hold RFHIC and its directors, officers, stockholders, employees, representatives and distributors harmless against any and all claims arising out of such use. RFHIC's liability under or arising out of damages, claims of whatsoever kind and nature which RFHIC products could cause shall be limited in amount to the net purchase price of the products sold to buyer by RFHIC.