

HC257 QUAD 2 CHANNEL MULTIPLEXER (3-STATE) HC258 QUAD 2 CHANNEL MULTIPLEXER (3-STATE, INVERTING)

- HIGH SPEED
 $t_{PD} = 10 \text{ ns (TYP.) at } V_{CC} = 5 \text{ V}$
- LOW POWER DISSIPATION
 $I_{CC} = 4 \mu\text{A (MAX.) at } T_A = 25 \text{ }^\circ\text{C}$
- HIGH NOISE IMMUNITY
 $V_{NIH} = V_{NIL} = 28 \% V_{CC} \text{ (MIN.)}$
- OUTPUT DRIVE CAPABILITY
 15 LSTTL LOADS
- SYMMETRICAL OUTPUT IMPEDANCE
 $|I_{OH}| = I_{OL} = 6 \text{ mA (MIN.)}$
- BALANCED PROPAGATION DELAYS
 $t_{PLH} = t_{PHL}$
- WIDE OPERATING VOLTAGE RANGE
 $V_{CC} \text{ (OPR.)} = 2 \text{ V to } 6 \text{ V}$
- PIN AND FUNCTION COMPATIBLE
 WITH 54/74LS257/258

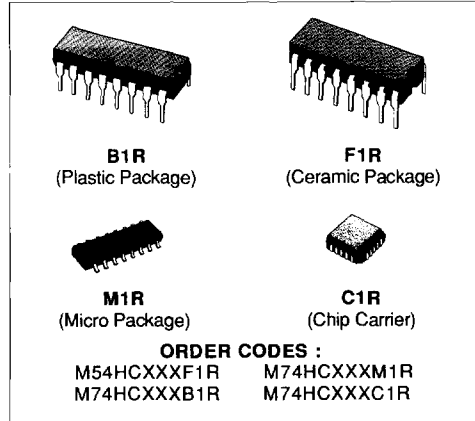

DESCRIPTION

The M54/74HC257 and the M54/74HC258 are high speed CMOS MULTIPLEXERS fabricated with silicon gate C²MOS technology.

They have the same high speed performance of LSTTL combined with true CMOS low power consumption.

These IC's are composed of an independent 2-channel multiplexer with common SELECT and ENABLE INPUT.

The M54/74HC258 is an inverting multiplexer while the M54/74HC257 is a non-inverting multiplexer. When the ENABLE INPUT is held "High", outputs of both IC's become high-impedance state. If SELECT INPUT is held "Low", "A" data is selected, when SELECT INPUT is high "H", "B" data is chosen.

All inputs are equipped with protection circuits against static discharge and transient excess voltage.

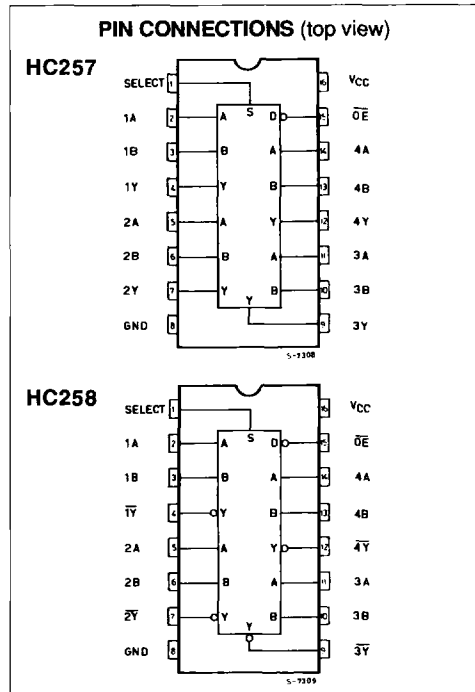

INPUT AND OUTPUT EQUIVALENT CIRCUIT

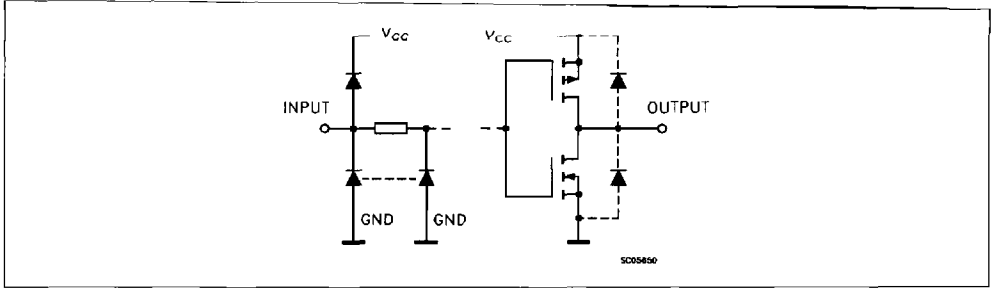

CHIP CARRIER

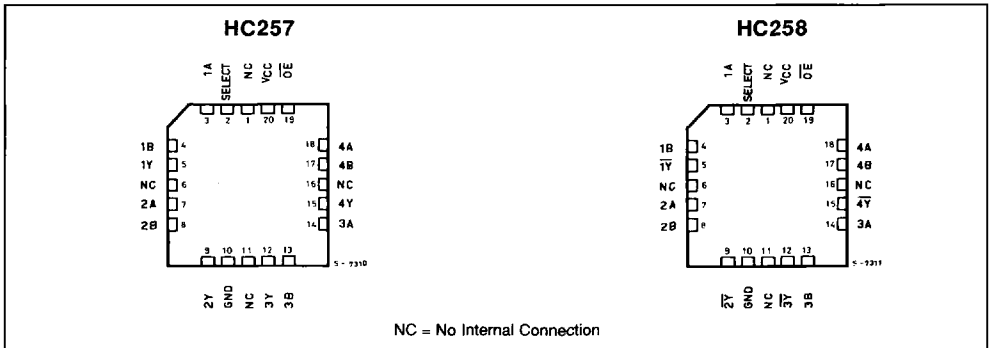

PIN DESCRIPTION (HC257)

PIN No	SYMBOL	NAME AND FUNCTION
1	SELECT	Common Data Select Input
2, 5, 14, 11	1A to 4A	Data Input From Source A
3, 6, 13, 10	1B to 4B	Data Inputs from Source B
4, 7, 12, 9	1Y to 4Y	3 State Multiplexer Outputs
15	OE	3 State Output Enable Inputs (Active LOW)
8	GND	Ground (0V)
16	Vcc	Positive Supply Voltage

PIN DESCRIPTION (HC258)

PIN No	SYMBOL	NAME AND FUNCTION
1	SELECT	Common Data Select Input
2, 5, 14, 11	1A to 4A	Data Input From Source A
3, 6, 13, 10	1B to 4B	Data Inputs from Source B
4, 7, 12, 9	1Y to 4Y	3 State Multiplexer Outputs
15	OE	3 State Output Enable Inputs (Active LOW)
8	GND	Ground (0V)
16	Vcc	Positive Supply Voltage

IEC LOGIC SYMBOL

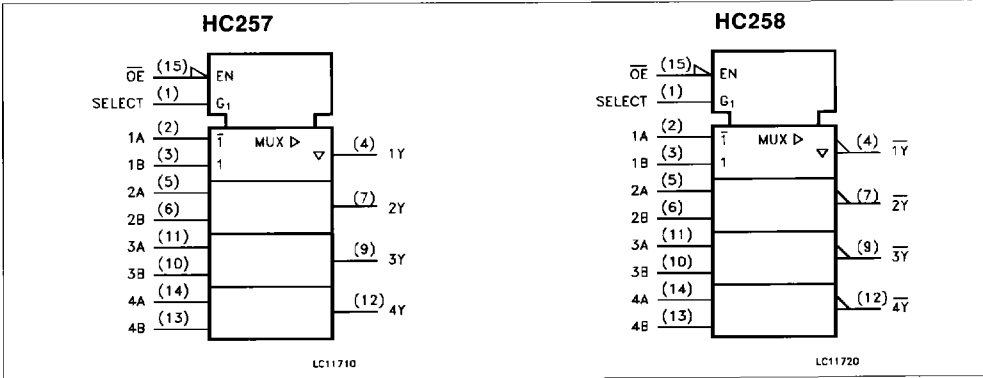

LOGIC DIAGRAM

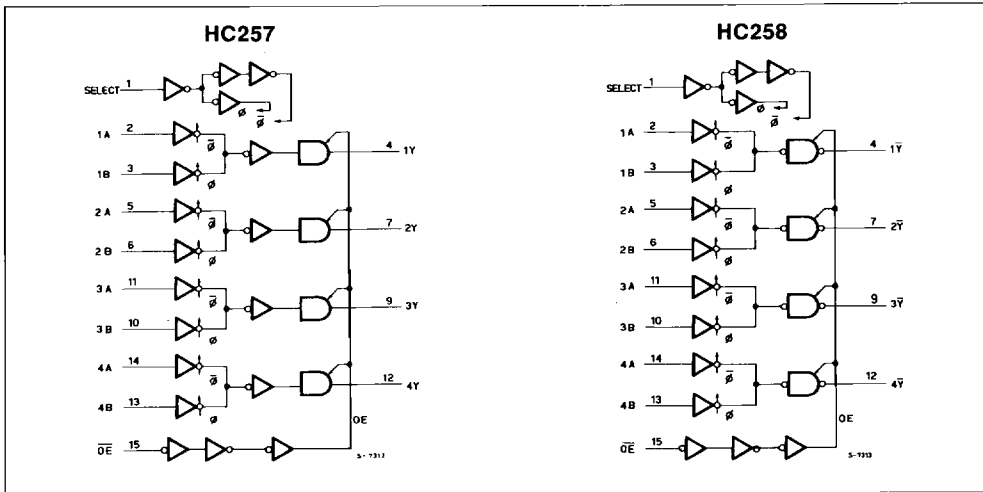

TRUTH TABLE

INPUTS				OUTPUTS	
OE	SELECT	A	B	Y (257)	\bar{Y} (258)
H	X	X	X	Z	Z
L	L	L	X	L	H
L	L	H	X	H	L
L	H	X	L	L	H
L	H	X	H	H	L

X = DONT CARE Z = HIGH IMPEDANCE

ABSOLUTE MAXIMUM RATINGS

Symbol	Parameter	Value	Unit
V _{CC}	Supply Voltage	-0.5 to +7	V
V _I	DC Input Voltage	-0.5 to V _{CC} + 0.5	V
V _O	DC Output Voltage	-0.5 to V _{CC} + 0.5	V
I _{IK}	DC Input Diode Current	± 20	mA
I _{OK}	DC Output Diode Current	± 20	mA
I _O	DC Output Source Sink Current Per Output Pin	± 35	mA
I _{CC} or I _{GND}	DC V _{CC} or Ground Current	± 70	mA
P _D	Power Dissipation	500 (*)	mW
T _{stg}	Storage Temperature	-65 to +150	°C
T _L	Lead Temperature (10 sec)	300	°C

Absolute Maximum Ratings are those values beyond which damage to the device may occur. Functional operation under these condition is not implied.

(*) 500 mW: = 65 °C derate to 300 mW by 10mW/°C: 65 °C to 85 °C

RECOMMENDED OPERATING CONDITIONS

Symbol	Parameter	Value	Unit	
V _{CC}	Supply Voltage	2 to 6	V	
V _I	Input Voltage	0 to V _{CC}	V	
V _O	Output Voltage	0 to V _{CC}	V	
T _{op}	Operating Temperature: M54HC Series M74HC Series	-55 to +125 -40 to +85	°C °C	
t _r , t _f	Input Rise and Fall Time	V _{CC} = 2 V V _{CC} = 4.5 V V _{CC} = 6 V	0 to 1000 0 to 500 0 to 400	ns

DC SPECIFICATIONS

Symbol	Parameter	Test Conditions		Value						Unit		
		V _{CC} (V)		T _A = 25 °C 54HC and 74HC			-40 to 85 °C 74HC		-55 to 125 °C 54HC			
				Min.	Typ.	Max.	Min.	Max.	Min.		Max.	
V _{IH}	High Level Input Voltage	2.0		1.5			1.5		1.5		V	
		4.5		3.15			3.15		3.15			
		6.0		4.2			4.2		4.2			
V _{IL}	Low Level Input Voltage	2.0				0.5		0.5		0.5	V	
		4.5				1.35		1.35		1.35		
		6.0				1.8		1.8		1.8		
V _{OH}	High Level Output Voltage	2.0	V _I = V _{IH} or V _{IL}	I _O = -20 μA	1.9	2.0		1.9		1.9	V	
		4.5			4.4	4.5		4.4		4.4		
		6.0	I _O = -6.0 mA I _O = -7.8 mA	5.9	6.0		5.9		5.9			
		4.5		4.18	4.31		4.13		4.10			
		6.0		5.68	5.8		5.63		5.60			
V _{OL}	Low Level Output Voltage	2.0	V _I = V _{IH} or V _{IL}	I _O = 20 μA		0.0	0.1		0.1		V	
		4.5				0.0	0.1		0.1			0.1
		6.0	I _O = 6.0 mA I _O = 7.8 mA		0.0	0.1		0.1		0.1		
		4.5			0.17	0.26		0.33		0.40		
		6.0			0.18	0.26		0.33		0.40		
I _I	Input Leakage Current	6.0	V _I = V _{CC} or GND				±0.1		±1		±1	μA
I _{OZ}	Output Leakage Current	6.0	V _I = V _{IH} or V _{IL} V _O = V _{CC} or GND				±0.5		±5		±10	μA
I _{CC}	Quiescent Supply Current	6.0	V _I = V _{CC} or GND				4		40		80	μA

AC ELECTRICAL CHARACTERISTICS (C_L = 50 pF, Input t_r = t_f = 6 ns)

Symbol	Parameter	Test Conditions		Value						Unit			
		V _{CC} (V)	C _L (pF)	T _A = 25 °C			-40 to 85 °C		-55 to 125 °C				
				54HC and 74HC			74HC		54HC				
				Min.	Typ.	Max.	Min.	Max.	Min.	Max.			
t _{TLH} t _{THL}	Output Transition Time	2.0	50			25	60		75		90	ns	
		4.5				7	12		15		19		
		6.0				6	10		13		15		
t _{PLH} t _{PHL}	Propagation Delay Time (A, B - Y)	2.0	50			45	100		125		150	ns	
		4.5				13	20		25		30		
		6.0				11	17		21		26		
		2.0	150			62	140		175		210	ns	
		4.5				18	28		35		42		
		6.0			15	24		30		36			
t _{PLH} t _{PHL}	Propagation Delay Time (SELECT - Y)	2.0	50			45	100		125		150	ns	
		4.5				13	20		25		30		
		6.0				11	17		21		26		
		2.0	150			62	140		175		210	ns	
		4.5				18	28		35		42		
		6.0			15	24		30		36			
t _{PZL} t _{PZH}	Output Enable Time	2.0	50	R _L = 1 KΩ		40	110		140		165	ns	
		4.5				12	22		28		33		
		6.0				10	19		24		28		
		2.0	150	R _L = 1 KΩ		57	150		190		225	ns	
		4.5				17	30		38		45		
		6.0			14	26		32		38			
t _{PLZ} t _{PHZ}	Output Disable Time	2.0	50	R _L = 1 KΩ		28	140		175		210	ns	
		4.5				14	28		35		42		
		6.0				13	24		30		36		
C _{IN}	Input Capacitance					5	10		10		10	pF	
C _{OUT}	Output Capacitance					10						pF	
C _{PD} (*)	Power Dissipation Capacitance					47						pF	

(*) C_{PD} is defined as the value of the IC's internal equivalent capacitance which is calculated from the operating current consumption without load. (Refer to Test Circuit). Average operating current can be obtained by the following equation. I_{CC(OPR)} = C_{PD} • V_{CC} • f_N + I_{CC4} (per Channel)

SWITCHING CHARACTERISTICS TEST WAVEFORM

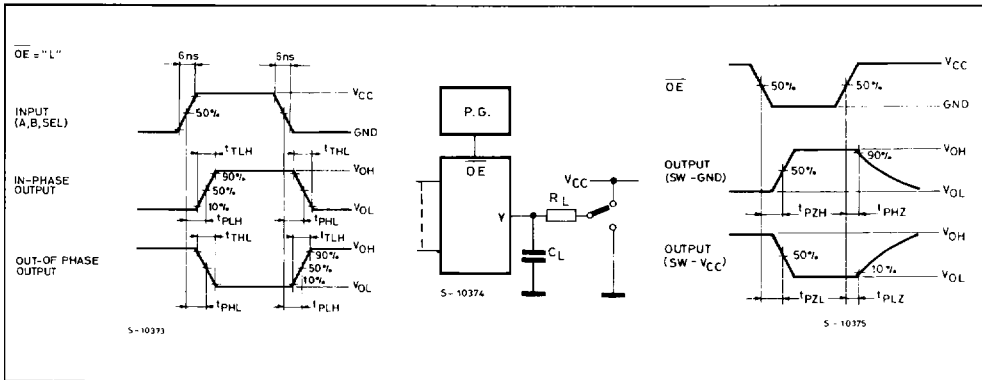
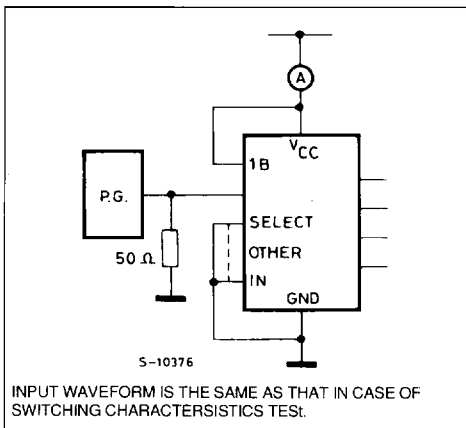
TEST CIRCUIT I_{CC} (Opr.)C_{PD} CALCULATION

C_{PD} is to be calculated with the following formula by using the measured value of I_{CC} (opr.) in the test circuit opposite.

$$C_{PD} = \frac{I_{CC} (opr.)}{f_{IN} \times V_{CC}}$$