



## 54AC/74AC174 • 54ACT/74ACT174 Hex D Flip-Flop with Master Reset

### General Description

The 'AC/'ACT174 is a high-speed hex D flip-flop. The device is used primarily as a 6-bit edge-triggered storage register. The information on the D inputs is transferred to storage during the LOW-to-HIGH clock transition. The device has a Master Reset to simultaneously clear all flip-flops.

### Features

- $I_{CC}$  reduced by 50%
- Outputs source/sink 24 mA
- 'ACT174 has TTL-compatible inputs
- Standard Military Drawing (SMD)
  - 'AC174: 5962-87626
  - 'ACT174: 5962-87757

**Ordering Code:** See Section 8

### Logic Symbols

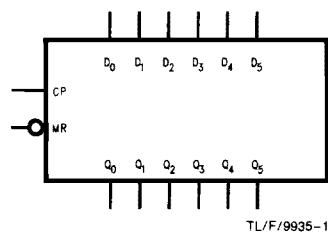

Pin Names	Description
D <sub>0</sub> -D <sub>5</sub>	Data Inputs
CP	Clock Pulse Input
MR	Master Reset Input
Q <sub>0</sub> -Q <sub>5</sub>	Outputs

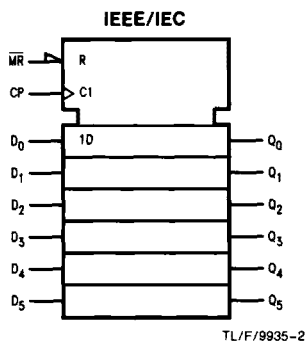

### Connection Diagrams

#### Pin Assignment for DIP, Flatpak and SOIC

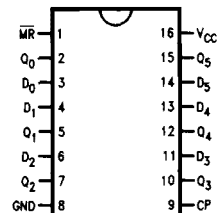

#### Pin Assignment for LCC

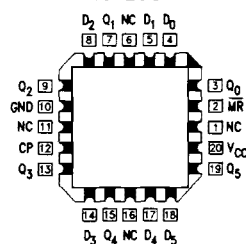

## Functional Description

The 'AC/'ACT174 consists of six edge-triggered D flip-flops with individual D inputs and Q outputs. The Clock (CP) and Master Reset ( $\overline{MR}$ ) are common to all flip-flops. Each D input's state is transferred to the corresponding flip-flop's output following the LOW-to-HIGH Clock (CP) transition. A LOW input to the Master Reset ( $\overline{MR}$ ) will force all outputs LOW independent of Clock or Data inputs. The 'AC/'ACT174 is useful for applications where the true output only is required and the Clock and Master Reset are common to all storage elements.

## Truth Table

Inputs			Output
$\overline{MR}$	CP	D	Q
L	X	X	L
H	↗	H	H
H	↘	L	L
H	L	X	Q

H = HIGH Voltage Level  
 L = LOW Voltage Level  
 X = Immaterial  
 ↗ = LOW-to-HIGH Transition

## Logic Diagram

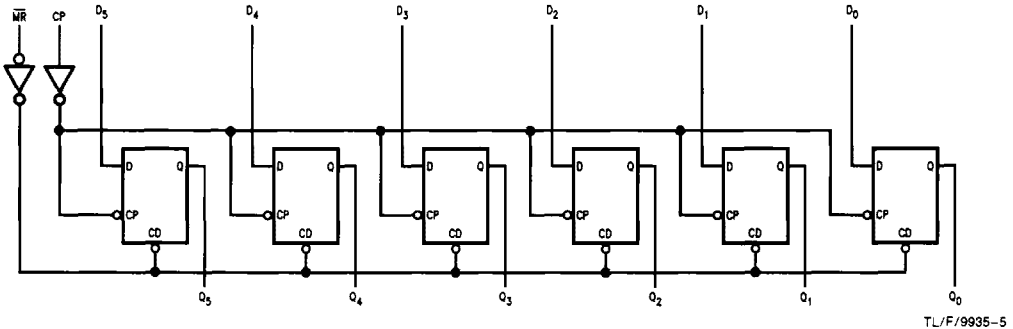

Please note that this diagram is provided only for the understanding of logic operations and should not be used to estimate propagation delays.

TL/F/9935-5

## Absolute Maximum Ratings (Note 1)

If Military/Aerospace specified devices are required, please contact the National Semiconductor Sales Office/Distributors for availability and specifications.

Supply Voltage ( $V_{CC}$ )	-0.5V to +7.0V
DC Input Diode Current ( $I_{IK}$ )	
$V_I = -0.5V$	-20 mA
$V_I = V_{CC} + 0.5V$	+20 mA
DC Input Voltage ( $V_I$ )	-0.5V to $V_{CC} + 0.5V$
DC Output Diode Current ( $I_{OK}$ )	
$V_O = -0.5V$	-20 mA
$V_O = V_{CC} + 0.5V$	+20 mA
DC Output Voltage ( $V_O$ )	-0.5V to $V_{CC} + 0.5V$
DC Output Source or Sink Current ( $I_O$ )	$\pm 50$ mA
DC $V_{CC}$ or Ground Current per Output Pin ( $I_{CC}$ or $I_{GND}$ )	$\pm 50$ mA
Storage Temperature ( $T_{STG}$ )	-65°C to +150°C
Junction Temperature ( $T_J$ )	
CDIP	175°C
PDIP	140°C

Note 1: Absolute maximum ratings are those values beyond which damage to the device may occur. The databook specifications should be met, without exception, to ensure that the system design is reliable over its power supply, temperature, and output/input loading variables. National does not recommend operation of FACT™ circuits outside databook specifications.

## Recommended Operating Conditions

Supply Voltage ( $V_{CC}$ )		2.0V to 6.0V
'AC		4.5V to 5.5V
'ACT		
Input Voltage ( $V_I$ )		0V to $V_{CC}$
Output Voltage ( $V_O$ )		0V to $V_{CC}$
Operating Temperature ( $T_A$ )		
74AC/ACT		-40°C to +85°C
54AC/ACT		-55°C to +125°C
Minimum Input Edge Rate ( $\Delta V/\Delta t$ )		
'AC Devices		
$V_{IN}$ from 30% to 70% of $V_{CC}$		
$V_{CC}$ @ 3.3V, 4.5V, 5.5V		125 mV/ns
Minimum Input Edge Rate ( $\Delta V/\Delta t$ )		
'ACT Devices		
$V_{IN}$ from 0.8V to 2.0V		
$V_{CC}$ @ 4.5V, 5.5V		125 mV/ns

## DC Characteristics for 'AC Family Devices

Symbol	Parameter	$V_{CC}$ (V)	74AC		54AC		74AC		Units	Conditions
			$T_A = +25^\circ\text{C}$		$T_A = -55^\circ\text{C to } +125^\circ\text{C}$		$T_A = -40^\circ\text{C to } +85^\circ\text{C}$			
			Typ	Guaranteed Limits						
$V_{IH}$	Minimum High Level Input Voltage	3.0	1.5	2.1	2.1	2.1	V	$V_{OUT} = 0.1V$ or $V_{CC} - 0.1V$		
		4.5	2.25	3.15	3.15	3.15				
		5.5	2.75	3.85	3.85	3.85				
$V_{IL}$	Maximum Low Level Input Voltage	3.0	1.5	0.9	0.9	0.9	V	$V_{OUT} = 0.1V$ or $V_{CC} - 0.1V$		
		4.5	2.25	1.35	1.35	1.35				
		5.5	2.75	1.65	1.65	1.65				
$V_{OH}$	Minimum High Level Output Voltage	3.0	2.99	2.9	2.9	2.9	V	$I_{OUT} = -50 \mu\text{A}$		
		4.5	4.49	4.4	4.4	4.4				
		5.5	5.49	5.4	5.4	5.4				
$V_{OL}$	Maximum Low Level Output Voltage	3.0		2.56	2.4	2.46	V	* $V_{IN} = V_{IL}$ or $V_{IH}$ -12 mA		
		4.5		3.86	3.7	3.76				
		5.5		4.86	4.7	4.76				
$V_{OL}$	Maximum Low Level Output Voltage	3.0	0.002	0.1	0.1	0.1	V	$I_{OUT} = 50 \mu\text{A}$		
		4.5	0.001	0.1	0.1	0.1				
		5.5	0.001	0.1	0.1	0.1				
$V_{OL}$	Maximum Low Level Output Voltage	3.0		0.36	0.50	0.44	V	* $V_{IN} = V_{IL}$ or $V_{IH}$ 12 mA		
		4.5		0.36	0.50	0.44				
		5.5		0.36	0.50	0.44				
$I_{IN}$	Maximum Input Leakage Current	5.5		$\pm 0.1$	$\pm 1.0$	$\pm 1.0$	$\mu\text{A}$	$V_I = V_{CC}, \text{GND}$		

\*All outputs loaded; thresholds on input associated with output under test.

## DC Characteristics for 'AC Family Devices (Continued)

Symbol	Parameter	V <sub>CC</sub> (V)	74AC		54AC	74AC	Units	Conditions
			T <sub>A</sub> = +25°C		T <sub>A</sub> = -55°C to +125°C	T <sub>A</sub> = -40°C to +85°C		
			Typ	Guaranteed Limits				
I <sub>OLD</sub>	†Minimum Dynamic Output Current	5.5			50	75	mA	V <sub>OLD</sub> = 1.65V Max
I <sub>OHD</sub>		5.5			-50	-75	mA	V <sub>OHD</sub> = 3.85V Min
I <sub>CC</sub>	Maximum Quiescent Supply Current	5.5		4.0	80.0	40.0	μA	V <sub>IN</sub> = V <sub>CC</sub> or GND

\*All outputs loaded; thresholds on input associated with output under test.

†Maximum test duration 2.0 ms, one output loaded at a time.

Note: I<sub>IN</sub> and I<sub>CC</sub> @ 3.0V are guaranteed to be less than or equal to the respective limit @ 5.5V V<sub>CC</sub>.

I<sub>CC</sub> for 54AC @ 25°C is identical to 74AC @ 25°C.

## DC Characteristics for 'ACT Family Devices

Symbol	Parameter	V <sub>CC</sub> (V)	74ACT		54ACT	74ACT	Units	Conditions	
			T <sub>A</sub> = +25°C		T <sub>A</sub> = -55°C to +125°C	T <sub>A</sub> = -40°C to +85°C			
			Typ	Guaranteed Limits					
V <sub>IH</sub>	Minimum High Level Input Voltage	4.5	1.5	2.0	2.0	2.0	V	V <sub>OUT</sub> = 0.1V or V <sub>CC</sub> - 0.1V	
		5.5	1.5	2.0	2.0	2.0			
V <sub>IL</sub>	Maximum Low Level Input Voltage	4.5	1.5	0.8	0.8	0.8	V	V <sub>OUT</sub> = 0.1V or V <sub>CC</sub> - 0.1V	
		5.5	1.5	0.8	0.8	0.8			
V <sub>OH</sub>	Minimum High Level Output Voltage	4.5	4.49	4.4	4.4	4.4	V	I <sub>OUT</sub> = -50 μA	
		5.5	5.49	5.4	5.4	5.4			
			4.5		3.86	3.70	3.76	V	*V <sub>IN</sub> = V <sub>IL</sub> or V <sub>IH</sub> -24 mA I <sub>OH</sub> -24 mA
			5.5		4.86	4.70	4.76		
V <sub>OL</sub>	Maximum Low Level Output Voltage	4.5	0.001	0.1	0.1	0.1	V	I <sub>OUT</sub> = 50 μA	
		5.5	0.001	0.1	0.1	0.1			
			4.5		0.36	0.50	0.44	V	*V <sub>IN</sub> = V <sub>IL</sub> or V <sub>IH</sub> 24 mA I <sub>OL</sub> 24 mA
			5.5		0.36	0.50	0.44		
I <sub>IN</sub>	Maximum Input Leakage Current	5.5		±0.1	±1.0	±1.0	μA	V <sub>I</sub> = V <sub>CC</sub> , GND	
I <sub>CC</sub> T	Maximum I <sub>CC</sub> /Input	5.5	0.6		1.6	1.5	mA	V <sub>I</sub> = V <sub>CC</sub> - 2.1V	
I <sub>OLD</sub>	†Minimum Dynamic Output Current	5.5			50	75	mA	V <sub>OLD</sub> = 1.65V Max	
I <sub>OHD</sub>		5.5			-50	-75	mA	V <sub>OHD</sub> = 3.85V Min	
I <sub>CC</sub>	Maximum Quiescent Supply Current	5.5		4.0	80.0	40.0	μA	V <sub>IN</sub> = V <sub>CC</sub> or GND	

\*All outputs loaded; thresholds on input associated with output under test.

†Maximum test duration 2.0 ms, one output loaded at a time.

Note: I<sub>CC</sub> for 54ACT @ 25°C is identical to 74ACT @ 25°C.

**AC Electrical Characteristics:** See Section 2 for waveforms

Symbol	Parameter	V <sub>CC</sub> * (V)	74AC			54AC		74AC		Units	Fig. No.
			T <sub>A</sub> = +25°C C <sub>L</sub> = 50 pF			T <sub>A</sub> = -55°C to +125°C C <sub>L</sub> = 50 pF		T <sub>A</sub> = -40°C to +85°C C <sub>L</sub> = 50 pF			
			Min	Typ	Max	Min	Max	Min	Max		
f <sub>max</sub>	Maximum Clock Frequency	3.3 5.0	90 100	100 125		65 90		70 100	MHz		
t <sub>PLH</sub>	Propagation Delay CP to Q <sub>n</sub>	3.3 5.0	2.0 1.5	9.0 6.0	11.5 8.5	1.0 1.5	14.0 10.5	1.5 1.0	12.5 9.5	ns	2-3,4
t <sub>PHL</sub>	Propagation Delay CP to Q <sub>n</sub>	3.3 5.0	2.0 1.5	8.5 6.0	11.0 8.0	1.0 1.5	13.0 10.0	1.5 1.0	12.0 9.0	ns	2-3,4
t <sub>PHL</sub>	Propagation Delay MR to Q <sub>n</sub>	3.3 5.0	2.5 1.5	9.0 7.0	11.5 9.0	1.0 1.5	13.5 11.0	2.0 1.5	12.5 10.5	ns	2-3,4

\*Voltage Range 3.3 is 3.3V ±0.3V  
Voltage Range 5.0 is 5.0V ±0.5V

**AC Operating Requirements:** See Section 2 for waveforms

Symbol	Parameter	V <sub>CC</sub> * (V)	74AC		54AC		74AC		Units	Fig. No.
			T <sub>A</sub> = +25°C C <sub>L</sub> = 50 pF		T <sub>A</sub> = -55°C to +125°C C <sub>L</sub> = 50 pF		T <sub>A</sub> = -40°C to +85°C C <sub>L</sub> = 50 pF			
			Typ	Guaranteed Minimum						
t <sub>s</sub>	Setup Time, HIGH or LOW D <sub>n</sub> to CP	3.3 5.0	2.5 2.0	6.5 5.0		7.5 5.5		7.0 5.5	ns	2-7
t <sub>h</sub>	Hold Time, HIGH or LOW D <sub>n</sub> to CP	3.3 5.0	1.0 0.5	3.0 3.0		3.0 3.0		3.0 3.0	ns	2-7
t <sub>w</sub>	MR Pulse Width, LOW	3.3 5.0	1.0 1.0	5.5 5.0		7.0 5.0		7.0 5.0	ns	2-4
t <sub>w</sub>	CP Pulse Width	3.3 5.0	1.0 1.0	5.5 5.0		7.0 5.0		7.0 5.0	ns	2-4
t <sub>rec</sub>	Recovery Time MR to CP	3.3 5.0	0 0	2.5 2.0		3.0 2.0		2.5 2.0	ns	2-4,7

\*Voltage Range 3.3 is 3.3V ±0.3V  
Voltage Range 5.0 is 5.0V ±0.5V

**AC Electrical Characteristics:** See Section 2 for waveforms

Symbol	Parameter	V <sub>CC</sub> * (V)	74ACT			54ACT		74ACT		Units	Fig. No.
			T <sub>A</sub> = +25°C C <sub>L</sub> = 50 pF			T <sub>A</sub> = -55°C to +125°C C <sub>L</sub> = 50 pF		T <sub>A</sub> = -40°C to +85°C C <sub>L</sub> = 50 pF			
			Min	Typ	Max	Min	Max	Min	Max		
f <sub>max</sub>	Maximum Clock Frequency	5.0	165	200		95		140	MHz		
t <sub>PLH</sub>	Propagation Delay CP to Q <sub>n</sub>	5.0	1.5	7.0	10.5	1.5	12.5	1.5	11.5	ns	2-3,4
t <sub>PHL</sub>	Propagation Delay CP to Q <sub>n</sub>	5.0	1.5	7.0	10.5	1.5	13.0	1.5	11.5	ns	2-3,4
t <sub>PHL</sub>	Propagation Delay MR to Q <sub>n</sub>	5.0	1.5	6.5	9.5	1.5	12.0	1.5	11.0	ns	2-3,4

\*Voltage Range 5.0 is 5.0V ±0.5V

**AC Operating Requirements:** See Section 2 for waveforms

Symbol	Parameter	V <sub>CC</sub> * (V)	74ACT	54ACT	74ACT	Units	Fig. No.	
			T <sub>A</sub> = +25°C C <sub>L</sub> = 50 pF	T <sub>A</sub> = -55°C to +125°C C <sub>L</sub> = 50 pF	T <sub>A</sub> = -40°C to +85°C C <sub>L</sub> = 50 pF			
			Typ	Guaranteed Minimum				
t <sub>s</sub>	Setup Time, HIGH or LOW D <sub>n</sub> to CP	5.0	0.5	1.5	3.0	1.5	ns	2-7
t <sub>h</sub>	Hold Time, HIGH or LOW D <sub>n</sub> to CP	5.0	1.0	2.0	2.0	2.0	ns	2-7
t <sub>w</sub>	$\overline{MR}$ Pulse Width, LOW	5.0	1.5	3.0	5.0	3.5	ns	2-4
t <sub>w</sub>	CP Pulse Width, HIGH OR LOW	5.0	1.5	3.0	5.0	3.5	ns	2-4
t <sub>rec</sub>	Recovery Time $\overline{MR}$ to CP	5.0	-1.0	0.5	1.0	0.5	ns	2-4,7

\*Voltage Range 5.0 is 5.0V ± 0.5V

**Capacitance**

Symbol	Parameter	Typ	Units	Conditions
C <sub>IN</sub>	Input Capacitance	4.5	pF	V <sub>CC</sub> = OPEN
C <sub>PD</sub>	Power Dissipation Capacitance	85.0	pF	V <sub>CC</sub> = 5.0V