

**MAXIM****350MHz, Ultra-Low-Noise Op Amps****General Description**

The MAX4106/MAX4107 op amps combine high-speed performance with ultra-low-noise performance. The MAX4106 is compensated for closed-loop gains of  $5V/V$ , while the MAX4107 is stable in closed-loop gains of  $10V/V$  or greater.

The MAX4106/MAX4107 require only 15mA of supply current while delivering a 350MHz or a 300MHz bandwidth, respectively. Voltage noise is an ultra-low  $0.75nV/\sqrt{Hz}$ , while a low-distortion architecture provides a spurious-free dynamic range (SFDR) of 63dB at 5MHz.

These high-speed op amps have a wide output voltage swing of  $\pm 3.2V$  and a high current-drive capability of 80mA.

**Applications**

Ultra-Low-Noise ADC Preamp  
 Ultrasound  
 Low-Noise Preamplifier  
 High-Performance Receivers  
 Active Filters  
 Pulse/RF Amplifier

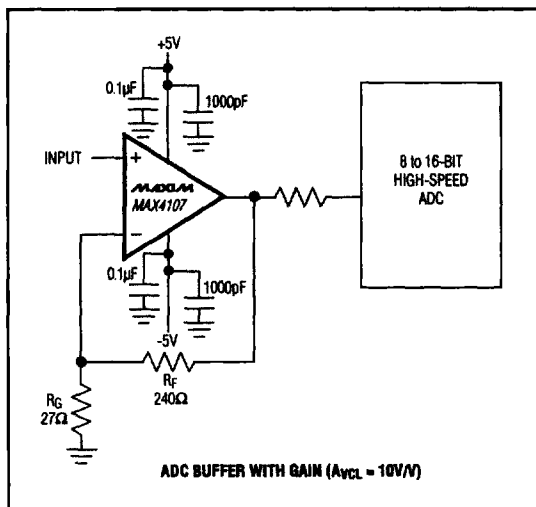
**Typical Application Circuit****Features**

- ◆ 350MHz -3dB Bandwidth (MAX4106)
- ◆ 275V/ $\mu$ s Slew Rate (MAX4106)  
500V/ $\mu$ s Slew Rate (MAX4107)
- ◆ 18ns Settling Time to 0.01%
- ◆  $0.75nV/\sqrt{Hz}$  Voltage Noise
- ◆ High Output Drive: 80mA

**Ordering Information**

PART	TEMP. RANGE	PIN-PACKAGE
MAX4106ESA	-40°C to +85°C	8 SO
MAX4107ESA	-40°C to +85°C	8 SO

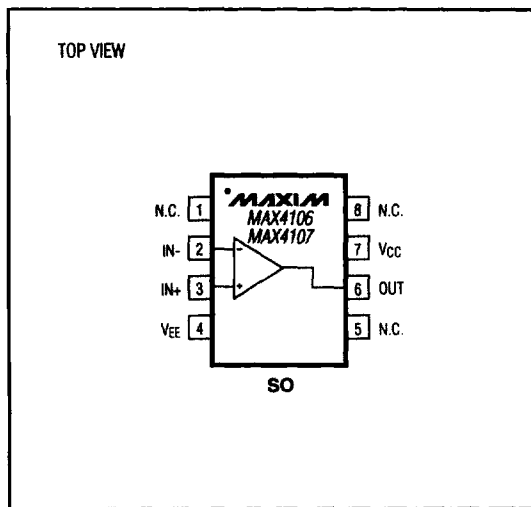
**Pin Configuration****MAX4106/MAX4107****8****MAXIM**

Maxim Integrated Products 8-73

For free samples & the latest literature: <http://www.maxim-ic.com>, or phone 1-800-998-8800

# 350MHz, Ultra-Low-Noise Op Amps

## ABSOLUTE MAXIMUM RATINGS

Power-Supply Voltage (VCC to VEE).....	12V	Operating Temperature Range	
Voltage on Any Pin to Ground or Any Other Pin.....	VCC to VEE	MAX4106ESA/MAX4107ESA.....	-40°C to +85°C
Short-Circuit Duration (VOUT to GND).....	Continuous	Storage Temperature Range.....	-65°C to +160°C
Continuous Power Dissipation (TA = +70°C)		Junction Temperature.....	+150°C
SO (derate 5.88mW/°C above +70°C).....	471mW	Lead Temperature (soldering, 10sec).....	+300°C

Stresses beyond those listed under "Absolute Maximum Ratings" may cause permanent damage to the device. These are stress ratings only, and functional operation of the device at these or any other conditions beyond those indicated in the operational sections of the specifications is not implied. Exposure to absolute maximum rating conditions for extended periods may affect device reliability.

## ELECTRICAL CHARACTERISTICS

(VCC = 5V, VEE = -5V, TA = TMIN to TMAX, typical values are at TA = +25°C, unless otherwise noted.)

PARAMETER	SYMBOL	CONDITIONS	MIN	TYP	MAX	UNITS
<b>DC SPECIFICATIONS</b>						
Input Offset Voltage	VOS	VOUT = 0V		0.250	3	mV
Input Offset Voltage Drift	TCVOS	VOUT = 0V		1.0		μV/°C
Input Bias Current	IB	VOUT = 0V, VIN = -VOS		18	26	μA
Input Offset Current	IOS	VOUT = 0V, VIN = -VOS		0.05	2	μA
Common-Mode Input Resistance	RINCM	Either input		1		MΩ
Common-Mode Input Capacitance	CINCM	Either input		1		pF
Input Voltage Noise	en	f = 10kHz		0.75		nV/√Hz
Integrated Voltage Noise	EnRMS	f = 1MHz to 100MHz		9.5		μVRMS
Input Current Noise	in	f = 10kHz		2.5		pA/√Hz
Integrated Current Noise	InRMS	f = 1MHz to 100MHz		31		nARMS
Common-Mode Input Voltage	VCM		-2.5		2.5	V
Common-Mode Rejection	CMR	VCM = ±2.5V	70	100		dB
Power-Supply Rejection	PSR	VS = ±4.5V to ±5.5V	75	100		dB
Open-Loop Voltage Gain	AVOL	VOUT = ±2.0V, VCM = 0V	RL = ∞	80	100	dB
			RL = 100Ω	80	100	
Supply Current	IS	VIN = 0V		15	19	mA
Output Voltage Swing	VOUT	RL = ∞	±3.2	±3.8		V
		RL = 100Ω	±3.0	±3.5		
Output Current Drive	IOUT	RL = 30Ω, TA = 0°C to +85°C	65	80		mA
Short-Circuit Output Current	Isc	Short to ground		90		mA

# 350MHz, Ultra-Low-Noise Op Amps

**MAX4106/MAX4107**

## ELECTRICAL CHARACTERISTICS (continued)

(VCC = 5V, VEE = -5V, TA = TMIN to TMAX, typical values are at TA = +25°C, unless otherwise noted.)

PARAMETER	SYMBOL	CONDITIONS		MIN	TYP	MAX	UNITS
<b>AC SPECIFICATIONS</b>							
-3dB Bandwidth	BW-3dB	VOUT ≤ 0.1VRMS	MAX4106		350		MHz
			MAX4107		300		
0.1dB Bandwidth	BW0.1dB	MAX4106, AvCL = +5			75		MHz
		MAX4107, AvCL = +10			45		
Slew Rate	SR	-2V ≤ VOUT ≤ 2V	MAX4106		275		V/μs
			MAX4107		500		
Settling Time	ts	-1V ≤ VOUT ≤ 1V, RL = 100Ω, to 0.1%	MAX4106		13		ns
			MAX4107		13		
		-1V ≤ VOUT ≤ 1V, RL = 100Ω, to 0.01%	MAX4106		18		
			MAX4107		18		
Rise/Fall Times	tr, tf	10% to 90%, -2V ≤ VOUT ≤ 2V, RL = 100Ω	MAX4106		13		ns
			MAX4107		6		
		10% to 90%, -50mV ≤ VOUT ≤ 50mV, RL = 100Ω	MAX4106		1		
			MAX4107		1		
Differential Gain	DG	f = 3.58MHz	MAX4106, AvCL = +5		0.04		%
			MAX4107, AvCL = +10		0.03		
Differential Phase	DP	f = 3.58MHz	MAX4106, AvCL = +5		0.02		degrees
			MAX4107, AvCL = +10		0.03		
Input Capacitance	CIN				2		pF
Output Impedance	ZOUT	f = 10MHz			0.7		Ω
Spurious-Free Dynamic Range	SFDR	fc = 5MHz, VOUT = 2Vp-p	MAX4106, AvCL = +5		63		dBc
			MAX4107, AvCL = +10		60		
Two-Tone Third-Order Intercept	IP3	fc = 10MHz			24		dBm

# 350MHz, Ultra-Low-Noise Op Amps

## Typical Operating Characteristics

( $V_{CC} = +5V$ ,  $V_{EE} = -5V$ ,  $R_L = 100\Omega$ ,  $T_A = +25^\circ C$ , unless otherwise noted.)

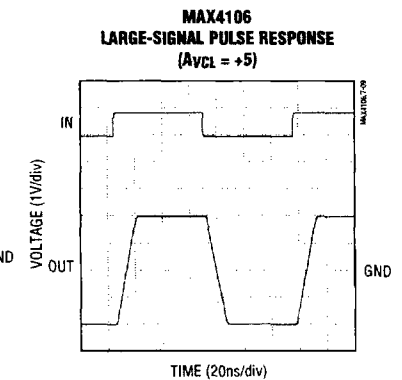
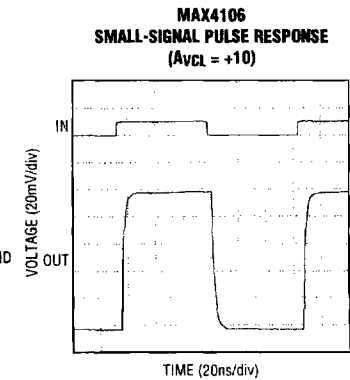
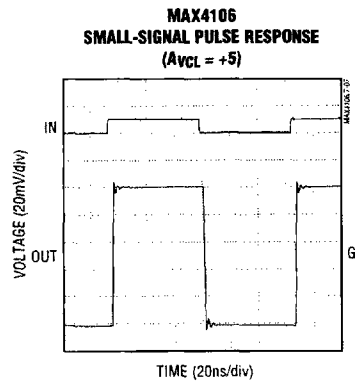
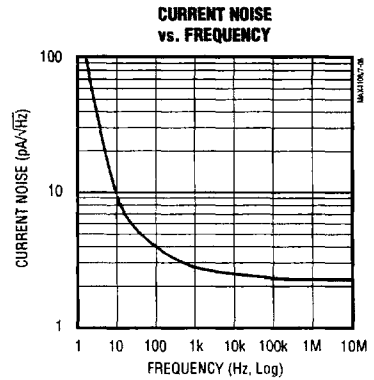
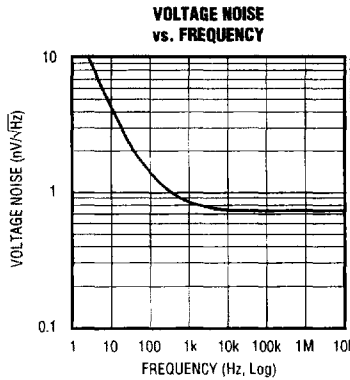
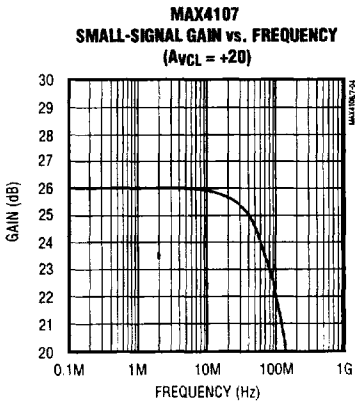
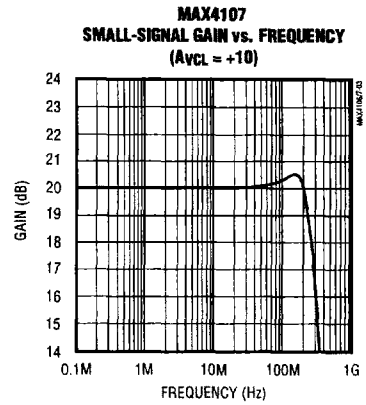
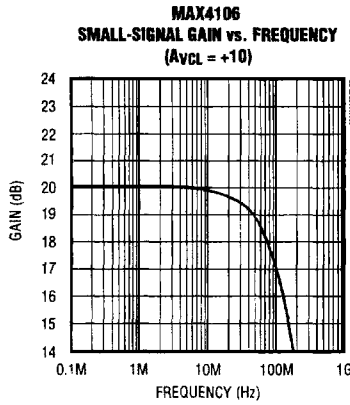
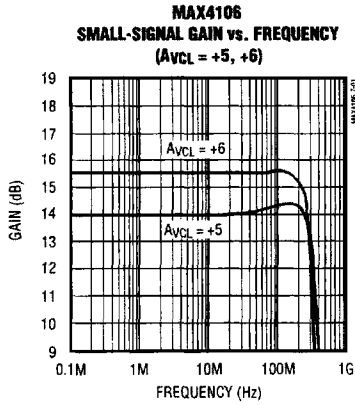

# 350MHz, Ultra-Low-Noise Op Amps

## Typical Operating Characteristics (continued)

(VCC = +5V, VEE = -5V, RL = 100Ω, TA = +25°C, unless otherwise noted.)

**MAX4106/MAX4107**

**MAX4106  
LARGE-SIGNAL PULSE RESPONSE  
(AvCL = +10)**

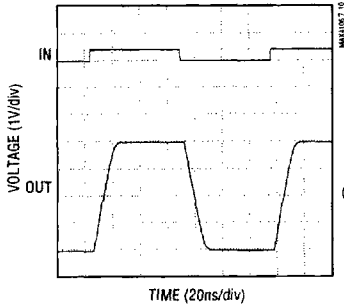

**MAX4107  
SMALL-SIGNAL PULSE RESPONSE  
(AvCL = +10)**

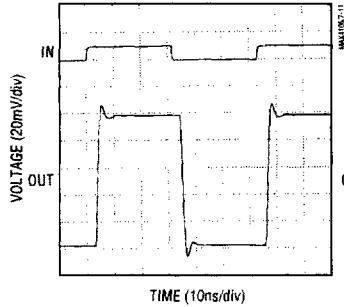

**MAX4107  
SMALL-SIGNAL PULSE RESPONSE  
(AvCL = +20)**

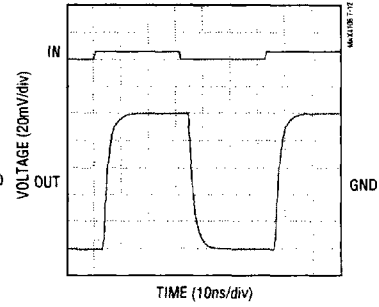

**MAX4107  
LARGE-SIGNAL PULSE RESPONSE  
(AvCL = +10)**

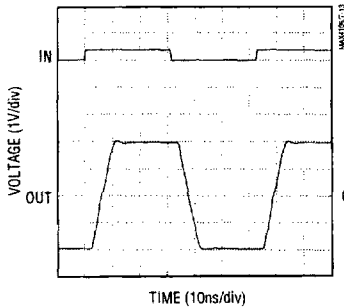

**MAX4107  
LARGE-SIGNAL PULSE RESPONSE  
(AvCL = +20)**

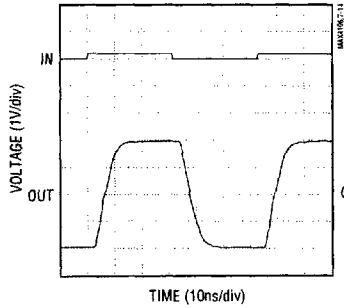

**CLOSED-LOOP OUTPUT IMPEDANCE  
vs. FREQUENCY**

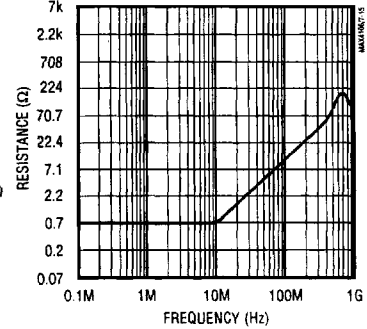

**POWER-SUPPLY REJECTION  
vs. FREQUENCY**

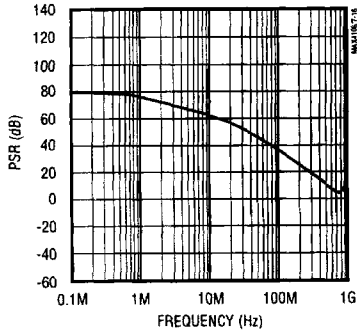

**MAX4106  
COMMON-MODE REJECTION  
vs. FREQUENCY**

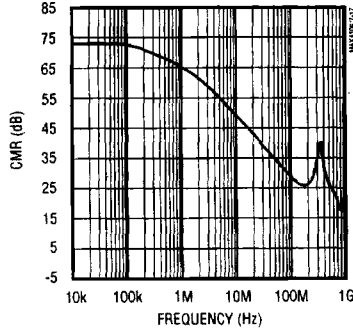

**MAX4107  
COMMON-MODE REJECTION  
vs. FREQUENCY**

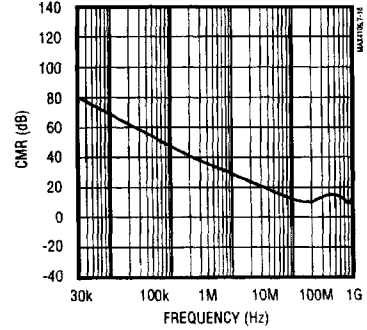

**8**

# 350MHz, Ultra-Low-Noise Op Amps

**MAX4106/MAX4107**

## Typical Operating Characteristics (continued)

( $V_{CC} = +5V$ ,  $V_{EE} = -5V$ ,  $R_L = 100\Omega$ ,  $T_A = +25^\circ C$ , unless otherwise noted.)

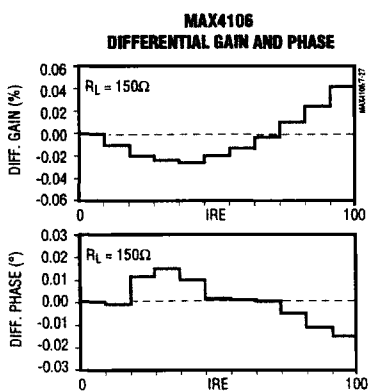
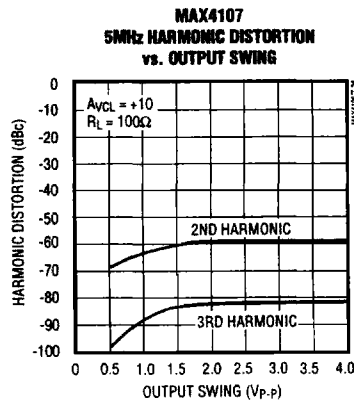
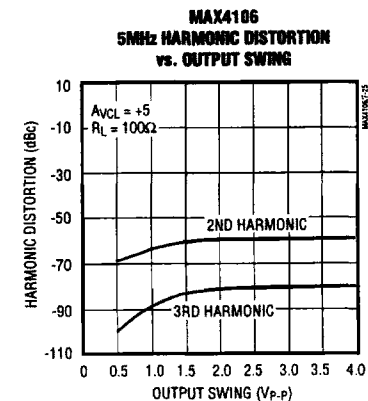
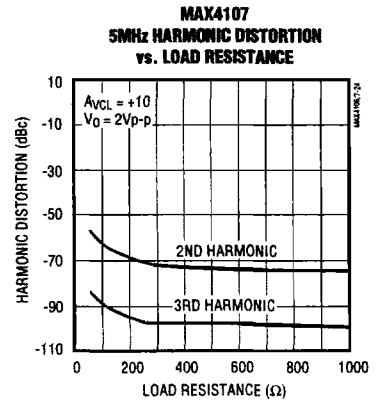
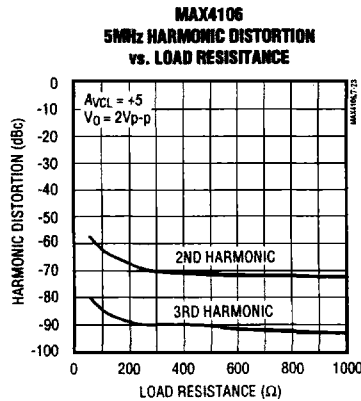
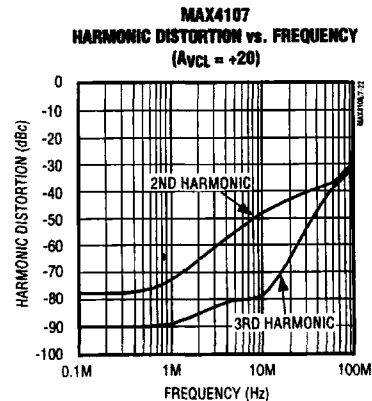
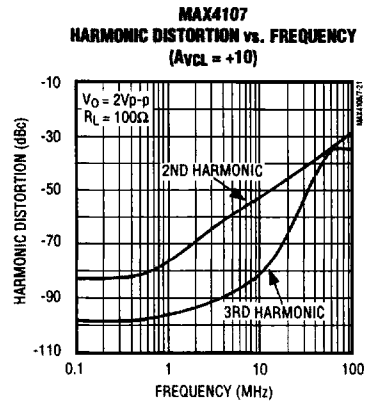
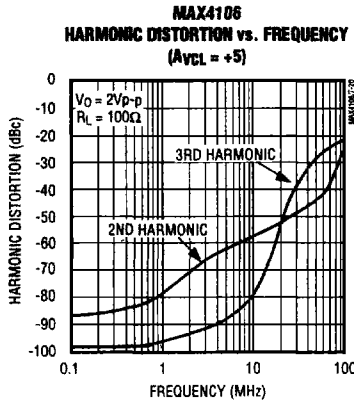
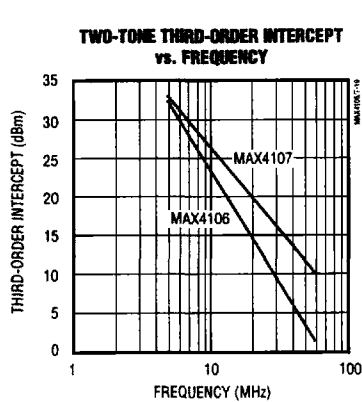

# 350MHz, Ultra-Low-Noise Op Amps

## Typical Operating Characteristics (continued)

( $V_{CC} = +5V$ ,  $V_{EE} = -5V$ ,  $R_L = 100\Omega$ ,  $T_A = +25^\circ C$ , unless otherwise noted.)

MAX4106/MAX4107

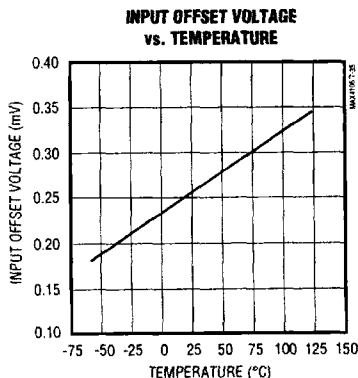
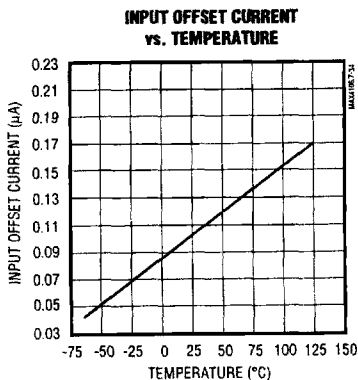
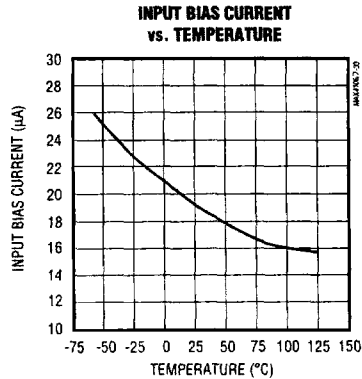
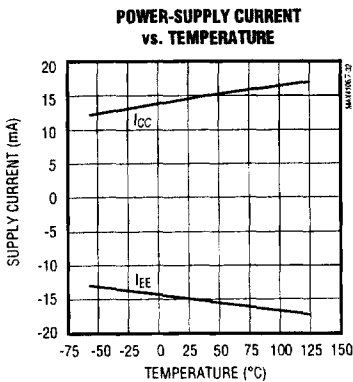
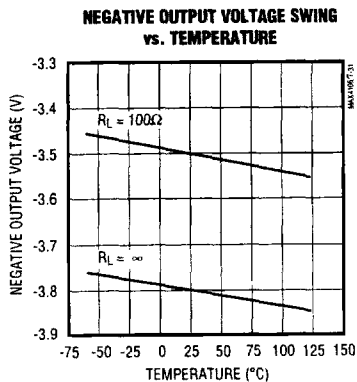
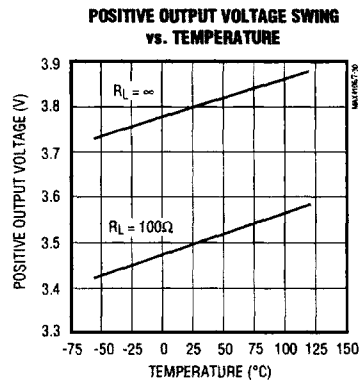
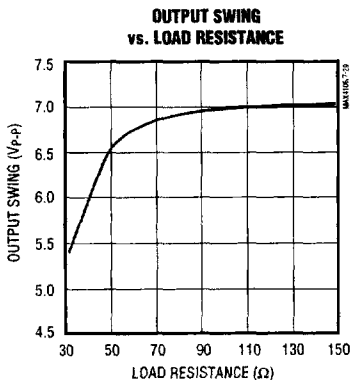
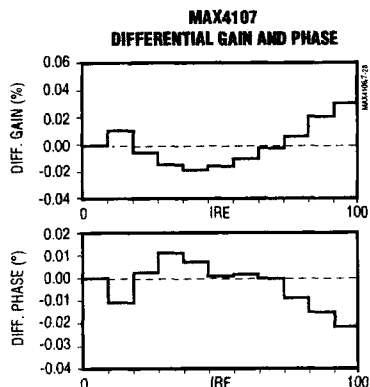

8

## 350MHz, Ultra-Low-Noise Op Amps

### Pin Description

PIN	NAME	FUNCTION
1, 5, 8	N.C.	No Connection, not internally connected
2	IN-	Inverting Input
3	IN+	Noninverting Input
4	VEE	Negative Power Supply, connect to -5V
6	OUT	Amplifier Output
7	VCC	Positive Power Supply, connect to +5V

### General Description

#### Choosing Resistor Values

The values of the gain-setting feedback and input resistors are important design considerations. Large resistor values will increase voltage noise, and will interact with the amplifier's input and PC board capacitance to generate undesirable poles and zeros, which can decrease bandwidth or cause oscillations. For example, a noninverting gain of +5 (MAX4106), using a 1k $\Omega$  feedback resistor combined with 2pF of input capacitance and 0.5pF of board capacitance, will cause a feedback pole at 318MHz. If this pole is within the anticipated amplifier bandwidth, it will jeopardize stability. Reducing the 1k $\Omega$  feedback resistor to 40 $\Omega$  will extend the pole frequency to 8GHz, but could limit output swing by adding 50 $\Omega$  in parallel with the amplifier's load. Clearly the selection of resistor values must be tailored to the specific application.

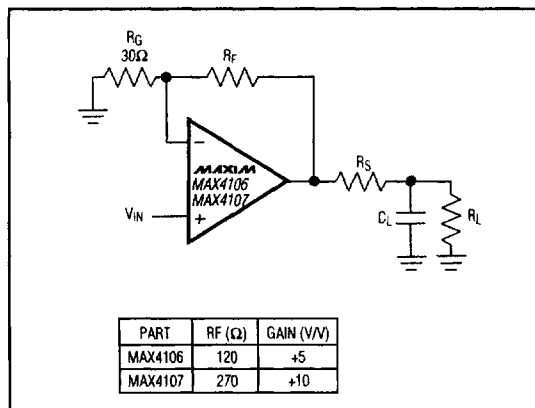

Figure 1a. Using an Isolation Resistor for High Capacitive Loads

The MAX4106/MAX4107 are ultra-low-noise, high-bandwidth op amps. The output noise voltage can be dominated by resistor thermal noise, so keep the feedback and input resistors small. Setting the input resistor to 30 $\Omega$  and choosing the feedback resistor to suit the gain will provide excellent AC performance without significantly degrading noise performance.

#### Driving Capacitive Loads

The MAX4106/MAX4107 are optimized for AC performance. They are not designed to drive highly reactive loads. Reactive loads will decrease phase margin and may produce excessive ringing and oscillation. Figure 1a shows a circuit that eliminates this problem, and Figure 1b is a graph of the optimal isolation resistor ( $R_S$ ) vs. capacitive load. Figures 2a and 2b show how a capacitive load causes excessive peaking of the amplifier's bandwidth if the capacitive load is not isolated ( $R_S$ ) from the amplifier. A small isolation resistor (usually 10 $\Omega$  to 20 $\Omega$ ) placed before the reactive load prevents ringing and oscillation. At higher capacitive loads, AC performance will be controlled by the interaction of the load capacitance and isolation resistor. Figures 3a and 3b show the effect of an isolation resistor on the MAX4106/MAX4107 closed-loop response.

Coaxial cable and other transmission lines are easily driven when terminated at both ends with their characteristic impedance. When driving back-terminated transmission lines, the capacitance of the transmission line is essentially eliminated.

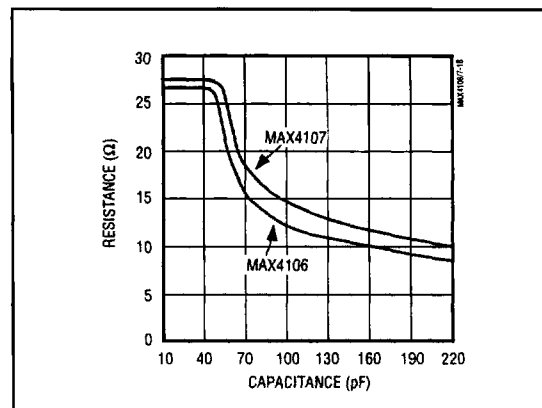

Figure 1b. Optimal Isolation Resistor ( $R_S$ ) vs. Capacitive Load



# 350MHz, Ultra-Low-Noise Op Amps

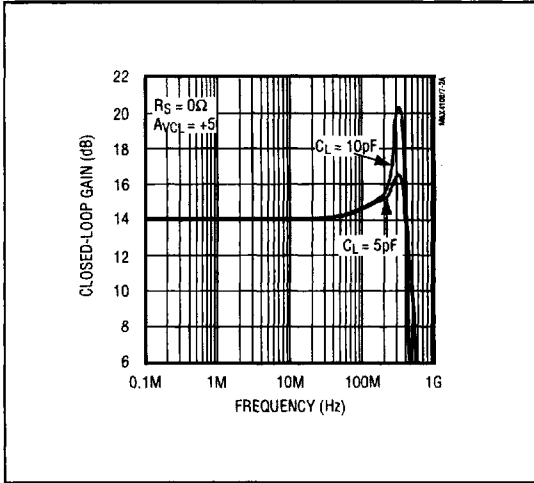

Figure 2a. MAX4106 Response vs. Capacitive Load—No Resistive ( $R_S$ ) Isolation (circuit shown in Figure 1)

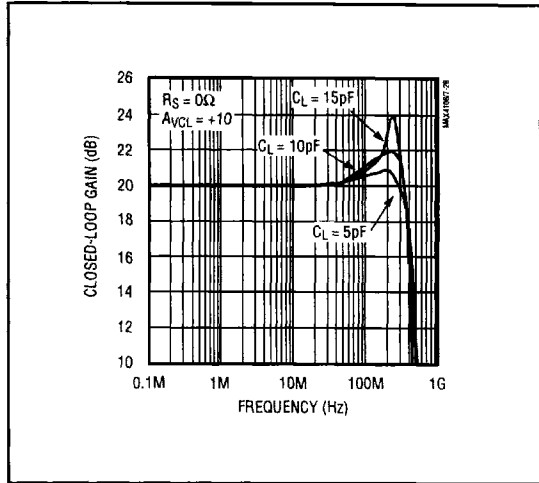

Figure 2b. MAX4107 Response vs. Capacitive Load—No Isolation ( $R_S$ ) Resistor (circuit shown in Figure 1)

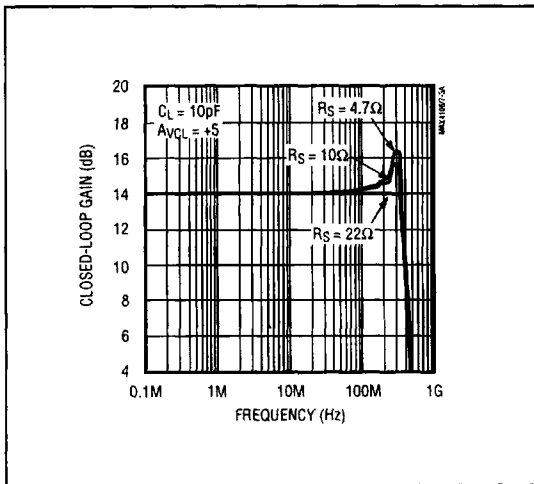

Figure 3a. MAX4106 Response vs. Capacitive Load with Resistive ( $R_S$ ) Isolation (circuit shown in Figure 1)

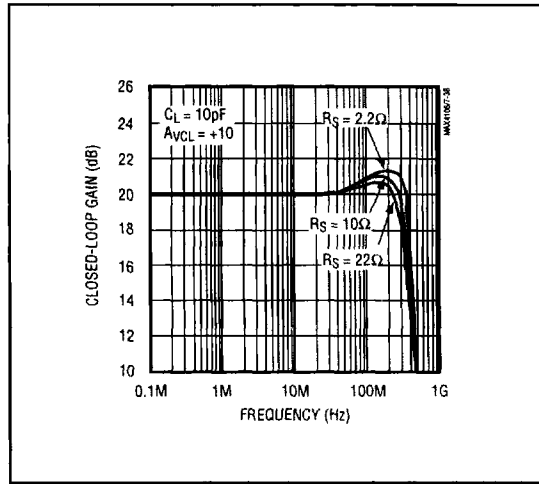

Figure 3b. MAX4107 Response vs. Capacitive Load with Resistive ( $R_S$ ) Isolation (circuit shown in Figure 1)

**MAX4106/MAX4107**

# **350MHz, Ultra-Low-Noise Op Amps**

\_\_\_\_\_ **Chip Information**

TRANSISTOR COUNT: 55