

# 8188

## LOW-DROPOUT REGULATORS — HIGH EFFICIENCY

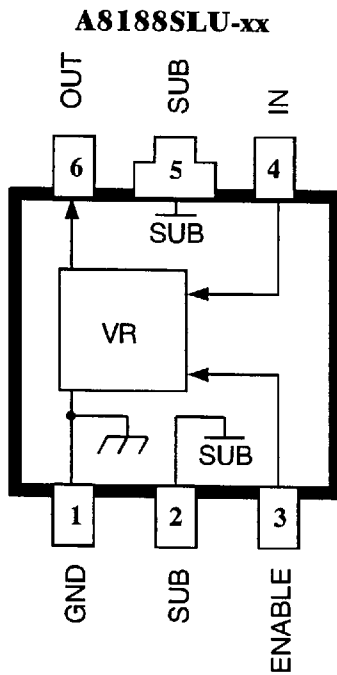

Dwg. PS-021-2

where "-xx" is the required output voltage in tenths.

### ABSOLUTE MAXIMUM RATINGS

Input Voltage, $V_I$ .....	10 V
Peak Output Current, $I_{O(peak)}$ .....	250 mA*
Enable Input Voltage, $V_E$ .....	$V_I$
Operating Temperature Range, $T_A$ .....	-20°C to +85°C
Junction Temperature, $T_J$ .....	+150°C†
Storage Temperature Range, $T_S$ .....	-40°C to +150°C

\* Output current rating is limited by input voltage, duty cycle, and ambient temperature. Under any set of conditions, do not exceed a junction temperature of +150°C. See following pages.

† Fault conditions that produce excessive junction temperature will activate device thermal shutdown circuitry. These conditions can be tolerated but should be avoided.

Designed specifically to meet the requirement for extended operation of battery-powered equipment such as cordless and cellular telephones, the A8188S— voltage regulators offer the reduced dropout voltage and quiescent current essential for maximum battery life. Applicable also to palmtop computers and personal data assistants, these devices deliver a regulated output at up to 250 mA (transient), which is limited only by package power dissipation. Regulated output voltages between 2.5 V and 3.3 V are trimmed at wafer probe.

A PMOS pass element provides a typical dropout voltage of only 90 mV at 60 mA of load current. The low dropout voltage permits deeper battery discharge before output regulation is lost. Quiescent current does not increase significantly as the dropout voltage is approached, an ideal feature in standby/resume power systems where data integrity is crucial. Regulator accuracy and excellent temperature characteristics are provided by a bandgap reference. The A8188SL-xx and A8188SLU-xx include ENABLE inputs to give the designer complete control over power up, standby, or power down.

These devices are supplied in a 6-lead small-outline plastic package similar to the SOT-89/TO-243AA (suffix 'LU') or, without the ENABLE function, in a standard 3-lead SOT-89/TO-243AA small-outline plastic transistor package (suffix 'LT'). Dual regulators (A8188SL-xx) are provided in an 8-lead SOIC package. All devices are rated for operation over a temperature range of -20°C to +85°C.

### FEATURES AND BENEFITS

- High Efficiency Provides Extended Battery Life
- 90 mV Typical Dropout Voltage at  $I_O = 60$  mA
- 55  $\mu$ A Typical Quiescent Current  
Less Than 1  $\mu$ A "Sleep" Current
- 250 mA Peak Output Current
- Improved PSRR and Transient Performance
- Internal Thermal Protection

### APPLICATIONS

- Cordless and Cellular Telephones
- Personal Data Assistants
- Personal Communicators
- Palmtop Computers

Always order by complete part number, e.g., **A8188SLU-30**.



# 8188 LOW-DROPOUT REGULATORS

## FUNCTIONAL BLOCK DIAGRAM (A8188SLU-xx shown)

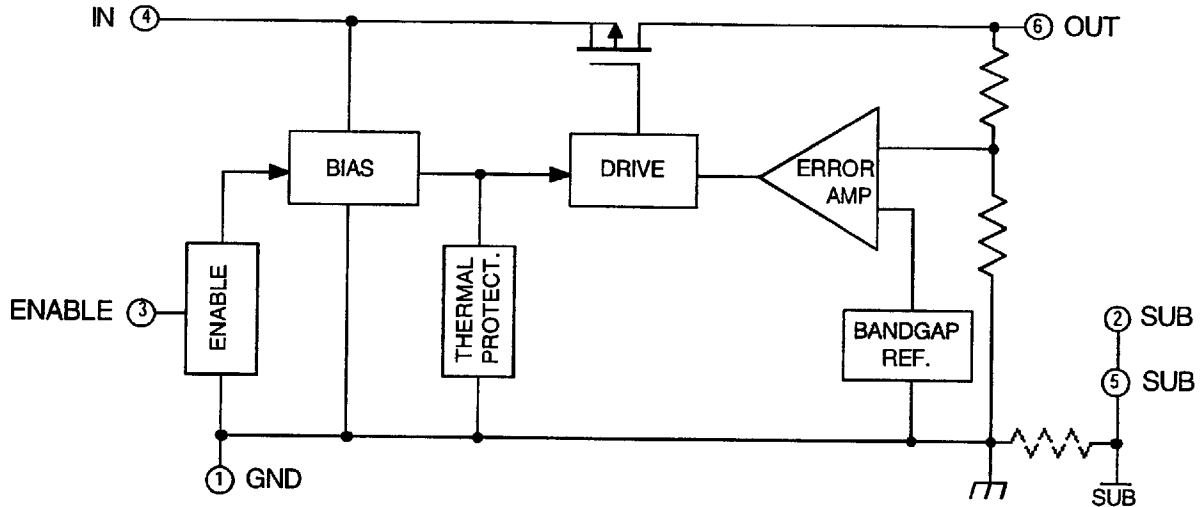

Dwg. FS-012-3

Terminal numbering is in accordance with EIA/JEDEC convention. Where EIAJ conventions apply, the tab is not numbered, resulting in terminal 6 being designated terminal 5.

For proper operation, terminals 1 and 2 must be externally connected together.

### A8188SLT-xx

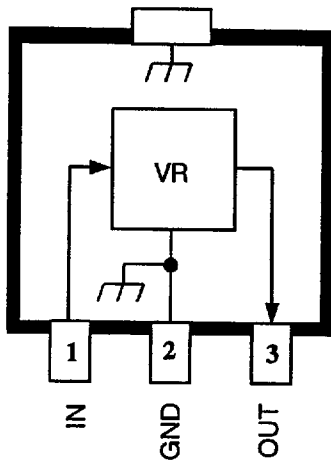

Dwg. PS-022-2

### A8188SL-xx

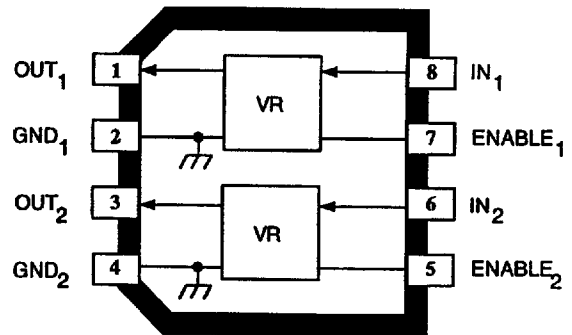

Dwg. PS-023

NOTE — There is an indeterminate resistance between terminals 2 and 4. For proper operation, terminals 2 and 4 must be externally connected together.



115 Northeast Cutoff, Box 15036  
Worcester, Massachusetts 01615-0036 (508) 853-5000  
Copyright © 1997, Allegro MicroSystems, Inc.

0504338 0009071 451

# 8188 LOW-DROPOUT REGULATORS

**A8188SL-xx Maximum Allowable Total Average Output Current\*** with device mounted on 2.24" x 2.24" (56.9 mm x 56.9 mm) solder-coated copper-clad board in still air.

T <sub>A</sub>	Allowable Total Average (10 ms) Output Current in Milliamperes with T <sub>J</sub> = 150°C, Duty Cycle = 100%†								
	V <sub>I</sub> - V <sub>O</sub>								
	1.0	1.5	2.0	2.5	3.0	4.0	5.0	6.0	7.0*
25°C	500	500	500	460	385	285	230	190	165
50°C	500	500	460	370	305	230	185	150	130
70°C	500	490	370	295	245	185	145	120	105
85°C	500	400	300	240	200	150	120	100	85

\* Absolute maximum peak output current rating for either output is 250 mA; absolute maximum input voltage is 10 V.

$$\dagger I_O = (T_J - T_A) / ([V_I - V_O] R_{\theta JA} \times dc) = (150 - T_A) / ([V_I - V_O] \times 108 \times 1.00)$$

Output current rating can be increased (to 250 mA maximum per output) by additional heat sinking or reducing the duty cycle. Conditions that produce excessive junction temperature will activate device thermal shutdown circuitry. These conditions can be tolerated but should be avoided.

**A8188SLT-xx and A8188SLU-xx Maximum Allowable Output Current** with device mounted on 2.24" x 2.24" (56.9 mm x 56.9 mm) solder-coated copper-clad board in still air.

T <sub>A</sub>	Allowable Average (10 ms) Output Current in Milliamperes with T <sub>J</sub> = 150°C, Duty Cycle = 100%†								
	V <sub>I</sub> - V <sub>O</sub>								
	1.0	1.5	2.0	2.5	3.0	4.0	5.0	6.0	7.0*
25°C	250	250	240	190	160	120	95	80	65
50°C	250	250	190	155	125	95	75	65	55
70°C	250	205	155	120	100	75	60	50	40
85°C	250	165	125	100	80	60	50	40	35

\* Absolute maximum input voltage is 10 V.

$$\dagger I_O = (T_J - T_A) / ([V_I - V_O] R_{\theta JA} \times dc) = (150 - T_A) / ([V_I - V_O] \times 258 \times 1.00)$$

Output current rating can be increased (to 250 mA maximum) by additional heat sinking or reducing the duty cycle. Conditions that produce excessive junction temperature will activate device thermal shutdown circuitry. These conditions can be tolerated but should be avoided.

Always order by complete part number:

Part Number	Package	R <sub>θJA</sub>
A8188SL-xx	8-Lead SOIC	108°C/W
A8188SLT-xx	3-Lead SOT-89/TO-243AA	258°C/W
A8188SLU-xx	6-Lead SOT-89/TO-243AA	258°C/W

where "-xx" is the required output voltage (V<sub>O(nom)</sub>) in tenths (25 through 33), e.g., -30 = 3.0 volts.

# 8188 LOW-DROPOUT REGULATORS

## ELECTRICAL CHARACTERISTICS at $T_A = +25^\circ\text{C}$ (unless otherwise noted).

Characteristic	Symbol	Test Conditions	Limits			
			Min.	Typ.	Max.	Units
Output Voltage (reference specified $V_{O(nom)}$ )	$V_O$	$4\text{ V} \leq V_I \leq 8\text{ V}$ , $10\ \mu\text{A} \leq I_O \leq 100\text{ mA}^*$	-0.05	0.00	+0.05	V
		$V_I = V_{O(nom)}$ , $I_O = 60\text{ mA}$	-0.30	—	—	V
Output Volt. Temp. Coeff.	$\alpha_{VO}$	$V_I = 6\text{ V}$ , $I_O = 10\text{ mA}$ , $T_J \leq 125^\circ\text{C}$	—	-0.30	—	mV/ $^\circ\text{C}$
Line Regulation	$\Delta V_{O(\Delta V_I)}$	$4\text{ V} \leq V_I \leq 8\text{ V}$ , $I_O = 1\text{ mA}$	—	—	10	mV
Load Regulation	$\Delta V_{O(\Delta I_O)}$	$1\text{ mA} \leq I_O \leq 100\text{ mA}^*$ , $V_I = 8\text{ V}$	—	—	40	mV
		$1\text{ mA} \leq I_O \leq 100\text{ mA}^*$ , $V_I = 6\text{ V}$	—	—	40	mV
		$1\text{ mA} \leq I_O \leq 100\text{ mA}^*$ , $V_I = 4\text{ V}$	—	—	40	mV
Dropout Voltage	$V_{I,min} - V_O$	$I_O = 60\text{ mA}$	—	90	150	mV
		$I_O = 125\text{ mA}^*$	—	190	300	mV
Quiescent Current (GND terminal current)	$I_Q$	$V_I = 8\text{ V}$ , $I_O \leq 1\text{ mA}$ , $V_E \geq 2.0\text{ V}$	—	55	70	$\mu\text{A}$
		$V_I = 8\text{ V}$ , $I_O \leq 100\text{ mA}^*$ , $V_E \geq 2.0\text{ V}$	—	70	85	$\mu\text{A}$
		$V_I = V_{O(nom)}$ , $I_O = 60\text{ mA}$	—	200	—	$\mu\text{A}$
	$I_{Q(off)}$	$4\text{ V} \leq V_I \leq 8\text{ V}$ , $V_E \leq 0.8\text{ V}$	—	—	1.0	$\mu\text{A}$
ENABLE Input Voltage	$V_{EH}$	$4\text{ V} \leq V_I \leq 8\text{ V}$ , Output ON	2.0	—	—	V
	$V_{EL}$	$4\text{ V} \leq V_I \leq 8\text{ V}$ , Output OFF	—	—	0.8	V
ENABLE Input Current	$I_E$	$V_E = V_I = 8\text{ V}$	—	—	$\pm 1.0$	$\mu\text{A}$
Thermal Shutdown Temp.	$T_J$		150	—	—	$^\circ\text{C}$
Rejection Ratio	PSRR	$V_I = V_{O(nom)} + 1.5\text{ V}$ , $V_I = 100\text{ mV}$ , $I_O = 10\text{ mA}$ , $f = 1\text{ kHz}$	—	60	—	dB
		$f = 10\text{ kHz}$	—	50	—	dB
Noise	$e_n$	$10\text{ Hz} \leq f \leq 100\text{ kHz}$ , $I_O = 10\text{ mA}$ , $C_O = 10\ \mu\text{F}$	—	2.0	—	$\mu\text{V}/\sqrt{\text{Hz}}$

Typical values are at  $T_A = +25^\circ\text{C}$  and are given for circuit design information only.

\* Pulse test ( $\leq 20\text{ ms}$ ). See previous page for duty cycle limitations.



115 Northeast Cutoff, Box 15036  
Worcester, Massachusetts 01615-0036 (508) 853-5000

0504338 0009073 224

# 8188 LOW-DROPOUT REGULATORS

## TYPICAL CHARACTERISTICS

### LOAD REGULATION

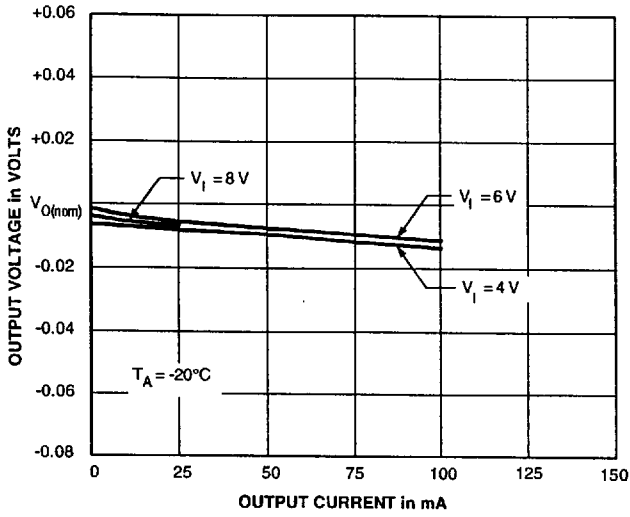

Dwg. GP-052-13

### LINE REGULATION

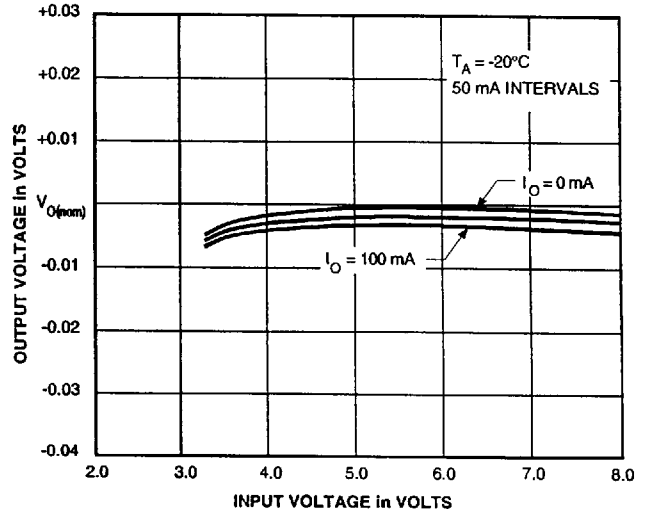

Dwg. GP-053-13

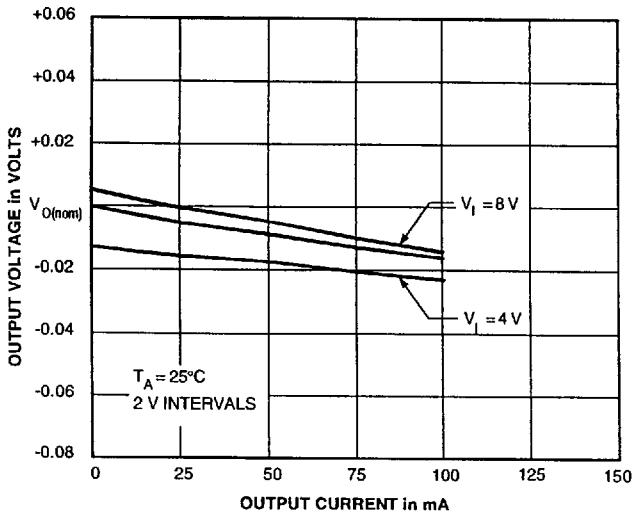

Dwg. GP-052-14

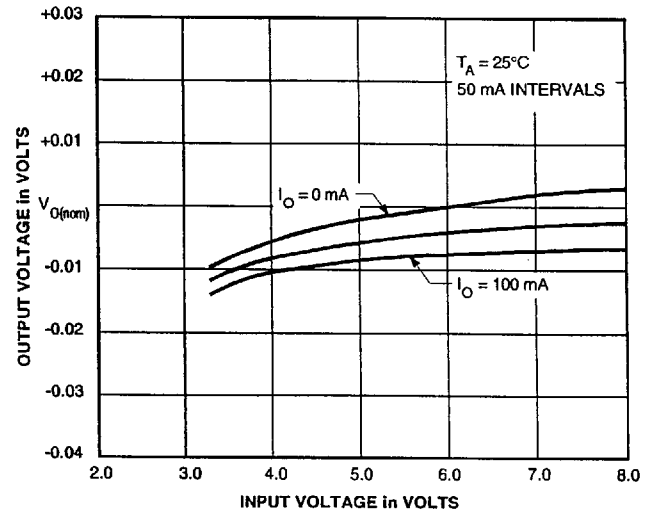

Dwg. GP-053-14

**CAUTION:** Maximum allowable duty cycle will be significantly less than 100% at high temperatures, at high input voltages, or at high output currents. See appropriate Maximum Allowable Output Current table.

# SISS LOW-DROPOUT REGULATORS

## TYPICAL CHARACTERISTICS (cont'd)

### LOAD REGULATION

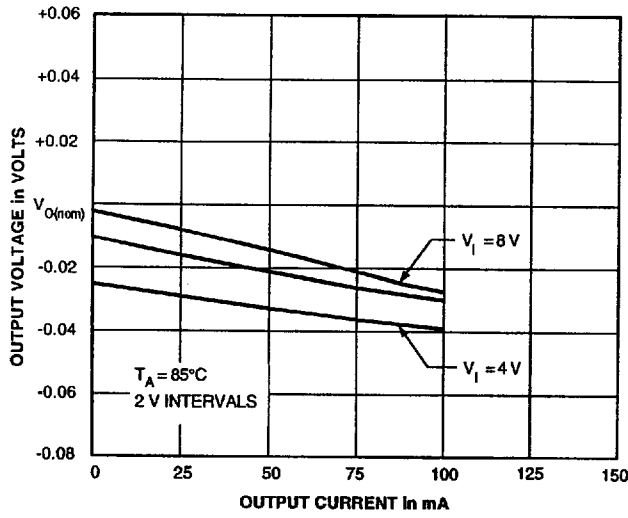

Dwg. GP-052-15

### LINE REGULATION

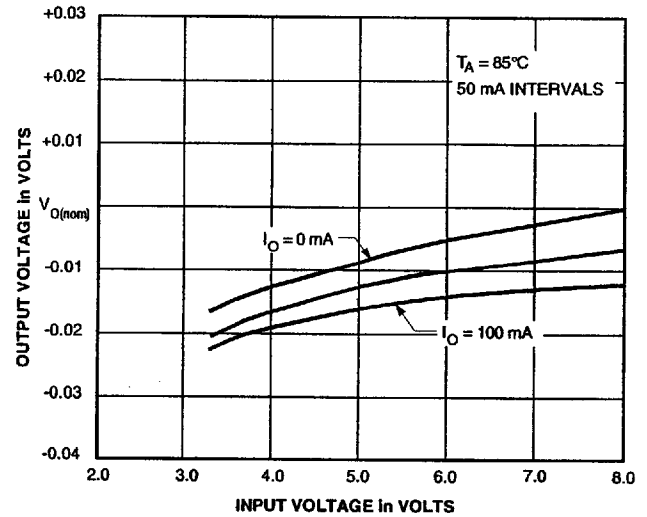

Dwg. GP-053-15

### OUTPUT VOLTAGE

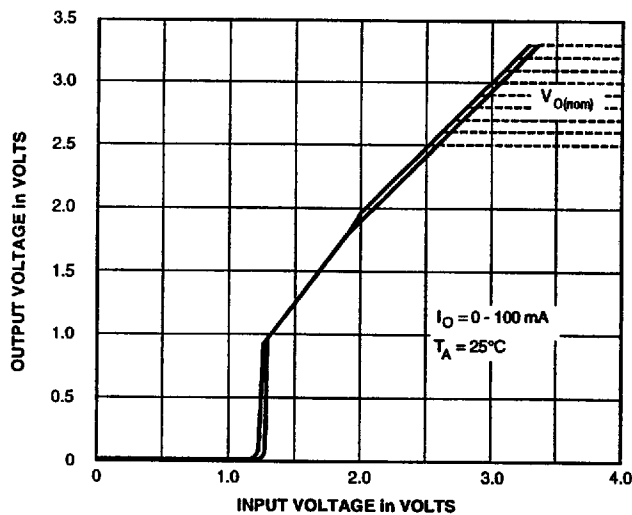

Dwg. GP-058-2

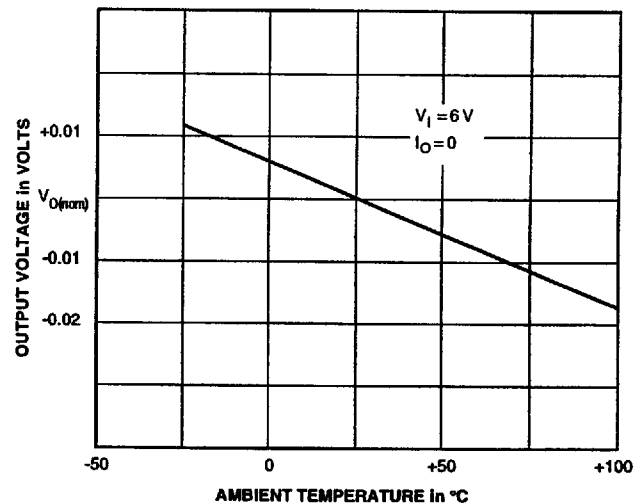

Dwg. GP-050-3

**CAUTION:** Maximum allowable duty cycle will be significantly less than 100% at high temperatures, at high input voltages, or at high output currents. See appropriate Maximum Allowable Output Current table.



115 Northeast Cutoff, Box 15036  
Worcester, Massachusetts 01615-0036 (508) 853-5000

0504338 0009075 0T7

# 8188 LOW-DROPOUT REGULATORS

## TYPICAL CHARACTERISTICS (cont'd)

### QUIESCENT (GROUND TERMINAL) CURRENT

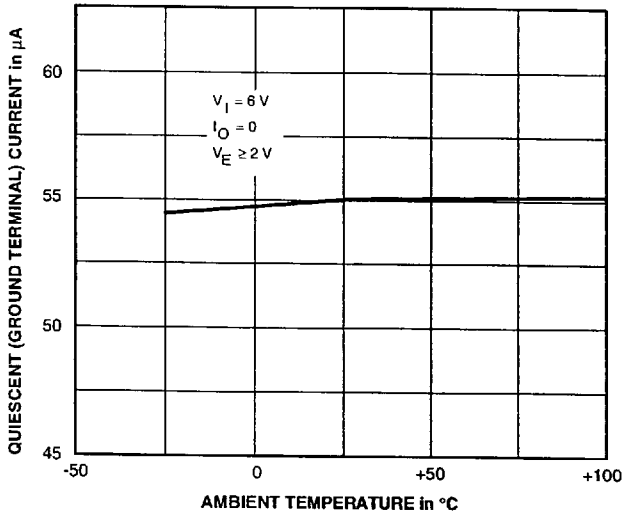

Dwg. GP-051-3

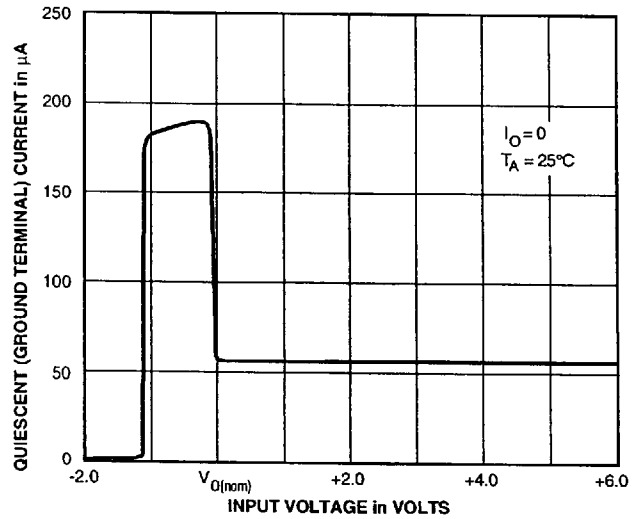

Dwg. GP-058-1

### DROPOUT VOLTAGE

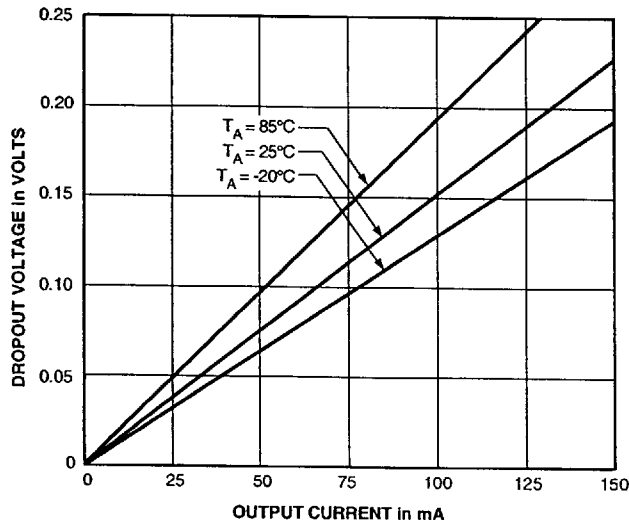

Dwg. GP-054-2

**CAUTION:** Maximum allowable duty cycle will be significantly less than 100% at high temperatures, at high input voltages, or at high output currents. See appropriate Maximum Allowable Output Current table.

# 8188 LOW-DROPOUT REGULATORS

## TYPICAL CHARACTERISTICS (concluded)

### LOAD TRANSIENT PERFORMANCE

$V_I = 3.2 \text{ V to } 6.2 \text{ V}$ ,  $C_O = 4.7 \mu\text{F}$ ,  $T_A = 25^\circ\text{C}$

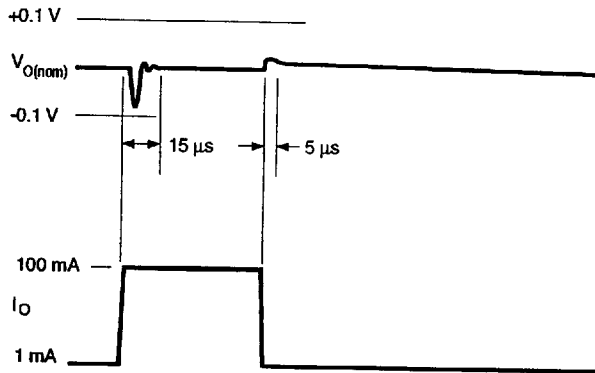

Dwg. WP-028-2

### ENABLE TRANSIENT PERFORMANCE

$V_I = 3.2 \text{ V to } 6.2 \text{ V}$ ,  $C_O = 1 \mu\text{F}$ ,  $T_A = 25^\circ\text{C}$

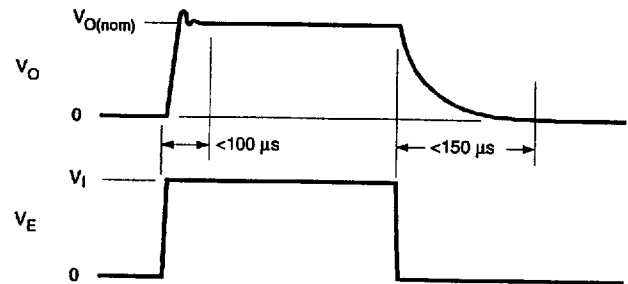

Dwg. WP-027-3



115 Northeast Cutoff, Box 15036  
Worcester, Massachusetts 01615-0036 (508) 853-5000



**S188  
LOW-DROPOUT  
REGULATORS**

**A8188SL-xx**

Dimensions in Inches  
(for reference only)

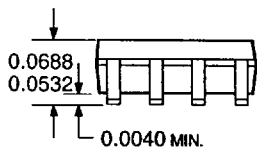
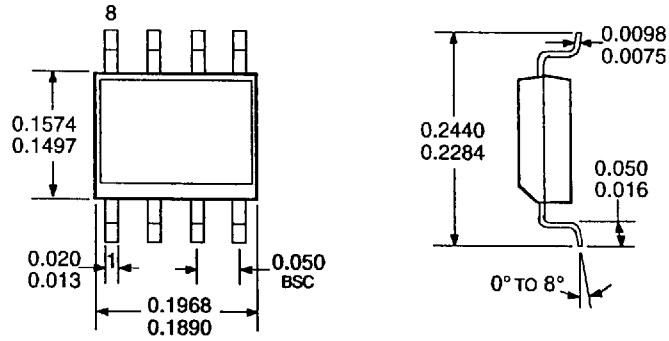

Dwg. MA-007-8 in

Dimensions in Millimeters  
(controlling dimensions)

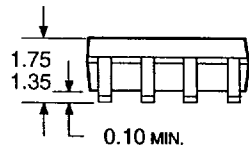
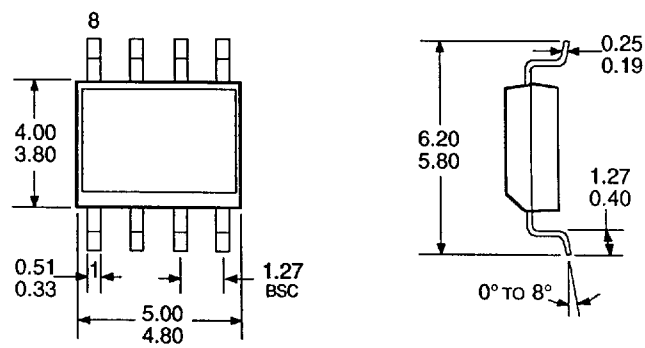

Dwg. MA-007-8 mm

- NOTES: 1. Lead spacing tolerance is non-cumulative.  
2. Exact body and lead configuration at vendor's option within limits shown.

# 8188 LOW-DROPOUT REGULATORS

## A8188SLT-xx

Dimensions in Inches  
(for reference only)

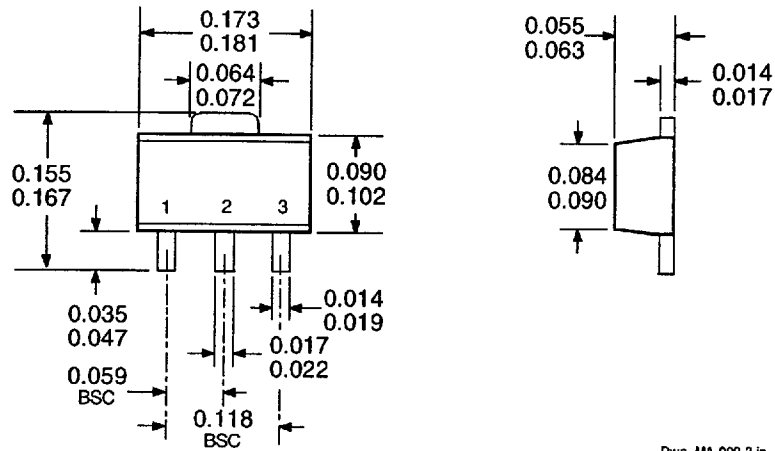

Dwg. MA-008-3 in

Dimensions in Millimeters  
(controlling dimensions)

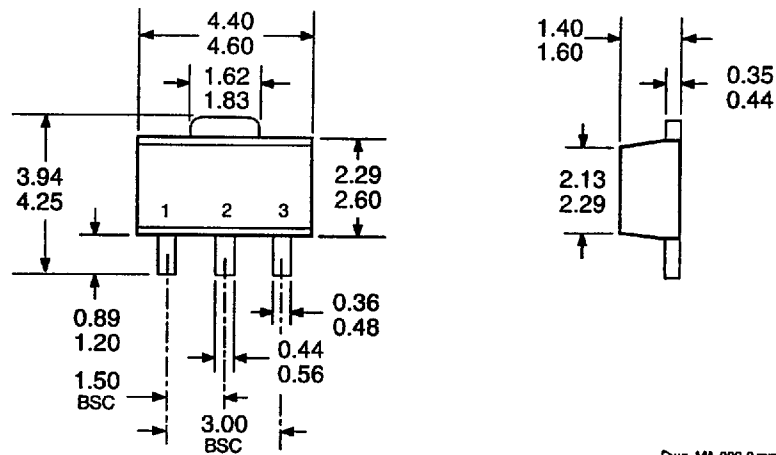

Dwg. MA-008-3 mm

- NOTES: 1. Lead spacing tolerance is non-cumulative.  
2. Exact body and lead configuration at vendor's option within limits shown.



115 Northeast Cutoff, Box 15036  
Worcester, Massachusetts 01615-0036 (508) 853-5000

0504338 0009079 742

**8188**  
**LOW-DROPOUT**  
**REGULATORS**

**A8188SLU-xx**

Dimensions in Inches  
 (for reference only)

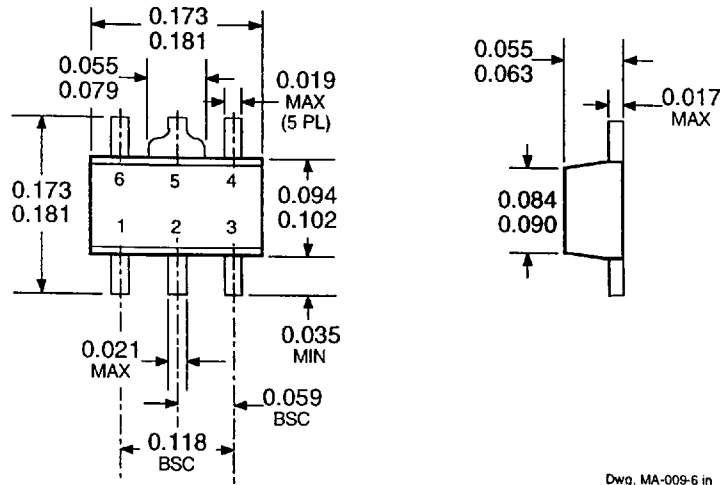

Dimensions in Millimeters  
 (controlling dimensions)

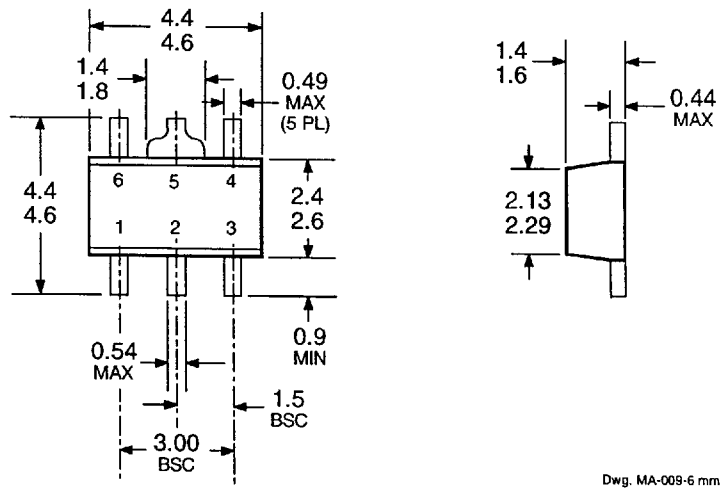

- NOTES: 1. Lead spacing tolerance is non-cumulative.  
 2. Exact body and lead configuration at vendor's option within limits shown.  
 3. Terminal numbering is in accordance with EIA/JEDEC convention.  
 Where EIAJ conventions apply, the tab is not numbered, resulting in terminal 6 being designated terminal 5.