

TYPES SN54196, SN54197, SN54LS196, SN54LS197, SN54S196, SN54S197, SN74196, SN74197, SN74LS196, SN74LS197, SN74S196, SN74S197 50/30/100-MHz PRESETTABLE DECADE OR BINARY COUNTERS/LATCHES

OCTOBER 1976—REVISED APRIL 1985

- Performs BCD, Bi-Quinary, or Binary Counting
- Fully Programmable
- Fully Independent Clear Input
- Input Clamping Diodes Simplify System Design
- Output Q_A Maintains Full Fan-out Capability In Addition to Driving Clock-2 Input

SN54196, SN54LS196, SN54S196,
SN54197, SN54LS197, SN54S197 . . . J OR W PACKAGE
SN74196, SN74197 . . . J OR N PACKAGE
SN74LS196, SN74S196,
SN74LS197, SN74S197 . . . D, J OR N PACKAGE

(TOP VIEW)

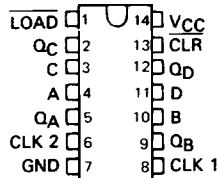

SN54LS196, SN54S196
SN54LS197, SN54S197 . . . FK PACKAGE
SN74LS196, SN74S196
SN74LS197, SN74S197 . . . FN PACKAGE

(TOP VIEW)

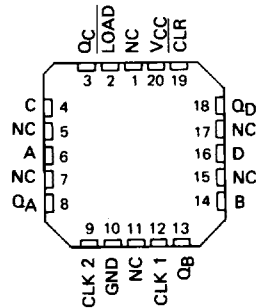

NC - No internal connection

description

These high-speed monolithic counters consist of four d-c coupled, master-slave flip-flops, which are internally interconnected to provide either a divide-by-two and a divide-by-five counter ('196, 'LS196, 'S196) or a divide-by-two and a divide-by-eight counter ('197, 'LS197, 'S197). These four counters are fully programmable; that is, the outputs may be preset to any state by placing a low on the count/load input and entering the desired data at the data inputs. The outputs will change to agree with the data inputs independent of the state of the clocks.

During the count operation, transfer of information to the outputs occurs on the negative-going edge of the clock pulse. These counters feature a direct clear which when taken low sets all outputs low regardless of the states of the clocks.

These counters may also be used as 4-bit latches by using the count/load input as the strobe and entering data at the data inputs. The outputs will directly follow the data inputs when the count/load is low, but will remain unchanged when the count/load is high and the clock inputs are inactive.

All inputs are diode-clamped to minimize transmission-line effects and simplify system design. These circuits are compatible with most TTL logic families. Series 54, 54LS, and 54S circuits are characterized for operation over the full military temperature range of -55°C to 125°C ; Series 74, 74LS, and 74S circuits are characterized for operation from 0°C to 70°C .

logic symbols†

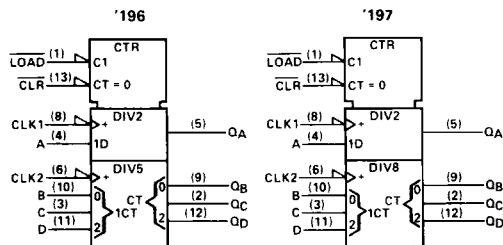

†Pin numbers shown on logic notation are for D, J or N packages.

3

TTL DEVICES

PRODUCTION DATA

This document contains information current as of publication date. Products conform to specifications per the terms of Texas Instruments standard warranty. Production processing does not necessarily include testing of all parameters.

TEXAS
INSTRUMENTS

POST OFFICE BOX 225012 • DALLAS, TEXAS 75265

3-787

**TYPES SN54196, SN54197, SN54LS196, SN54LS197, SN54S196, SN54S197,
SN74196, SN74197, SN74LS196, SN74LS197, SN74S196, SN74S197
50/30/100-MHz PRESETTABLE DECADE OR BINARY COUNTERS/LATCHES**

typical count configurations

'196, 'LS196, and 'S196 typical count configurations and function tables are the same as those for '176.
'197, 'LS197, and 'S197 typical count configurations and function tables are the same as those for '177.

logic diagrams

'196, 'LS196, and 'S196 logic diagrams are the same as those for '176.
'197, 'LS197, and 'S197 logic diagrams are the same as those for '177.

schematics of inputs and outputs

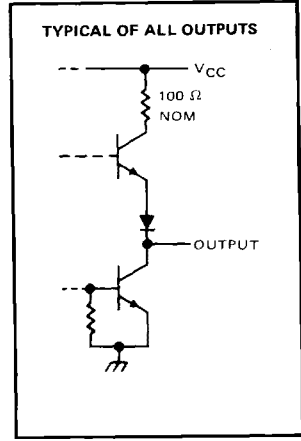
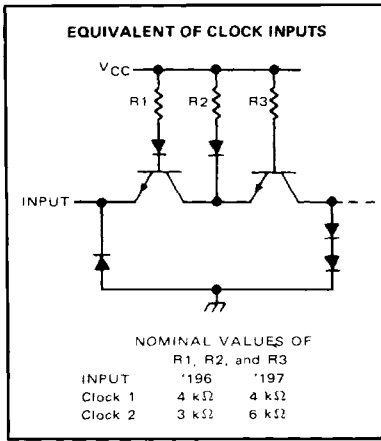
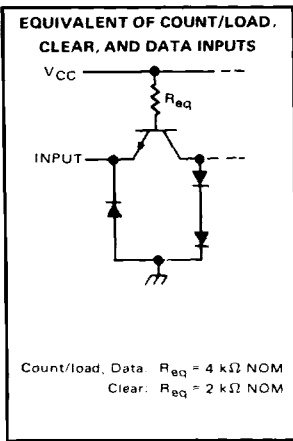

3 TTL DEVICES

TYPES SN54196, SN54197, SN74196, SN74197

50-MHz PRESETTABLE DECADE OR BINARY COUNTERS/LATCHES

absolute maximum ratings over operating free-air temperature range (unless otherwise noted)

Supply voltage, V_{CC} (see Note 1)	7 V
Input voltage	5.5 V
Intermitter voltage (see Note 2)	5.5 V
Operating free-air temperature range: SN54196, SN54197 Circuits	-55°C to 125°C
SN74196, SN74197 Circuits	0°C to 70°C
Storage temperature range	-65°C to 150°C

- NOTES: 1. Voltage values are with respect to network ground terminal.
 2. This is the voltage between two emitters of a multiple-emitter transistor. For this circuit, this rating applies between the clear and count/load inputs.

recommended operating conditions

		SN54196, SN54197			SN74196, SN74197			UNIT		
		MIN	NOM	MAX	MIN	NOM	MAX			
Supply voltage, V_{CC}		4.5	5	5.5	4.75	5	5.25	V		
High-level output current, I_{OH}		-800			-800			μ A		
Low-level output current, I_{OL}		16			16			mA		
Count frequency	Clock 1 input	0		50	0		50	MHz		
	Clock 2 input	0		25	0		25			
Pulse width, t_w	Clock 1 input	10			10			ns		
	Clock 2 input	20			20					
	Clear	15			15					
	Load	20			20					
Input hold time, t_h	High-level data	$t_w(\text{load})$			$t_w(\text{load})$			ns		
	Low-level data	$t_w(\text{load})$			$t_w(\text{load})$					
Input setup time, t_{SU} (see Note 4)	High-level data	10			10			ns		
	Low-level data	15			15					
Count enable time, t_{en} (see Note 3)		20			20			ns		
Operating free-air temperature, T_A		-55			125			0	70	°C

- NOTES: 3. Minimum count enable time is the interval immediately preceding the negative-going edge of the clock pulse during which interval the count/load and clear inputs must both be high to ensure counting.
 4. t_{SU} is measured with respect to load input.

3
TTL DEVICES

TYPES SN54196, SN54197, SN74196, SN74197

50-MHz PRESETTABLE DECADE OR BINARY COUNTERS/LATCHES

electrical characteristics over recommended operating free-air temperature range (unless otherwise noted)

PARAMETER		TEST CONDITIONS†	SN54196, SN74196			SN54197, SN74197			UNIT
			MIN	TYP‡	MAX	MIN	TYP‡	MAX	
V _{IH}	High-level input voltage		2			2			V
V _{IL}	Low-level input voltage		0.8			0.8			V
V _{IK}	Input clamp voltage	V _{CC} = MIN, I _I = -12 mA	-1.5			-1.5			V
V _{OH}	High-level output voltage	V _{CC} = MIN, V _{IH} = 2 V, V _{IL} = 0.8 V, I _{OH} = -800 μA	2.4	3.4		2.4	3.4		V
V _{OL}	Low-level output voltage	V _{CC} = MIN, V _{IH} = 2 V, V _{IL} = 0.8 V, I _{OL} = 16 mA ^f	0.2	0.4		0.2	0.4		V
I _I	Input current at maximum input voltage	V _{CC} = MAX, V _I = 5.5 V	1			1			mA
I _{IH}	High-level input current	Data, count/load	40			40			μA
		Clear, clock 1	80			80			
		Clock 2	120			80			
I _{IL}	Low-level input current	Data, count/load	-1.6			-1.6			mA
		Clear	-3.2			-3.2			
		Clock 1	-4.8			-4.8			
		Clock 2	-6.4			-3.2			
I _{OS}	Short-circuit output current [§]	V _{CC} = MAX	SN54'	-20	-57	-20	-57	mA	
			SN74'	-18	-57	-18	-57		
I _{CC}	Supply current	V _{CC} = MAX. See Note 5	48	59		48	59	mA	

NOTE 5: I_{CC} is measured with all inputs grounded and all outputs open.

† For conditions shown as MIN or MAX, use the appropriate value specified under recommended operating conditions.

‡ All typical values are at V_{CC} = 5 V, T_A = 25° C.

^f Q_A outputs are tested at I_{OL} = 16 mA plus the limit value of I_{IL} for the clock 2 input. This permits driving the clock-2 input while fanning out to 10 Series 54/74 loads.

[§] Not more than one output should be shorted at a time.

3

TTL DEVICES

switching characteristics, V_{CC} = 5 V, T_A = 25° C

PARAMETER	FROM (INPUT)	TO (OUTPUT)	TEST CONDITIONS	SN54196 SN74196			SN54197 SN74197			UNIT
				MIN	TYP	MAX	MIN	TYP	MAX	
f _{max}	Clock 1	Q _A	C _L = 15 pF, R _L = 400 Ω, See Note 6	50	70		50	70		MHz
t _{PLH}	Clock 1	Q _A		7	12		7	12		ns
t _{PHL}				10	15		10	15		
t _{PLH}	Clock 2	Q _B		12	18		12	18		ns
t _{PHL}				14	21		14	21		
t _{PLH}	Clock 2	Q _C		24	36		24	36		ns
t _{PHL}				28	42		28	42		
t _{PLH}	Clock 2	Q _D		14	21		36	54		ns
t _{PHL}				12	18		42	63		
t _{PLH}	A, B, C, D	Q _A , Q _B , Q _C , Q _D		16	24		16	24		ns
t _{PHL}				25	38		25	38		
t _{PLH}	Load	Any		22	33		22	33		ns
t _{PHL}				24	36		24	36		
t _{PHL}	Clear	Any		25	37		25	37		ns

^ff_{max} = maximum count frequency.

t_{PLH} = propagation delay time, low-to-high-level output.

t_{PHL} = propagation delay time, high to low level output.

NOTE 6: Load circuit, input conditions, and voltage waveforms are the same as those shown for the 1176, 1177 except that testing f_{max}, V_{IL} = 0.3 V.

TYPES SN54LS196, SN54LS197, SN74LS196, SN74LS197 30-MHz PRESETTABLE DECADE OR BINARY COUNTERS/LATCHES

schematics of inputs and outputs

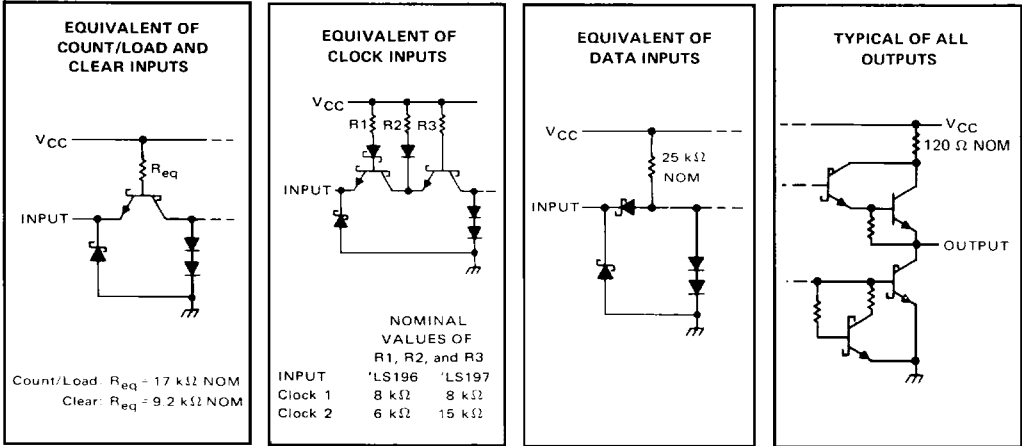

absolute maximum ratings over operating free-air temperature range (unless otherwise noted)

Supply voltage, V_{CC} (see Note 1)	7 V
Input voltage	5.5 V
Intermitter voltage (see Note 2)	5.5 V
Operating free air temperature range: SN54LS196, SN54LS197 Circuits	-55°C to 125°C
SN74LS196, SN74LS197 Circuits	0°C to 70°C
Storage temperature range	-65°C to 150°C

NOTES: 1. Voltage values are with respect to network ground terminal.

2. This is the voltage between two emitters of a multiple-emitter transistor. For this circuit, this rating applies between the clear and count/load inputs.

recommended operating conditions

		SN54LS196, SN54LS197			SN74LS196, SN74LS197			UNIT
		MIN	NOM	MAX	MIN	NOM	MAX	
V_{CC}	Supply voltage	4.5	5	5.5	4.75	5	5.25	V
I_{OH}	High-level output current			-400			-400	μA
I_{OL}	Low-level output current			4			8	mA
Count frequency	Clock-1 input	0		30	0		30	MHz
	Clock-2 input	0		15	0		15	
t_w	Pulse width	Clock-1 input		20		20		ns
		Clock-2 input		30		30		
		Clear		15		15		
		Load		20		20		
t_h	Input hold time	High-level data		10		10		ns
		Low-level data		10		10		
t_{su}	Input setup time	High-level data		10		10		ns
		Low-level data		15		15		
t_{enable}	Count enable time (see Note 3)	Clock 1		30		30		ns
		Clock 2		50		50		
T_A	Operating free-air temperature	-55		125	0		70	°C

NOTE 3: Minimum count enable time is the interval immediately preceding the negative-going edge of the clock pulse during which interval the count/load and clear inputs must both be high to ensure counting.

3

TTL DEVICES

TYPES SN54LS196, SN54LS197, SN74LS196, SN74LS197

30-MHz PRESETTABLE DECADE OR BINARY COUNTERS/LATCHES

electrical characteristics over recommended operating free-air temperature range (unless otherwise noted)

PARAMETER		TEST CONDITIONS†	SN54LS196			SN74LS196			UNIT
			SN54LS197			SN74LS197			
			MIN	TYP‡	MAX	MIN	TYP‡	MAX	
V _{IH}	High-level input voltage		2			2			V
V _{IL}	Low-level input voltage		0.7			0.8			V
V _{IK}	Input clamp voltage	V _{CC} = MIN, I _I = -18 mA	-1.5			-1.5			V
V _{OH}	High-level output voltage	V _{CC} = MIN, V _{IH} = 2 V, V _{IL} = V _{IL max} , I _{OH} = -400 µA	2.5	3.4		2.7	3.4		V
V _{OL}	Low-level output voltage	V _{CC} = MIN, V _{IH} = 2 V, V _{IL} = V _{IL max}	I _{OL} = 4 mA‡ I _{OL} = 8 mA‡			0.25 0.4 0.25 0.4 0.35 0.5			V
I _I	Input current at maximum input voltage	Data, count/load	V _{CC} = MAX, V _I = 5.5 V			0.1			mA
		Clear, clock 1				0.2			
		Clock 2 of 'LS196				0.4			
		Clock 2 of 'LS197				0.2			
I _{IH}	High-level input current	Data, count/load	V _{CC} = MAX, V _I = 2.7 V			20			µA
		Clear, clock 1				40			
		Clock 2 of 'LS196				80			
		Clock 2 of 'LS197				40			
I _{IL}	Low-level input current	Data, count/load	V _{CC} = MAX, V _I = 0.4 V			-0.4			mA
		Clear				-0.8			
		Clock 1				-2.4			
		Clock 2 of 'LS196				-2.8			
		Clock 2 of 'LS197				-1.3			
I _{OS}	Short-circuit output current§	V _{CC} = MAX	-20	-100		-20	-100		mA
I _{CC}	Supply current	V _{CC} = MAX, See Note 4	16	27		16	27		mA

† For conditions shown as MIN or MAX, use the appropriate value specified under recommended operating conditions.

‡ All typical values are at V_{CC} = 5 V, T_A = 25°C.

§ Not more than one output should be shorted at a time, and duration of the short-circuit should not exceed one second.

¶ Q_A outputs are tested at specified I_{OL} plus the limit value of I_{IL} for the clock 2 input. This permits driving the clock 2 input while maintaining full fan out capability.

NOTE 4: I_{CC} is measured with all inputs grounded and all outputs open.

switching characteristics, V_{CC} = 5 V, T_A = 25°C

PARAMETER	FROM (INPUT)	TO (OUTPUT)	TEST CONDITIONS	SN54LS196			SN54LS197			UNIT
				SN74LS196			SN74LS197			
				MIN	TYP	MAX	MIN	TYP	MAX	
f _{max}	Clock 1	Q _A	C _L = 15 pF, R _L = 2 kΩ, See Note 5	30	40		30	40		MHz
t _{PLH}	Clock 1	Q _A		8	15		8	15		ns
t _{PHL}				13	20		14	21		
t _{PLH}	Clock 2	Q _B		16	24		12	19		ns
t _{PHL}				22	33		23	35		
t _{PLH}	Clock 2	Q _C		38	57		34	51		ns
t _{PHL}				41	62		42	63		
t _{PLH}	Clock 2	Q _D		12	18		55	78		ns
t _{PHL}				30	45		63	95		
t _{PLH}	A, B, C, D	Q _A , Q _B , Q _C , Q _D		20	30		18	27		ns
t _{PHL}				29	44		29	44		
t _{PLH}	Load	Any		27	41		26	39		ns
t _{PHL}				30	45		30	45		
t _{PHL}	Clear	Any		34	51		34	51		ns

f_{max} = maximum count frequency

t_{PLH} = propagation delay time, low-to-high-level output, t_{PHL} = propagation delay time, high-to-low-level output

NOTE 5: Load circuit, input conditions, and voltage waveforms are the same as those shown for the '176, '177 except that t_r ≤ 15 ns, t_f ≤ 6 ns, and V_{ref} = 1.3 V (as opposed to 1.5 V)

TYPES SN54S196, SN54S197, SN74S196, SN74S197 100-MHz PRESETTABLE DECADE AND BINARY COUNTERS/LATCHES

schematics of inputs and outputs

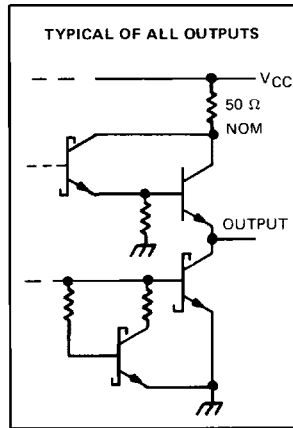
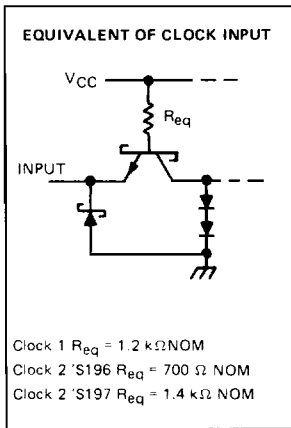
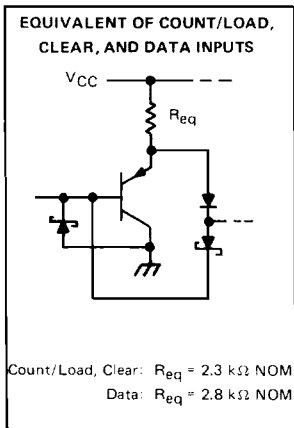

absolute maximum ratings over operating free-air temperature range (unless otherwise noted)

Supply voltage, V_{CC} (see Note 1)	7 V
Input voltage	5.5 V
Operating free-air temperature range: SN54S196, SN54S197 Circuits	-55°C to 125°C
SN74S196, SN74S197 Circuits	0°C to 70°C
Storage temperature range	-65°C to 150°C

NOTE 1: Voltage values are with respect to network ground terminal.

recommended operating conditions

		SN54S196, SN54S197			SN74S196, SN74S197			UNIT		
		MIN	NOM	MAX	MIN	NOM	MAX			
Supply voltage, V_{CC}		4.5	5	5.5	4.75	5	5.25	V		
High-level output current, I_{OH}		-1			-1			mA		
Low-level output current, I_{OL}		20			20			mA		
Clock frequency	Clock-1 input	0		100	0		100	MHz		
	Clock-2 input	0		50	0		50			
Pulse width, t_w	Clock-1 input	5			5			ns		
	Clock-2 input	10			10					
	Clear	30			30					
	Load	5			5					
Input hold time, t_h	High-level data	3†			3†			ns		
	Low-level data	3†			3†					
Input setup time, t_{SU} (see Note 6)	High-level data	6†			6†			ns		
	Low-level data	6†			6†					
Count enable time, t_{EN} (see Note 2)		12			12			ns		
Operating free-air temperature, T_A		-55			125			0	70	°C

NOTES: 2. Minimum count enable time is the interval immediately preceding the negative-going edge of the clock pulse during which interval the count/load and clear inputs are both high to permit counting.

6. t_{SU} is measured with respect to load input.

3

TTL DEVICES

TYPES SN54S196, SN54S197, SN74S196, SN74S197

100-MHz PRESETTABLE DECADE AND BINARY COUNTERS/LATCHES

electrical characteristics over recommended operating free-air temperature range (unless otherwise noted)

PARAMETER	TEST CONDITIONS †	SN54S196, SN74S196			SN54S197, SN74S197			UNIT
		MIN	TYP ‡	MAX	MIN	TYP ‡	MAX	
V _{IH}		2			2			V
V _{IL}		0.8			0.8			V
V _{IK}	V _{CC} = MIN, I _I = -18 mA	-1.2			-1.2			V
V _{OH}	V _{CC} = MIN, V _{IH} = 2 V, V _{IL} = 0.8 V, I _{OH} = -1 mA	54S	2.5	3.4	2.5	3.4	V	
		74S	2.7	3.4	2.7	3.4		
V _{OL}	V _{CC} = MIN, V _{IH} = 2 V, V _{IL} = 0.8 V, I _{OL} = 20 mA †	0.5			0.5			V
I _I	V _{CC} = MAX, V _I = 5.5 V	1			1			mA
I _{IH}	V _{CC} = MAX, V _I = 2.7 V	150			150			µA
		50			50			
I _{IL}	Data, count/load Clear	-0.75			-0.75			mA
	Clock 1	-8			-8			mA
	Clock 2	-10			-6			mA
I _{OS} §	V _{CC} = MAX	-30	-110	-30	-110	mA		
I _{CC}	V _{CC} = MAX, See Note 3	54S	75	110	75	110	mA	
		74S	75	120	75	120		

† For conditions shown as MIN or MAX, use the appropriate value specified under recommended operating conditions.

‡ All typical values are at V_{CC} = 5 V, T_A = 25°C.

†† Q_A outputs are tested at I_{OL} = 20 mA plus the limit value of I_{IL} for the clock-2 input. This permits driving the clock-2 input while fanning out to 10 Series 54S/74S loads.

§ Not more than one output should be shorted at a time, and duration of the short-circuit should not exceed one second.

NOTE 3: I_{CC} is measured with all inputs grounded and all outputs open.

3

TTL DEVICES

switching characteristics, V_{CC} = 5 V, T_A = 25°C

PARAMETER ◊	(FROM (INPUT))	TO (OUTPUT)	TEST CONDITIONS	SN54S196, SN74S196			SN54S197, SN74S197			UNIT
				MIN	TYP	MAX	MIN	TYP	MAX	
f _{max}	Clock 1	Q _A	R _L = 280 Ω, C _L = 15 pF, See Note 4	100	140		100	140		MHz
t _{PLH}	Clock 1	Q _A		5	10		5	10		ns
t _{PHL}				6	10		6	10		
t _{PLH}	Clock 2	Q _B		5	10		5	10		ns
t _{PHL}				8	12		8	12		
t _{PLH}	Clock 2	Q _C		12	18		12	18		ns
t _{PHL}				16	24		15	22		
t _{PLH}	Clock 2	Q _D		5	10		18	27		ns
t _{PHL}				8	12		22	33		
t _{PLH}	A,B,C,D	Q _A ,Q _B ,Q _C ,Q _D		7	12		7	12		ns
t _{PHL}				12	18		12	18		
t _{PLH}	Load	Any		10	18		10	18		ns
t _{PHL}				12	18		12	18		
t _{PHL}	Clear	Any		26	37		26	37		ns

◊ f_{max} = maximum input county frequency.

t_{PLH} = propagation delay time, low-to-high-level output.

t_{PHL} = propagation delay time, high-to-low-level output.

NOTE 4: See General Information Section for load circuits and voltage waveforms.