

SBD Type : FRH20A18

OUTLINE DRAWING

20A 180V Tj:150°C
FEATURES

- *Similar to TO-220AB Case
- *Fully Molded Isolation
- *Dual Diodes – Anode Common
- *High Voltage Low Leakage Current
- *Low Forward Voltage Drop
- *Low Power Loss,High Efficiency
- *Tj=150 °C operation

APPLICATIONS

- *For Replacement of 200V FRD
(Low Noise, High Efficiency power Supply)

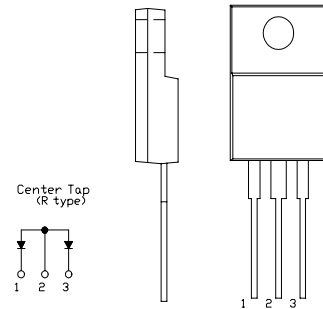
Maximum Ratings

Approx Net Weight: 1.75g

Rating	Symbol	FRH20A18			Unit
Repetitive Peak Reverse Voltage	V_{RRM}	180			V
Average Rectified Output Current	I_O	20	$T_c=119^\circ\text{C}$	50 Hz Full Sine Wave Resistive Load	A
RMS Forward Current	$I_{F(RMS)}$	22.2			A
Surge Forward Current	I_{FSM}	120	50Hz Full Sine Wave ,1cycle Non-repetitive		A
Operating JunctionTemperature Range	T_{jw}	-40 to +150			°C
Storage Temperature Range	T_{stg}	-40 to +150			°C
Mounting torque	Ftor	recommended torque = 0.5			N•m

Electrical • Thermal Characteristics

Characteristics	Symbol	Conditions	Min.	Typ.	Max.	Unit
Peak Reverse Current	I_{RM}	$T_j= 25^\circ\text{C}$, $V_{RM}= V_{RRM}$ per Arm	-	-	200	μA
Peak Forward Voltage	V_{FM}	$T_j= 25^\circ\text{C}$, $I_{FM}= 10\text{ A}$ per Arm	-	-	0.90	V
Thermal Resistance	Rth(j-c)	Junction to Case	-	-	1.5	°C/W
	Rth(c-f)	Cace to Fin	-	-	1.5	°C/W

FRHxxA OUTLINE DRAWING (Dimensions in mm)

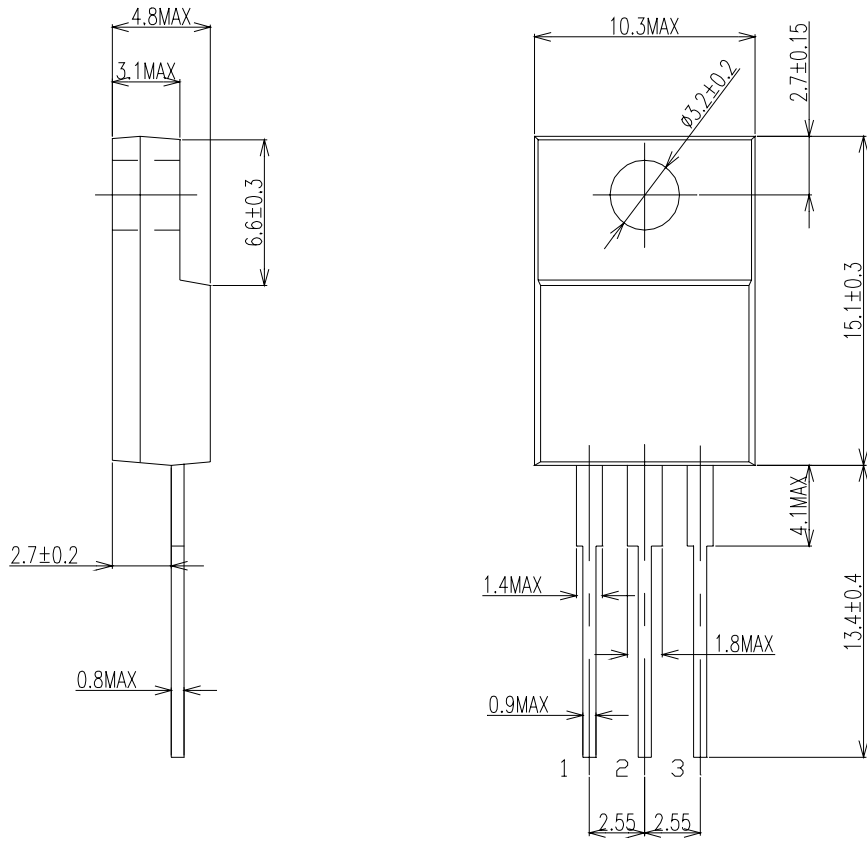

Center Tap
(R type)

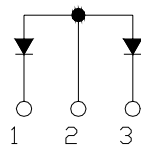

FORWARD CURRENT VS. VOLTAGE

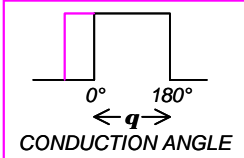
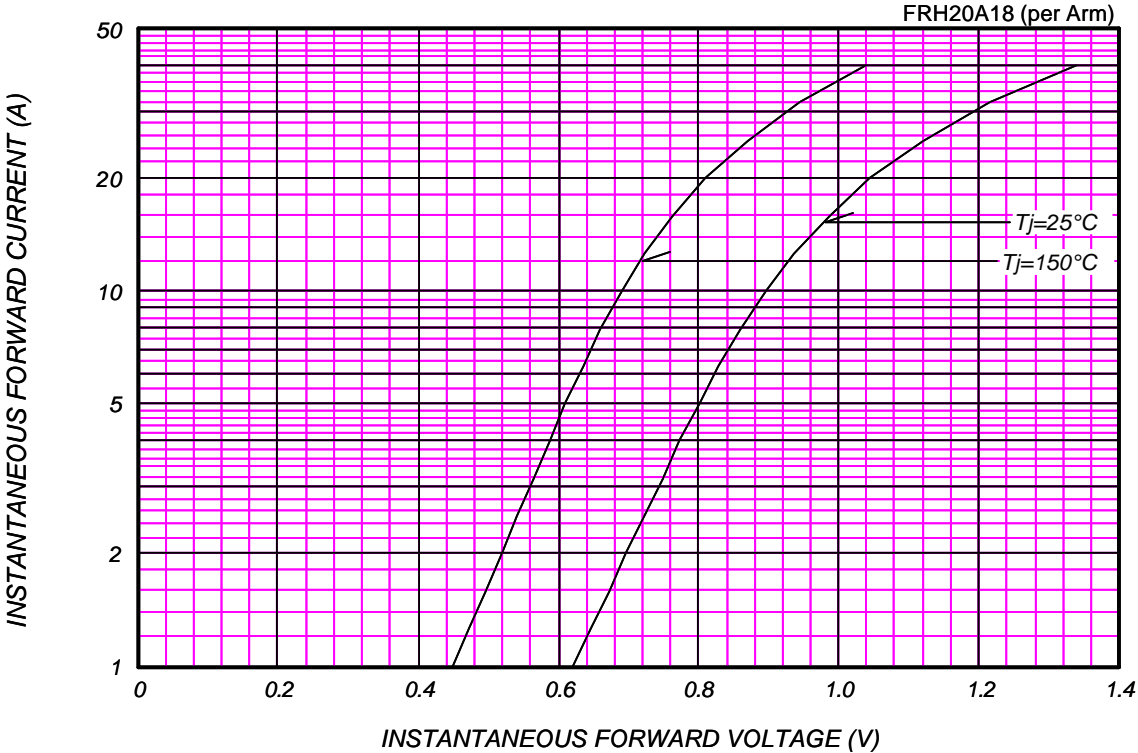

AVERAGE FORWARD POWER DISSIPATION

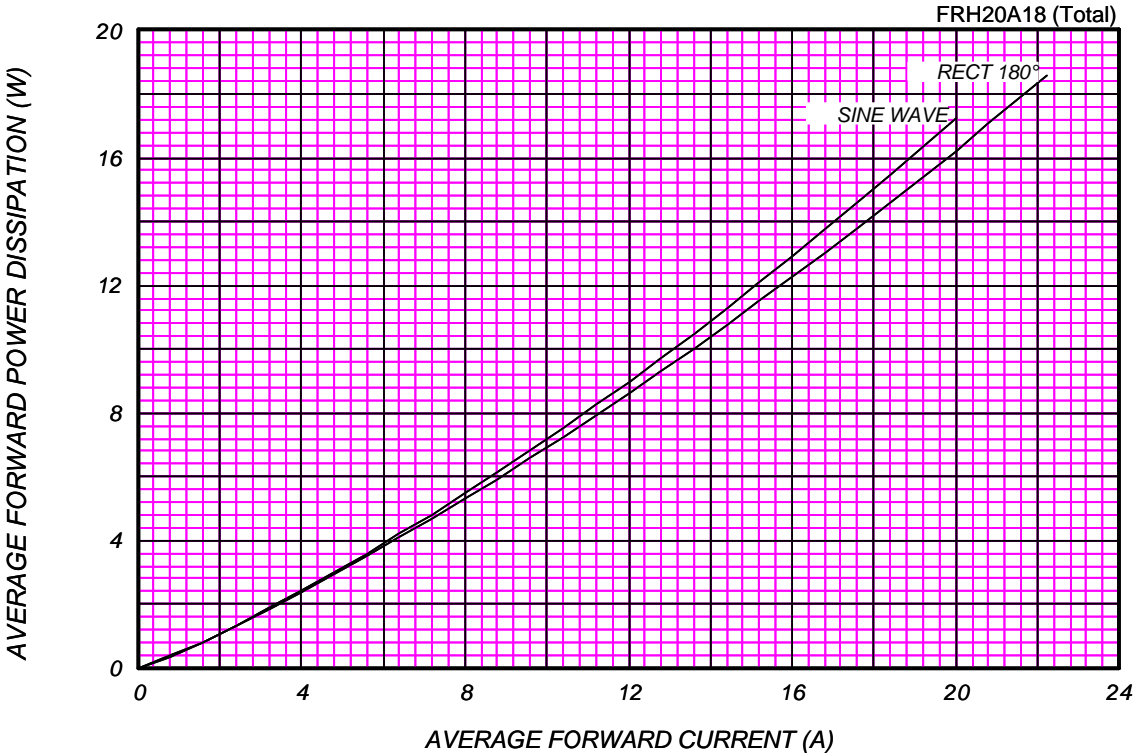

PEAK REVERSE CURRENT VS. PEAK REVERSE VOLTAGE

T_j = 150 °C

FRH20A18 (per Arm)

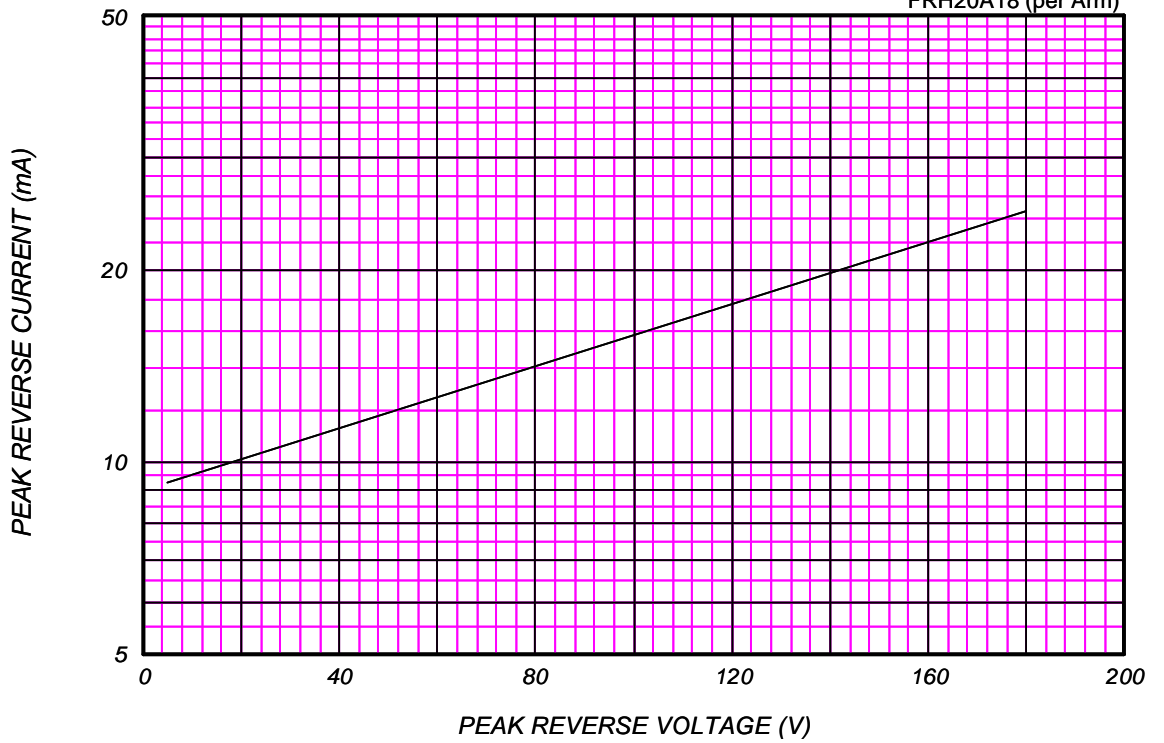

AVERAGE REVERSE POWER DISSIPATION

FRH20A18 (Total)

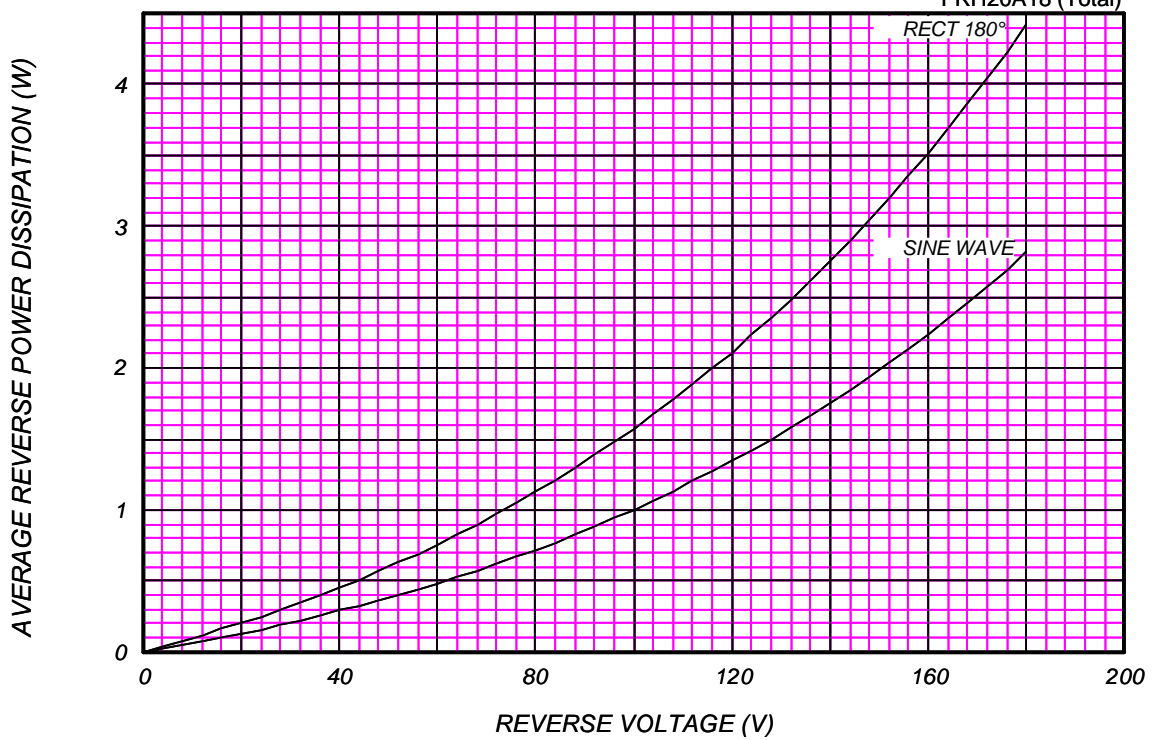

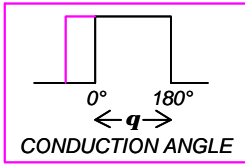

AVERAGE FORWARD CURRENT VS. CASE TEMPERATURE

$V_{RM} = 180V$

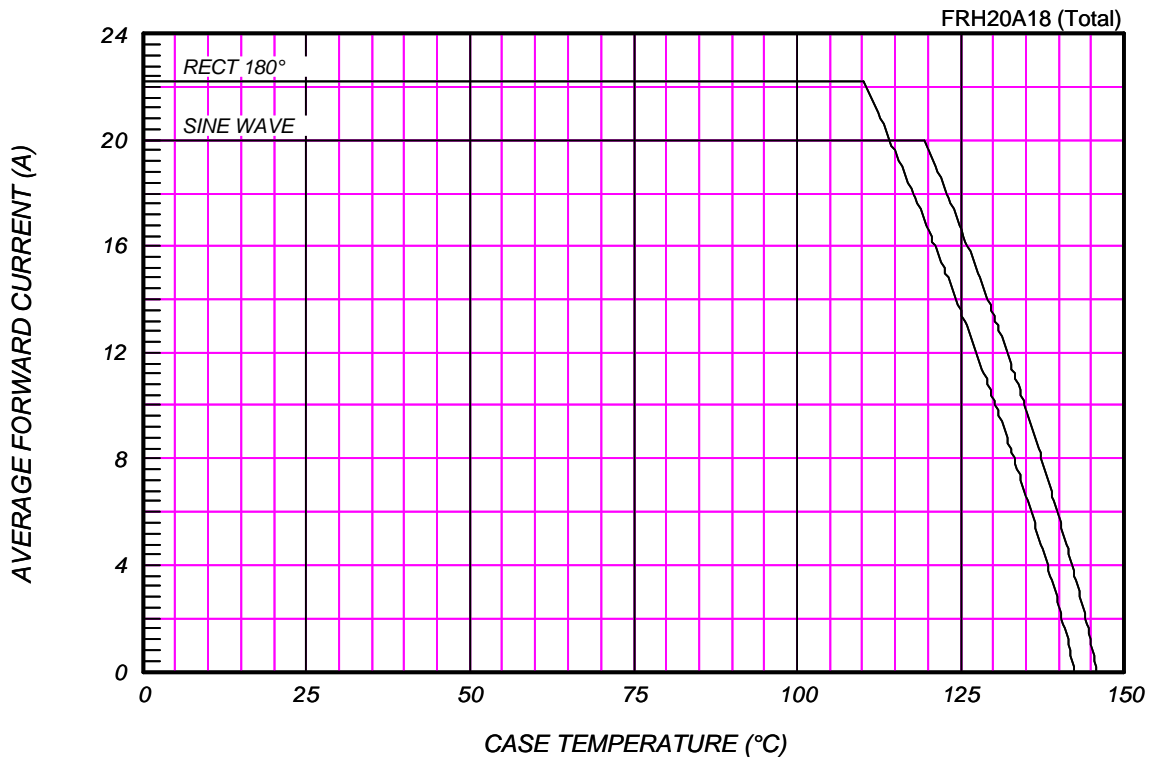

SURGE CURRENT RATINGS

$f = 50\text{Hz}$, Half Sine Wave, Non-Repetitive, No Load

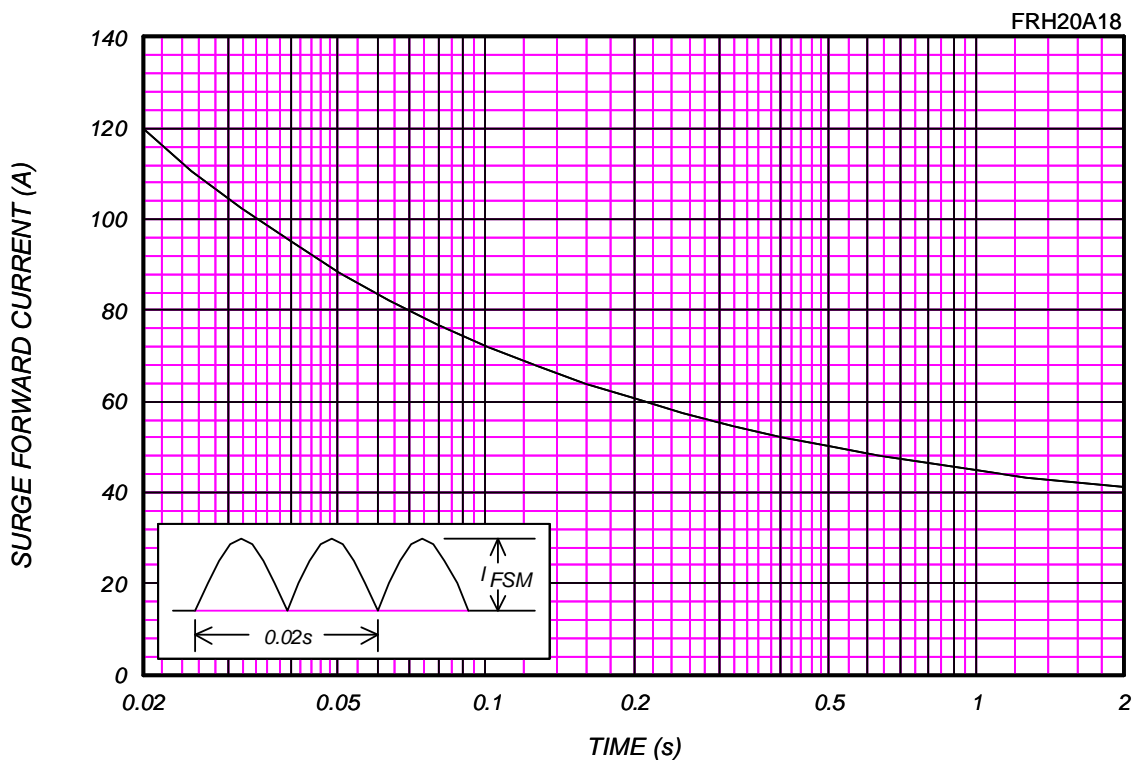

JUNCTION CAPACITANCE VS. REVERSE VOLTAGE

$T_J=25^\circ\text{C}$, $V_m=20\text{m}$ V_{RMS} , $f=100\text{kHz}$, Typical Value

FRH20A18 (per Arm)

