

National Semiconductor is now part of
Texas Instruments.

Search <http://www.ti.com/> for the latest technical
information and details on our current products and services.

LM185-2.5/LM285-2.5/LM385-2.5 Micropower Voltage Reference Diode

General Description

The LM185-2.5/LM285-2.5/LM385-2.5 are micropower 2-terminal band-gap voltage regulator diodes. Operating over a 20 μA to 20 mA current range, they feature exceptionally low dynamic impedance and good temperature stability. On-chip trimming is used to provide tight voltage tolerance. Since the LM-185-2.5 band-gap reference uses only transistors and resistors, low noise and good long term stability result.

Careful design of the LM185-2.5 has made the device exceptionally tolerant of capacitive loading, making it easy to use in almost any reference application. The wide dynamic operating range allows its use with widely varying supplies with excellent regulation.

The extremely low power drain of the LM185-2.5 makes it useful for micropower circuitry. This voltage reference can be used to make portable meters, regulators or general purpose analog circuitry with battery life approaching shelf life.

Further, the wide operating current allows it to replace older references with a tighter tolerance part. For applications requiring 1.2V see LM185-1.2.

The LM185-2.5 is rated for operation over a -55°C to 125°C temperature range while the LM285-2.5 is rated -40°C to 85°C and the LM385-2.5 0°C to 70°C . The LM185-2.5/LM285-2.5 are available in a hermetic TO-46 package and the LM285-2.5/LM385-2.5 are also available in a low-cost TO-92 molded package, as well as S.O. The LM185-2.5 is also available in a hermetic leadless chip carrier package.

Features

- ± 20 mV ($\pm 0.8\%$) max. initial tolerance (A grade)
- Operating current of 20 μA to 20 mA
- 0.6Ω dynamic impedance (A grade)
- Low temperature coefficient
- Low voltage reference—2.5V
- 1.2V device and adjustable device also available—LM185-1.2 series and LM185 series, respectively

Applications

Wide Input Range Reference

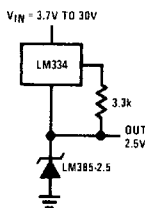

TL/H/5519-12

Micropower Reference from 9V Battery

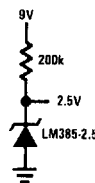

TL/H/5519-2

Connection Diagrams

TO-92 Plastic Package

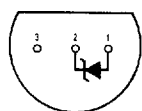

TL/H/5519-8

Bottom View

Order Number LM285Z-2.5,
LM285AZ-2.5, LM285AXZ-2.5,
LM285AYZ-2.5,
LM285BXZ-2.5, LM285BYZ-2.5,
LM385Z-2.5, LM385AZ-2.5,
LM385AXZ-2.5, LM385AYZ-2.5,
LM385BZ-2.5, LM385BXZ-2.5
or LM385BYZ-2.5
See NS Package Number Z03A

TO-46 Metal Can Package

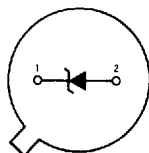

TL/H/5519-13

Bottom View

Order Number LM185H-2.5,
LM185H-2.5/883
LM185BXH-2.5, LM185BXH-2.5/883,
LM185BYH-2.5, LM185BYH-2.5/883,
LM285H-2.5, LM285BXH-2.5
or LM285BYH-2.5
See NS Package Number H02A

SO Package

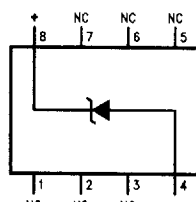

TL/H/5519-11

Order Number LM285M-2.5,
LM285AM-2.5, LM285AXM-2.5,
LM285AYM-2.5, LM285BXM-2.5,
LM285BYM-2.5, LM385M-2.5,
LM385AM-2.5, LM385AXM-2.5,
LM385AYM-2.5, LM385BM-2.5,
LM385BXM-2.5 or LM385BYM-2.5
See NS Package Number M08A

Absolute Maximum Ratings (Note 1)

If Military/Aerospace specified devices are required, please contact the National Semiconductor Sales Office/Distributors for availability and specifications. (Note 2)

Reverse Current	30 mA
Forward Current	10 mA
Operating Temperature Range (Note 3)	
LM185-2.5	-55°C to +125°C
LM285-2.5	-40°C to +85°C
LM385-2.5	0°C to 70°C

Storage Temperature	-55°C to +150°C
Soldering Information	
TO-92 Package (10 sec.)	260°C
TO-46 Package (10 sec.)	300°C
SO Package	
Vapor Phase (60 sec.)	215°C
Infrared (15 sec.)	220°C

See AN-450 "Surface Mounting Methods and Their Effect on Product Reliability" for other methods of soldering surface mount devices.

Electrical Characteristics (Note 4)

Parameter	Conditions	Typ	LM285A-2.5 LM285AX-2.5 LM285AY-2.5		LM385A-2.5 LM385AX-2.5 LM385AY-2.5		Units (Limits)
			Tested Limit (Notes 5, 8)	Design Limit (Note 6)	Tested Limit (Note 5)	Design Limit (Note 6)	
Reverse Breakdown Voltage	$I_R = 100 \mu A$	2.500 2.500	2.480 2.520	2.460 2.535	2.480 2.520	2.470 2.530	V(Min) V(Max) V(Min) V(Max)
Minimum Operating Current		12	18	20	18	20	μA (Max)
Reverse Breakdown Voltage Change with Current	$I_{MIN} \leq I_R \leq 1 mA$		1	1.5	1	1.5	mV (Max)
	$1 mA \leq I_R \leq 20 mA$		10	20	10	20	mV (Max)
Reverse Dynamic Impedance	$I_R = 100 \mu A$, $f = 20 Hz$	0.2		0.6 1.5		0.6 1.5	Ω
Wideband Noise (rms)	$I_R = 100 \mu A$ $10 Hz \leq f \leq 10 kHz$	120					μV
Long Term Stability	$I_R = 100 \mu A$, $T = 1000 Hr$, $T_A = 25^\circ C \pm 0.1^\circ C$	20					ppm
Average Temperature Coefficient (Note 7)	$I_{MIN} \leq I_R \leq 20 mA$ X Suffix Y Suffix All Others		30 50	150	30 50	150	ppm/°C (Max)

Electrical Characteristics (Continued) (Note 4)

LM185-2.5/LM285-2.5/LM385-2.5

Parameter	Conditions	Typ	LM185-2.5 LM185BX-2.5 LM185BY-2.5 LM285-2.5 LM285BX-2.5 LM285BY-2.5		LM385B-2.5 LM385BX-2.5 LM385BY-2.5		LM385-2.5		Units (Limit)
			Tested Limit (Notes 5, 8)	Design Limit (Note 6)	Tested Limit (Note 5)	Design Limit (Note 6)	Tested Limit (Note 5)	Design Limit (Note 6)	
Reverse Breakdown Voltage	$T_A = 25^\circ\text{C}$, $20 \mu\text{A} \leq I_R \leq 20 \text{ mA}$	2.5	2.462 2.538		2.462 2.538		2.425 2.575		V(Min) V(Max)
Minimum Operating Current		13	20	30	20	30	20	30	μA (Max)
Reverse Breakdown Voltage Change with Current	$20 \mu\text{A} \leq I_R \leq 1 \text{ mA}$		1	1.5	2.0	2.5	2.0	2.5	mV (Max)
	$1 \text{ mA} \leq I_R \leq 20 \text{ mA}$		10	20	20	25	20	25	mV (Max)
Reverse Dynamic Impedance	$I_R = 100 \mu\text{A}$, $f = 20 \text{ Hz}$	1							Ω
Wideband Noise (rms)	$I_R = 100 \mu\text{A}$, $10 \text{ Hz} \leq f \leq 10 \text{ kHz}$	120							μV
Long Term Stability	$I_R = 100 \mu\text{A}$, $T = 1000 \text{ Hr}$, $T_A = 25^\circ\text{C} \pm 0.1^\circ\text{C}$	20							ppm
Average Temperature Coefficient (Note 7)	$I_R = 100 \mu\text{A}$								ppm/ $^\circ\text{C}$
	X Suffix		30		30				ppm/ $^\circ\text{C}$
	Y Suffix All Others		50	150	50	150		150	ppm/ $^\circ\text{C}$ (Max)

Note 1: Absolute Maximum Ratings indicate limits beyond which damage to the device may occur. Operating Ratings indicate conditions for which the device is intended to be functional, but do not guarantee specific performance limits. For guaranteed specifications and test conditions, see the Electrical Characteristics. The guaranteed specifications apply only for the test conditions listed.

Note 2: Refer to RETS185H-2.5 for military specifications.

Note 3: For elevated temperature operation, $T_{J \text{ MAX}}$ is:

LM185	150 $^\circ\text{C}$
LM285	125 $^\circ\text{C}$
LM385	100 $^\circ\text{C}$

Thermal Resistance	TO-92	TO-46	SO-8
θ_{JA} (Junction to Ambient)	180 $^\circ\text{C}/\text{W}$ (0.4" Leads) 170 $^\circ\text{C}/\text{W}$ (0.125" Leads)	440 $^\circ\text{C}/\text{W}$	165 $^\circ\text{C}/\text{W}$
θ_{JA} (Junction to Case)	N/A	80 $^\circ\text{C}/\text{W}$	N/A

Note 4: Parameters identified with **boldface type** apply at temperature extremes. All other numbers apply at $T_A = T_J = 25^\circ\text{C}$.

Note 5: Guaranteed and 100% production tested.

Note 6: Guaranteed, but not 100% production tested. These limits are not used to calculate average outgoing quality levels.

Note 7: The average temperature coefficient is defined as the maximum deviation of reference voltage at all measured temperatures between the operating T_{MAX} and T_{MIN} , divided by $T_{MAX} - T_{MIN}$. The measured temperatures are -55°C , -40°C , 0°C , 25°C , 70°C , 85°C , 125°C .

Note 8: A military RETS electrical specification available on request.

4

Typical Performance Characteristics

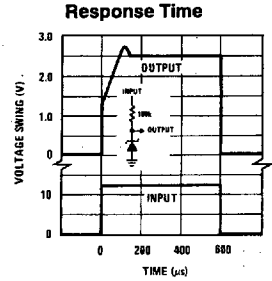
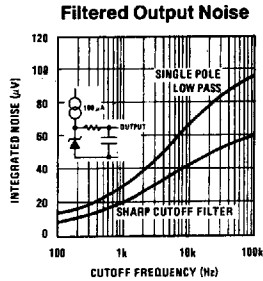
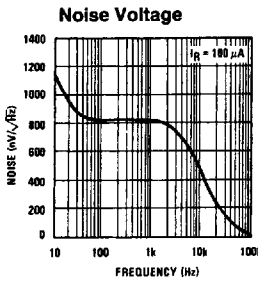
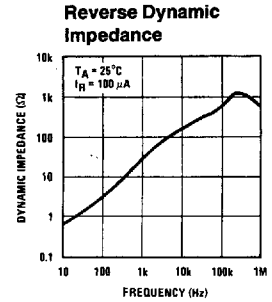
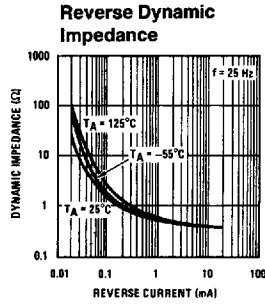
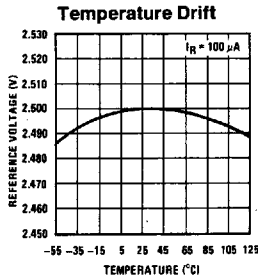
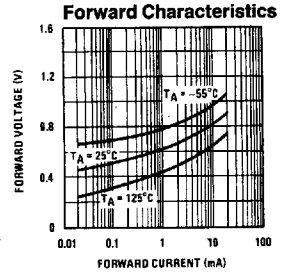
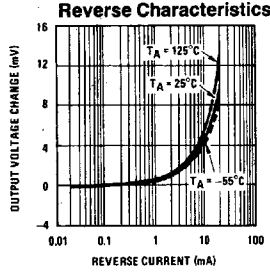
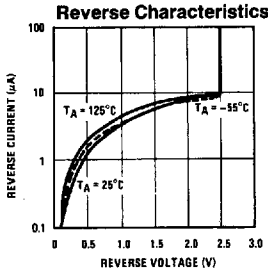

TL/H/5519-3

Connection Diagram

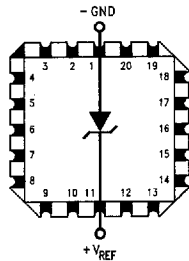

TL/H/5519-14

Order Number LM185E-2.5/883
See NS Package Number E20A

LM385-2.5 Applications

Micropower* 5V Regulator

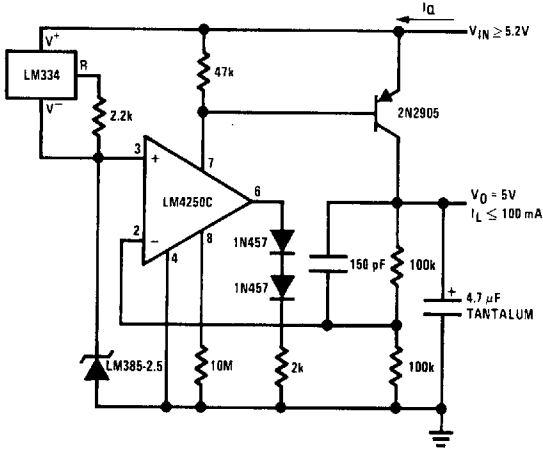

* $I_Q = 40 \mu A$

TL/H/5519-9

Micropower* 10V Reference

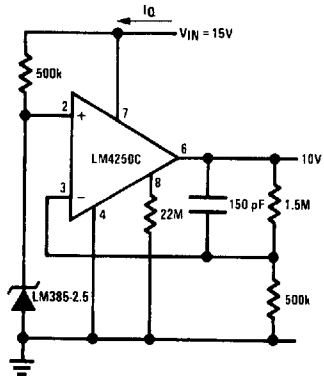

TL/H/5519-10

* $I_Q = 30 \mu A$ standby current

Precision 1µA to 1mA Current Sources

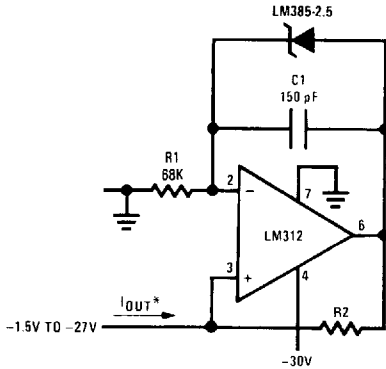

$$I_{OUT} = \frac{2.5V}{R_2}$$

TL/H/5519-4

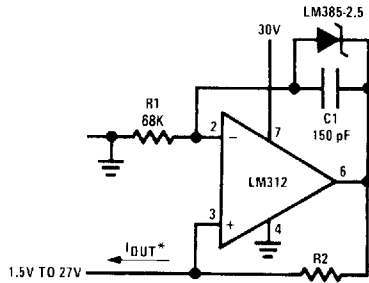

METER THERMOMETERS

0°C–100°C Thermometer

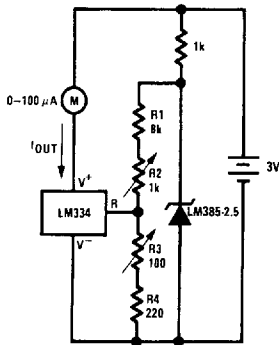

Calibration

1. Short LM385-2.5, adjust R3 for $I_{OUT} = \text{temp at } 1 \mu A/^{\circ}K$
2. Remove short, adjust R2 for correct reading in centigrade

0°F–50°F Thermometer

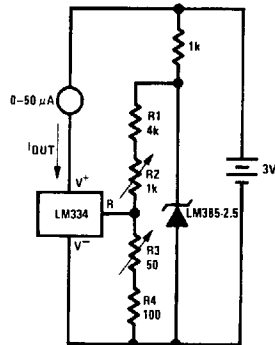

Calibration

1. Short LM385-2.5, adjust R3 for $I_{OUT} = \text{temp at } 1.8 \mu A/^{\circ}K$
2. Remove short, adjust R2 for correct reading in °F

TL/H/5519-5

LM385-2.5 Applications (Continued)

Micropower Thermocouple Cold Junction Compensator

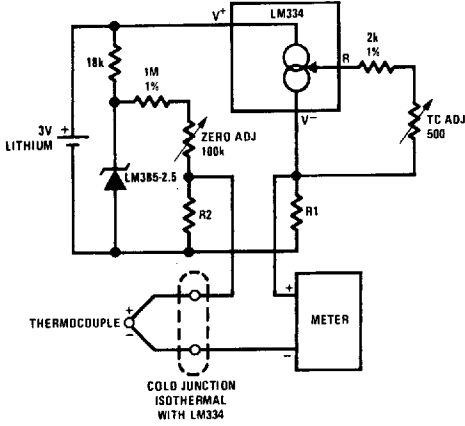

Adjustment Procedure

1. Adjust TC ADJ pot until voltage across R1 equals Kelvin temperature multiplied by the thermocouple Seebeck coefficient.
2. Adjust zero ADJ pot until voltage across R2 equals the thermocouple Seebeck coefficient multiplied by 273.2.

TL/H/5519-6

Thermocouple Type	Seebeck Co-efficient ($\mu\text{V}/^\circ\text{C}$)	R1 (Ω)	R2 (Ω)	Voltage Across R1 @ 25°C (mV)	Voltage Across R2 (mV)
J	52.3	523	1.24k	15.60	14.32
T	42.8	432	1k	12.77	11.78
K	40.8	412	953 Ω	12.17	11.17
S	6.4	63.4	150 Ω	1.908	1.766

Typical supply current 50 μA

Improving Regulation of Adjustable Regulators

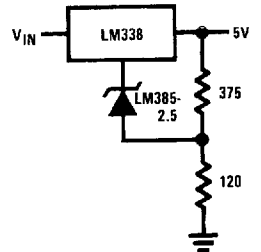

TL/H/5519-7

Schematic Diagram

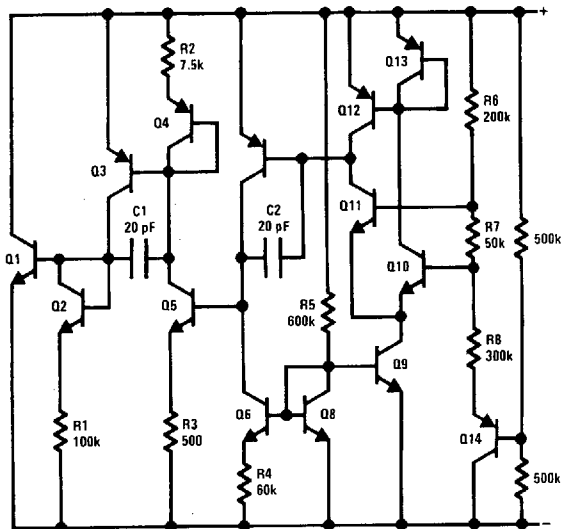

TL/H/5519-1