

8K x 8 SRAM

SRAM MEMORY ARRAY

AVAILABLE AS MILITARY SPECIFICATIONS

- SMD 5962-38294
- MIL-STD-883

FEATURES

- High Speed: 12, 15, 20, 25, 35, 45, 55, and 70ns
- Battery Backup: 2V data retention
- High-performance, low-power CMOS double-metal process
- Single +5V ($\pm 10\%$) Power Supply
- Easy memory expansion with CE1\ and CE2
- All inputs and outputs are TTL compatible

OPTIONS

• Timing

12ns access	-12
15ns access	-15
20ns access	-20
25ns access	-25
35ns access	-35
45ns access	-45
55ns access	-55*
70ns access	-70*

• Package(s)

Ceramic DIP (300 mil)	C	No. 108
Ceramic LCC	E C	No. 204
Ceramic Flatpack	F	No. 302

• Operating Temperature Ranges

Industrial (-40°C to +85°C)	IT
Military (-55°C to +125°C)	XT

- 2V data retention/low power L

*Electrical characteristics identical to those provided for the 45ns access devices.

**For more products and information
please visit our web site at
www.micross.com**

PIN ASSIGNMENT (Top View)

28-Pin DIP (C)
(300 MIL)

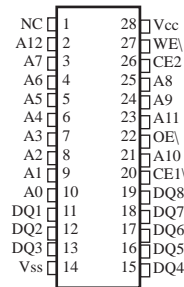

28-Pin LCC (EC)

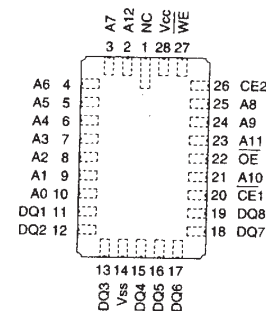

28-Pin Flat Pack (F)

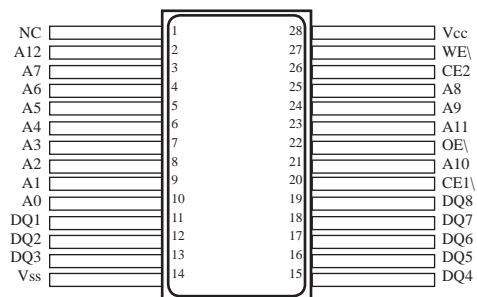

GENERAL DESCRIPTION

The MT5C6408, 8K x 8 SRAM, employs high-speed, low-power CMOS technology, eliminating the need for clocks or refreshing. These SRAM's have equal access and cycle times.

For flexibility in high-speed memory applications, Micross Components offers dual chip enables (CE1\, CE2) and output enable (OE\) capability. These enhancements can place the outputs in High-Z for additional flexibility in system design.

Writing to these devices is accomplished when write enable (WE\) and CE1\ inputs are both LOW and CE2 is HIGH. Reading is accomplished when WE\ and CE2 remain HIGH and CE1\ and OE\ go LOW. The device offers a reduced power standby mode when disabled. This allows system designs to achieve low standby power requirements.

These devices operate from a single +5V power supply and all inputs and outputs are fully TTL compatible.



FUNCTIONAL BLOCK DIAGRAM

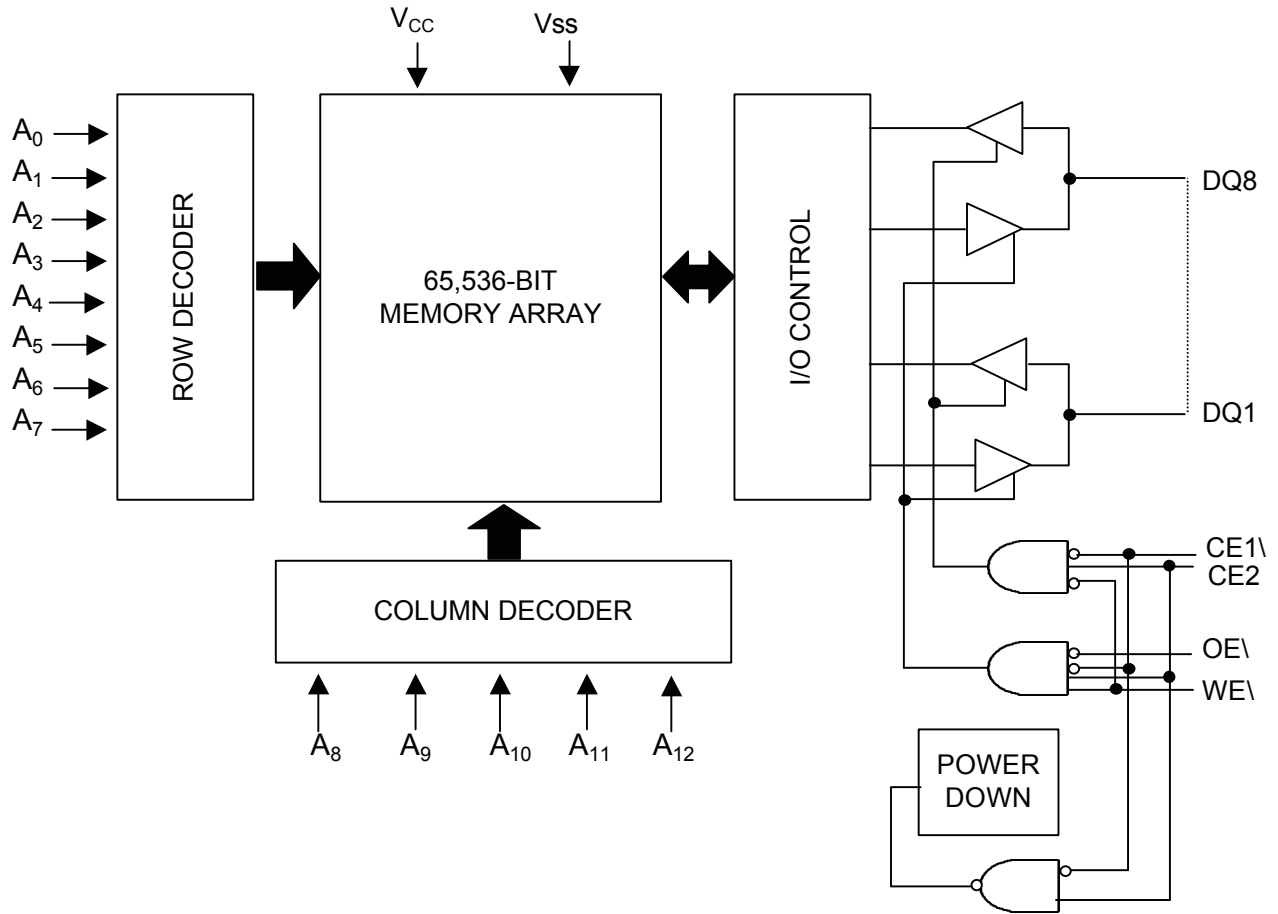

TRUTH TABLE

MODE	CE1\	CE2	WE\	OE\	DQ	POWER
STANDBY	H	X	X	X	HIGH-Z	STANDBY
STANDBY	X	L	X	X	HIGH-Z	STANDBY
READ	L	H	H	L	Q	ACTIVE
READ	L	H	H	H	HIGH-Z	ACTIVE
WRITE	L	H	L	X	D	ACTIVE

ABSOLUTE MAXIMUM RATINGS*

Voltage on any Input or DQ Relative to V _{ss}	-0.5V to +7.0V
Voltage on V _{cc} Supply Relative to V _{ss}	-0.5V to +7.0V
Storage Temperature.....	-65°C to +150°C
Power Dissipation.....	1W
Max Junction Temperature.....	+175°C
Lead Temperature (soldering 10 seconds).....	+260°C
Short Circuit Output Current.....	50mA

*Stresses greater than those listed under “Absolute Maximum Ratings” may cause permanent damage to the device. This is a stress rating only and functional operation of the device at these or any other conditions above those indicated in the operation section of this specification is not implied. Exposure to absolute maximum rating conditions for extended periods may affect reliability.

ELECTRICAL CHARACTERISTICS AND RECOMMENDED DC OPERATING CONDITIONS

(-55°C ≤ T_c ≤ 125°C; V_{cc} = 5V ±10%)

DESCRIPTION	CONDITIONS	SYMBOL	MIN	MAX	UNITS	NOTES
Input High (Logic 1) Voltage		V _{IH}	2.2	V _{cc} +0.5	V	1
Input Low (Logic 0) Voltage		V _{IL}	-0.5	0.8	V	1, 2
Input Leakage Current	0V ≤ V _{IN} ≤ V _{cc}	I _{LI}	-10	10	μA	
Output Leakage Current	Output(s) disabled 0V ≤ V _{OUT} ≤ V _{cc}	I _{LO}	-10	10	μA	
Output High Voltage	I _{OH} = -4.0mA	V _{OH}	2.4		V	1
Output Low Voltage	I _{OL} = 8.0mA	V _{OL}		0.4	V	1

PARAMETER	CONDITIONS	SYM	MAX						UNITS	NOTES
			-12	-15	-20	-25	-35	-45		
Power Supply Current: Operating	CE ≤ V _{IL} ; V _{cc} = MAX f = MAX = 1/t _{RC} (MIN) Output Open	I _{CC}	180	170	160	155	155	145	mA	3
Power Supply Current: Standby	CE ≥ V _{IH} ; All Other Inputs ≤ V _{IL} or ≥ V _{IH} , V _{cc} = MAX f = 0 Hz	I _{SBTSP}	40	40	40	40	40	40	mA	
		I _{SBTLP}	30	30	30	30	30	30	mA	
	CE ≥ (V _{cc} - 0.2); V _{cc} = MAX All Other Inputs ≤ 0.2V or ≥ (V _{cc} - 0.2V), f = 0 Hz	I _{SBCSP}	20	20	20	20	20	20	mA	
		I _{SBCLP}	10	10	10	10	10	10	mA	

CAPACITANCE

DESCRIPTION	CONDITIONS	SYM	MAX	UNITS	NOTES
Input Capacitance	T _A = 25°C, f = 1MHz V _{cc} = 5V	C _I	6	pF	4
Output Capacitance		C _O	7	pF	4

ELECTRICAL CHARACTERISTICS AND RECOMMENDED AC OPERATING CONDITIONS

 (Note 5) ($-55^{\circ}\text{C} \leq T_c \leq 125^{\circ}\text{C}$; $V_{CC} = 5\text{V} \pm 10\%$)

DESCRIPTION	SYMBOL	-12		-15		-20		-25		-35		-45		UNITS	NOTES
		MIN	MAX	MIN	MAX	MIN	MAX	MIN	MAX	MIN	MAX	MIN	MAX		
READ CYCLE															
READ cycle time	t_{RC}	12		15		20		25		35		45		ns	
Address access time	t_{AA}		12		15		20		25		35		45	ns	
Chip Enable access time	t_{ACE}		12		15		20		25		35		45	ns	
Output hold from address change	t_{OH}	2		0		0		0		3		3		ns	
Chip Enable to output in Low-Z	t_{LZCE}	2		0		0		0		0		0		ns	7
Chip disable to output in High-Z	t_{HZCE}		7		10		15		15		15		25	ns	6, 7
Output Enable access time	t_{AOE}		8		12		15		15		15		20	ns	
Output Enable to output in Low-Z	t_{LZOE}	0		0		0		0		0		0		ns	
Output disable to output in High-Z	t_{HZOE}		7		10		15		15		30		40	ns	6
WRITE CYCLE															
WRITE cycle time	t_{WC}	12		15		20		25		35		45		ns	
Chip Enable to end of write	t_{CW}	10		13		15		20		30		40		ns	
Address valid to end of write	t_{AW}	10		13		15		20		30		40		ns	
Address setup time	t_{AS}	0		0		0		0		0		0		ns	
Address hold from end of write	t_{AH}	0		0		0		0		0		0		ns	
WRITE pulse width	t_{WP}	10		13		15		20		30		40		ns	
Data setup time	t_{DS}	7		10		12		15		15		20		ns	
Data hold time	t_{DH}	0		0		0		0		5		5		ns	
Write disable to output in Low-Z	t_{LZWE}	2		0		0		0		0		0		ns	7
Write Enable to output in High-Z	t_{HZWE}	0	7	0	10	0	10	0	15	0	15	0	25	ns	6, 7

AC TEST CONDITIONS

Input pulse levels	V _{SS} to 3.0V
Input rise and fall times	5ns
Input timing reference levels	1.5V
Output reference levels	1.5V
Output load	See Figures 1 and 2

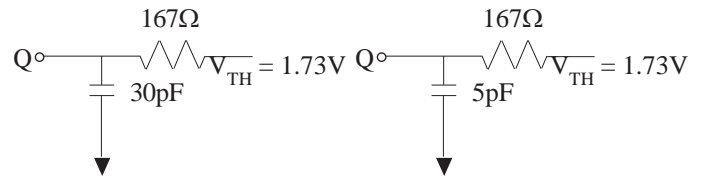

Fig. 1 Output Load Equivalent

Fig. 2 Output Load Equivalent

NOTES

- All voltages referenced to V_{SS} (GND).
- 3V for pulse width < 20ns
- I_{CC} is dependent on output loading and cycle rates. The specified value applies with the outputs unloaded, and $f = \frac{1}{RC (MIN)_}$ Hz.
- This parameter is guaranteed but not tested.
- Test conditions as specified with the output loading as shown in Fig. 1 unless otherwise noted.
- t_{LZCE}, t_{LZWE}, t_{LZOE}, t_{HZCE}, t_{HZOE} and t_{HZWE} are specified with CL = 5pF as in Fig. 2. Transition is measured ±200mV typical from steady state voltage, allowing for actual tester RC time constant.
- At any given temperature and voltage condition, t_{HZCE} is less than t_{LZCE}, and t_{HZWE} is less than t_{LZWE} and t_{HZOE} is less than t_{LZOE}.
- WE\ is HIGH for READ cycle.
- Device is continuously selected. Chip enables and output enables are held in their active state.
- Address valid prior to, or coincident with, latest occurring chip enable.
- 'RC = Read Cycle Time.
- CE2 timing is the same as CE1\ timing. The waveform is inverted.
- Chip enable (CE1\, CE2) and write enable (WE\) can initiate and terminate a WRITE cycle.

DATA RETENTION ELECTRICAL CHARACTERISTICS (L Version Only)

DESCRIPTION	CONDITIONS	SYM	MIN	MAX	UNITS	NOTES
V _{CC} for Retention Data		V _{DR}	2	---	V	
Data Retention Current	CE\ ≥ (V _{CC} - 0.2V) V _{IN} ≥ (V _{CC} - 0.2V) or ≤ 0.2V V _{CC} = 2V	I _{CCDR}		300	μA	
Chip Deselect to Data Retention Time		t _{CDR}	0	---	ns	4
Operation Recovery Time		t _R	t _{RC}		ns	4, 11

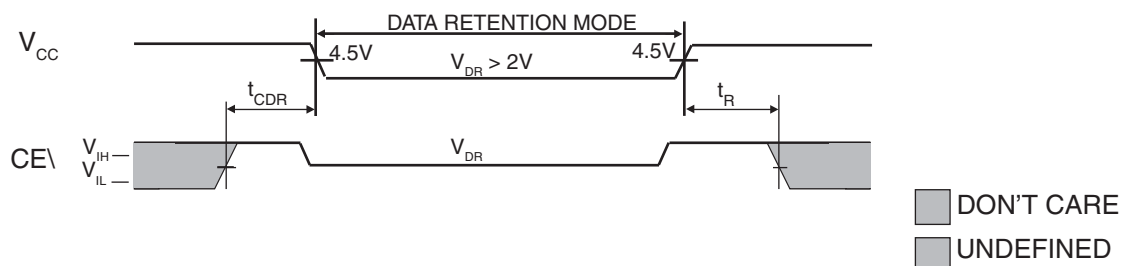
LOW V_{CC} DATA RETENTION WAVEFORM



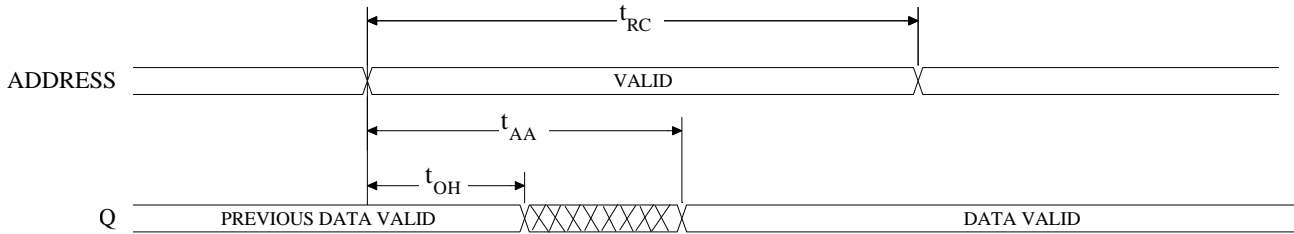

READ CYCLE NO. 1 ^{8,9}

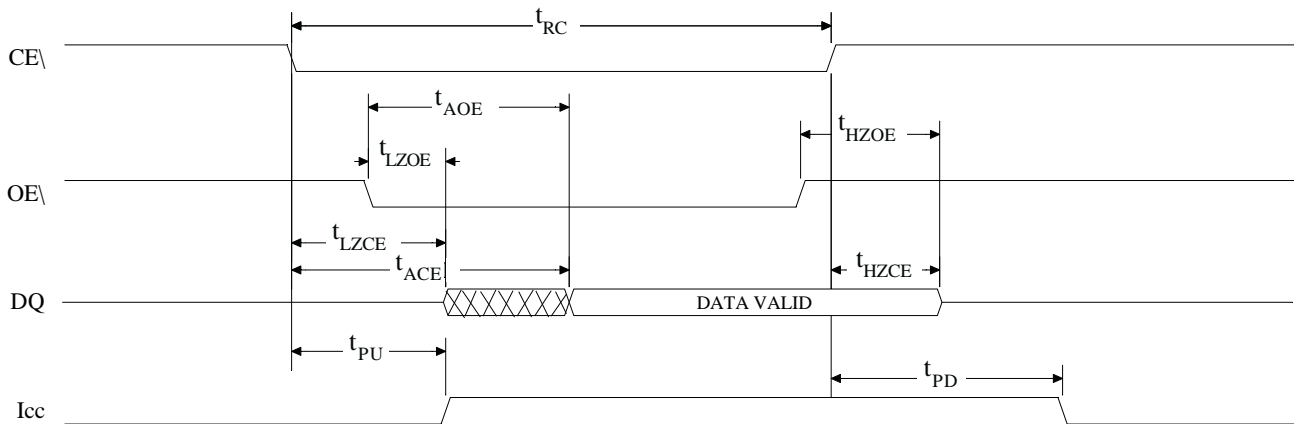

READ CYCLE NO. 2 ^{7, 8, 10, 12}



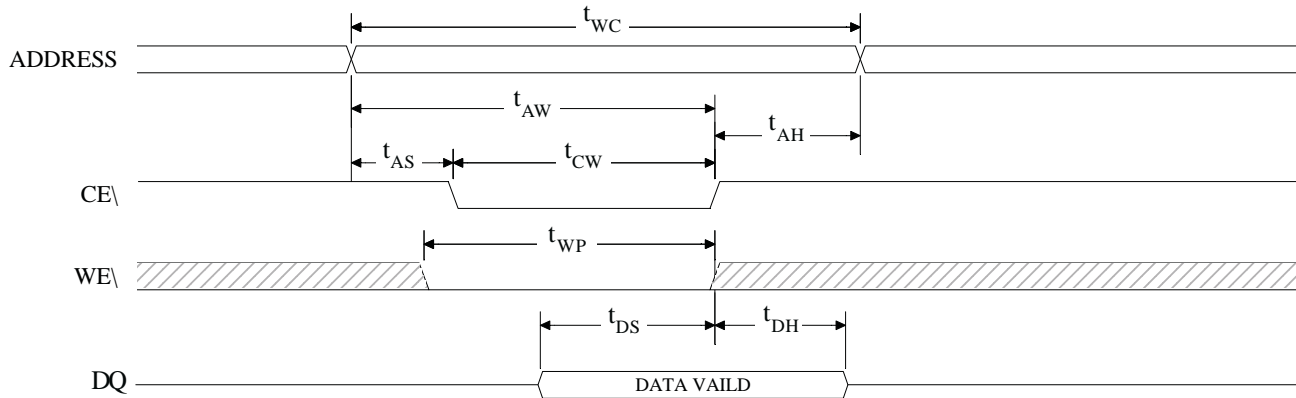

 DON'T CARE
 UNDEFINED

WRITE CYCLE NO. 1 ¹²
(Chip Enabled Controlled)

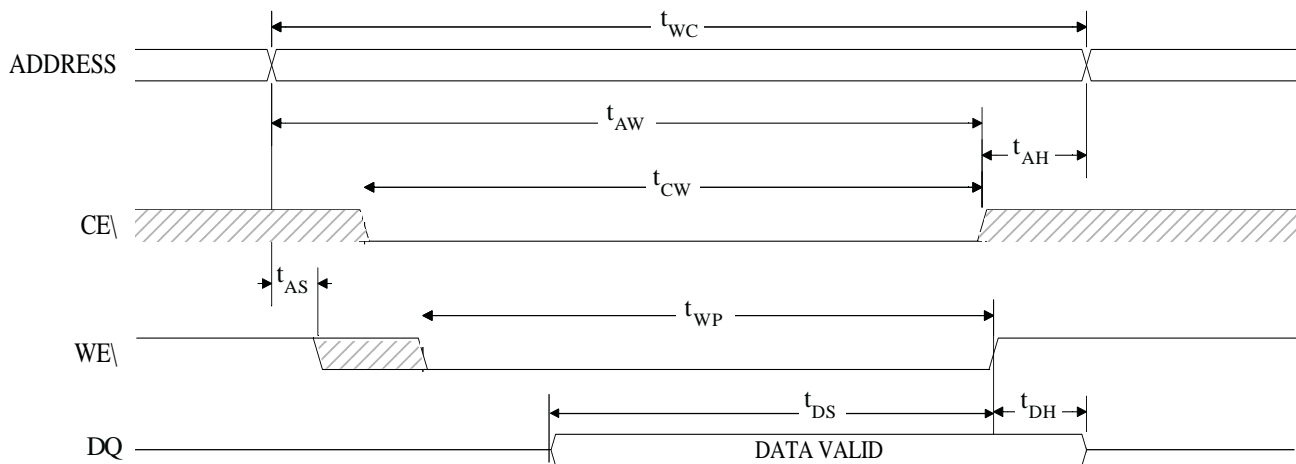

WRITE CYCLE NO. 2 ^{7, 12, 13}
(Write Enabled Controlled)



 DON'T CARE
 UNDEFINED

NOTE: Output enable (OE\) is inactive (HIGH).

MECHANICAL DEFINITIONS*

Micross Case #108 (Package Designator C)
SMD 5962-38294, Case Outline Z

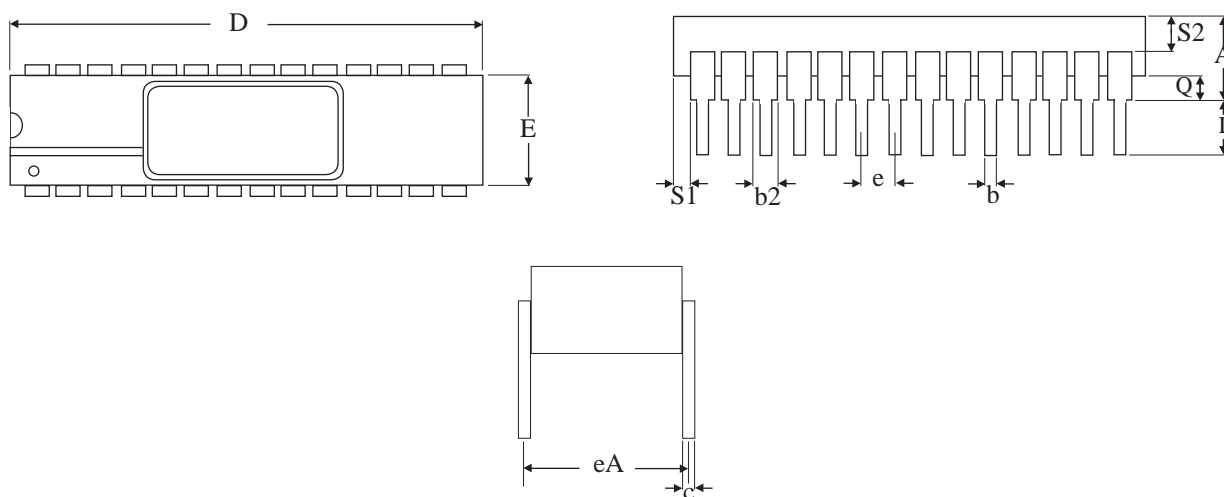

SYMBOL	SMD SPECIFICATIONS	
	MIN	MAX
A	---	0.225
b	0.014	0.026
b2	0.045	0.065
c	0.008	0.018
D	---	1.485
E	0.240	0.310
eA	0.300 BSC	
e	0.100 BSC	
L	0.125	0.200
Q	0.015	0.070
S1	0.005	---
S2	0.005	---

NOTE: *These dimensions are per the SMD. Micross' package dimensional limits may differ, but they will be within the SMD limits.*

* All measurements are in inches.



MECHANICAL DEFINITIONS*

Micross Case #204 (Package Designator EC)
SMD 5962-38294, Case Outline U

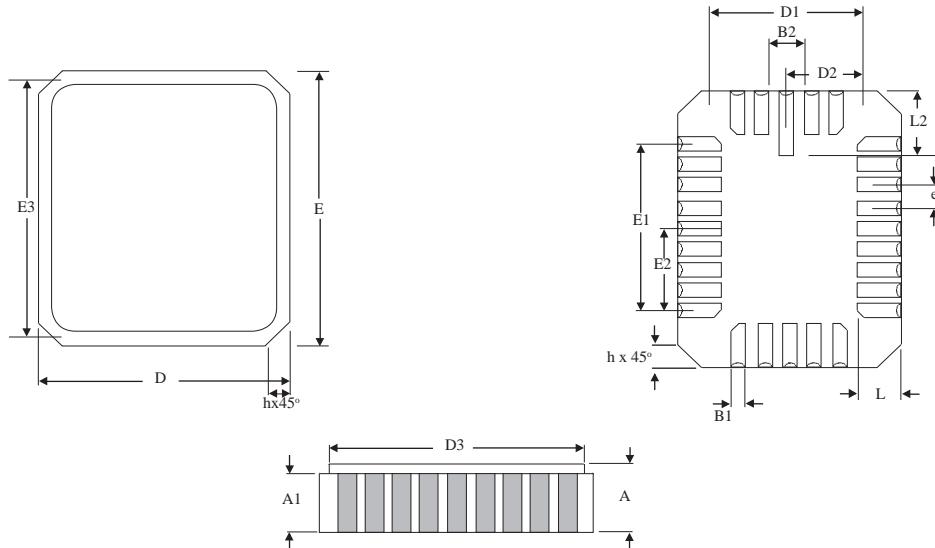

SYMBOL	SMD SPECIFICATIONS	
	MIN	MAX
A	0.060	0.075
A1	0.050	0.065
B1	0.022	0.028
B2	0.072 REF	
D	0.342	0.358
D1	0.200 BSC	
D2	0.100 BSC	
D3	---	0.358
E	0.540	0.560
E1	0.400 BSC	
E2	0.200 BSC	
E3	---	0.558
e	0.050 BSC	
h	0.040 REF	
L	0.045	0.055
L2	0.075	0.095

NOTE: These dimensions are per the SMD. Micross' package dimensional limits may differ, but they will be within the SMD limits.

* All measurements are in inches.

MECHANICAL DEFINITIONS*

Micross Case #302 (Package Designator F)
SMD 5962-38294, Case Outline M

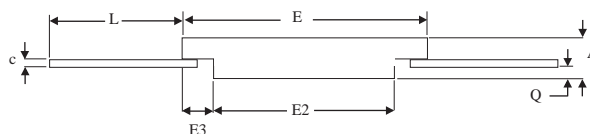
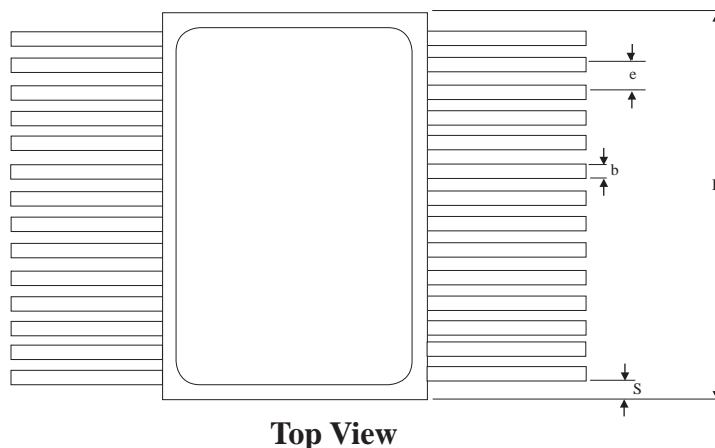

SYMBOL	SMD SPECIFICATIONS	
	MIN	MAX
A	0.045	0.115
b	0.015	0.019
c	0.004	0.009
D	---	0.640
E	0.350	0.420
E2	0.180	---
E3	0.030	---
e	0.050 BSC	
L	0.250	0.370
Q	0.026	0.045
S	0.000	---

NOTE: These dimensions are per the SMD. Micross' package dimensional limits may differ, but they will be within the SMD limits.

* All measurements are in inches.

ORDERING INFORMATION

EXAMPLE: MT5C6408C-25L/XT

Device Number	Package Type	Speed ns	Options**	Process
MT5C6408	C	-12	L	/*
MT5C6408	C	-15	L	/*
MT5C6408	C	-20	L	/*
MT5C6408	C	-25	L	/*
MT5C6408	C	-35	L	/*
MT5C6408	C	-45	L	/*
MT5C6408	C	-55	L	/*
MT5C6408	C	-70	L	/*

EXAMPLE: MT5C6408EC-15L/IT

Device Number	Package Type	Speed ns	Options**	Process
MT5C6408	EC	-12	L	/*
MT5C6408	EC	-15	L	/*
MT5C6408	EC	-20	L	/*
MT5C6408	EC	-25	L	/*
MT5C6408	EC	-35	L	/*
MT5C6408	EC	-45	L	/*
MT5C6408	EC	-55	L	/*
MT5C6408	EC	-70	L	/*

EXAMPLE: MT5C6408F-55/883C

Device Number	Package Type	Speed ns	Options**	Process
MT5C6408	F	-12	L	/*
MT5C6408	F	-15	L	/*
MT5C6408	F	-20	L	/*
MT5C6408	F	-25	L	/*
MT5C6408	F	-35	L	/*
MT5C6408	F	-45	L	/*
MT5C6408	F	-55	L	/*
MT5C6408	F	-70	L	/*

*AVAILABLE PROCESSES

IT = Industrial Temperature Range
 XT = Extended Temperature Range
 883C = Full Military Processing

-40°C to +85°C
 -55°C to +125°C
 -55°C to +125°C

** OPTIONS

L = 2V Data Retention/Low Power

MICROSS TO DSCC PART NUMBER CROSS REFERENCE*

Micross Package Designator C

Micross Part #	SMD Part #
MT5C6808C-12/883C	5962-3829447MZX
MT5C6808C-12L/883C	5962-3829446MZX
MT5C6808C-20/883C	5962-3829458MZA
MT5C6808C-20L/883C	5962-3829457MZA
MT5C6808C-25/883C	5962-3829456MZA
MT5C6808C-25L/883C	5962-3829455MZA
MT5C6808C-35/883C	5962-3829454MZA
MT5C6808C-35L/883C	5962-3829453MZA
MT5C6808C-45/883C	5962-3829452MZA
MT5C6808C-45L/883C	5962-3829451MZA
MT5C6808C-55/883C	5962-3829450MZA
MT5C6808C-55L/883C	5962-3829449MZA
MT5C6808C-70/883C	5962-3829448MZA

Micross Package Designator EC

Micross Part #	SMD Part #
MT5C6808EC-12/883C	5962-3829447MUX
MT5C6808EC-12L/883C	5962-3829446MUX
MT5C6808EC-20/883C	5962-3829458MUA
MT5C6808EC-20L/883C	5962-3829457MUA
MT5C6808EC-25/883C	5962-3829456MUA
MT5C6808EC-25L/883C	5962-3829455MUA
MT5C6808EC-35/883C	5962-3829454MUA
MT5C6808EC-35L/883C	5962-3829453MUA
MT5C6808EC-45/883C	5962-3829452MUA
MT5C6808EC-45L/883C	5962-3829451MUA
MT5C6808EC-55/883C	5962-3829450MUA
MT5C6808EC-55L/883C	5962-3829449MUA
MT5C6808EC-70/883C	5962-3829448MUA

Micross Package Designator F

Micross Part #	SMD Part #
MT5C6808F-12/883C	5962-3829447MMX
MT5C6808F-12L/883C	5962-3829446MMX
MT5C6808F-20/883C	5962-3829458MMA
MT5C6808F-20L/883C	5962-3829457MMA
MT5C6808F-25/883C	5962-3829456MMA
MT5C6808F-25L/883C	5962-3829455MMA
MT5C6808F-35/883C	5962-3829454MMA
MT5C6808F-35L/883C	5962-3829453MMA
MT5C6808F-45/883C	5962-3829452MMA
MT5C6808F-45L/883C	5962-3829451MMA
MT5C6808F-55/883C	5962-3829450MMA
MT5C6808F-55L/883C	5962-3829449MMA
MT5C6808C-70/883C	5962-3829448MZA

*Micross part number is for reference only. Orders received referencing the SMD part number will be processed per the SMD.