

SCHOTTKY BARRIER RECTIFIERS

REVERSE VOLTAGE - **30 to 45** Volts
FORWARD CURRENT - **15** Amperes

FEATURES

- Metal of silicon rectifier, majority carrier conduction
- Guard ring for transient protection
- Low power loss, high efficiency
- High current capability, low VF
- High surge capacity
- Plastic package has UL flammability classification 94V-0
- For use in low voltage, high frequency inverters, free wheeling, and polarity protection applications

MECHANICAL DATA

- Case : D² PAK molded plastic
- Polarity : As marked on the body
- Weight : 0.06 ounces, 1.7 grams

D²PAK

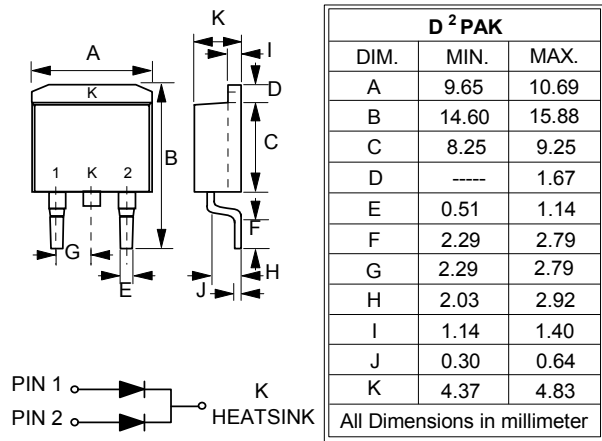

MAXIMUM RATINGS AND ELECTRICAL CHARACTERISTICS

Ratings at 25°C ambient temperature unless otherwise specified.
Single phase, half wave, 60Hz, resistive or inductive load.
For capacitive load, derate current by 20%

CHARACTERISTICS	SYMBOL	MBRB1530CT	MBRB1535CT	MBRB1540CT	MBRB1545CT	UNIT
Maximum Recurrent Peak Reverse Voltage	V _{RRM}	30	35	40	45	V
Maximum RMS Voltage	V _{RMS}	21	24.5	28	31.5	V
Maximum DC Blocking Voltage	V _{DC}	30	35	40	45	V
Maximum Average Forward Rectified Current (See Fig. 1) @T _C =105°C	I _(AV)	15				A
Peak Forward Surge Current 8.3ms single half sine-wave superimposed on rated load (JEDEC METHOD)	I _{FSM}	150				A
Voltage Rate of Change (Rated VR)	dv/dt	10000				V/us
Maximum Forward Voltage at (Note 1)	V _F		-	0.57		V
			0.84			
			0.72			
Maximum DC Reverse Current at Rated DC Blocking Voltage @T _J =25°C @T _J =100°C	I _R		0.1	15		mA
Typical Thermal Resistance	Junction to Case	R _{θJC}	2.0			°C/W
	Junction to Ambient	R _{θJA}	50			°C/W
Typical Junction Capacitance per element (Note 2)	C _J	300				pF
Operating Temperature Range	T _J	-55 to +150				°C
Storage Temperature Range	T _{STG}	-55 to +175				°C

NOTES : 1. 300us Pulse Width, 2% Duty Cycle
2. Measured at 1.0MHz and applied reverse voltage of 4.0V DC.

