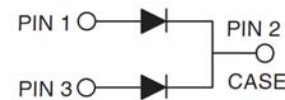

Dual Common Cathode Schottky Rectifier

FEATURES

- UL Recognized File # E-326243
- Low power loss, high efficiency
- Guardring for overvoltage protection
- High surge current capability
- Compliant to RoHS Directive 2011/65/EU and in accordance to WEEE 2002/96/EC
- Halogen-free according to IEC 61249-2-21 definition

TO-247AD(TO-3P)

MECHANICAL DATA

Case : TO-247AD(TO-3P)

Molding compound, UL flammability classification rating 94V-0
 Base P/N with suffix "G" on packing code - halogen-free, RoHS compliant
 Base P/N with prefix "H" on packing code - AEC-Q101 qualified

Terminal : Matte tin plated leads, solderable per JESD22-B102
 Meet JESD 201 class 1A whisker test,
 with prefix "H" on packing code meet JESD 201 class 2 whisker test

Polarity : As marked

Mounting torque : 10 in-lbs maximum

Weight : 6.1 gram (approximately)

MAXIMUM RATINGS AND ELECTRICAL CHARACTERISTICS (T_A=25°C unless otherwise noted)

PARAMETER	SYMBOL	SR 2020 PT	SR 2030 PT	SR 2040 PT	SR 2050 PT	SR 2060 PT	SR 2090 PT	SR 20100 PT	SR 20150 PT	UNIT	
Maximum repetitive peak reverse voltage	V _{RRM}	20	30	40	50	60	90	100	150	V	
Maximum RMS voltage	V _{RMS}	14	21	28	35	42	63	70	105	V	
Maximum DC blocking voltage	V _{DC}	20	30	40	50	60	90	100	150	V	
Maximum average forward rectified current	I _{F(AV)}	20								A	
Peak forward surge current, 8.3 ms single half sine-wave superimposed on rated load	I _{FSM}	200								A	
Maximum instantaneous forward voltage (Note 1) IF= 10 A	V _F	0.55			0.70		0.92		1.02	V	
Maximum reverse current @ rated VR T _J =25 °C T _J =100 °C T _J =125 °C	I _R	0.5					0.1				mA
		15			10		-				
		-					5				
Typical thermal resistance	R _{θJC}	1.5								°C/W	
Operating junction temperature range	T _J	- 55 to + 125				- 55 to + 150					°C
Storage temperature range	T _{STG}	- 55 to + 150									°C

Note 1 : Pulse test with PW=300u sec, 1% duty cycle

ORDERING INFORMATION					
PART NO.	AEC-Q101 QUALIFIED	PACKING CODE	GREEN COMPOUND CODE	PACKAGE	PACKING
SR20xxPT (Note 1)	Prefix "H"	C0	Suffix "G"	TO-3P	30 / Tube

Note 1: "xx" defines voltage from 20V (SR2020PT) to 150V (SR20150PT)

EXAMPLE					
PREFERRED P/N	PART NO.	AEC-Q101 QUALIFIED	PACKING CODE	GREEN COMPOUND CODE	DESCRIPTION
SR2060PT C0	SR2060PT		C0		
SR2060PT C0G	SR2060PT		C0	G	Green compound
SR2060PTH0	SR2060PT	H	C0		AEC-Q101 qualified

RATINGS AND CHARACTERISTICS CURVES

(TA=25°C unless otherwise noted)

FIG. 1- FORWARD CURRENT DERATING CURVE

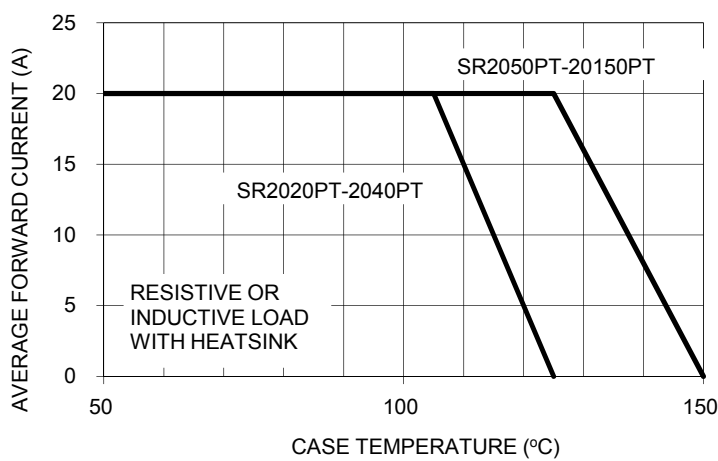

FIG. 2- MAXIMUM NON-REPETITIVE FORWARD SURGE CURRENT PER LEG

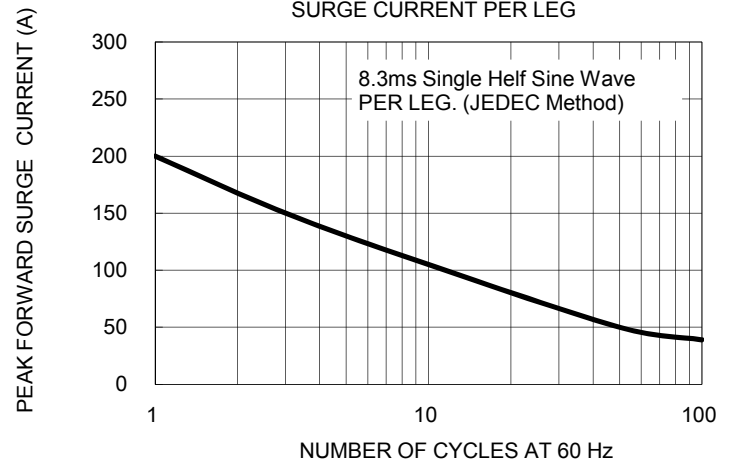

FIG. 3- TYPICAL FORWARD CHARACTERISTICS PER LEG

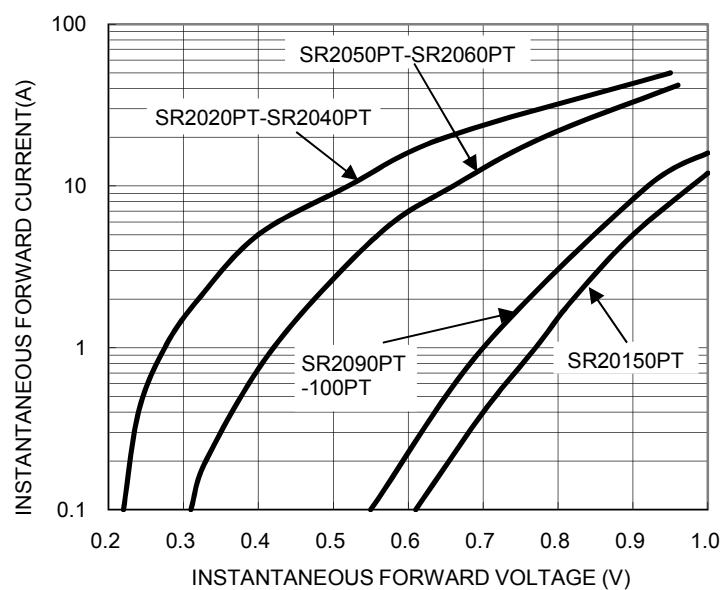

FIG. 4- TYPICAL REVERSE CHARACTERISTICS PER LEG

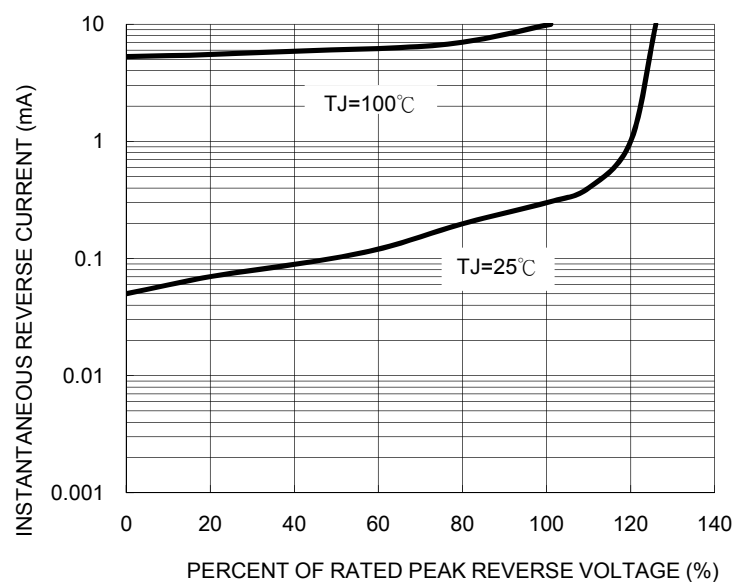

FIG. 5- TYPICAL JUNCTION CAPACITANCE PER LEG

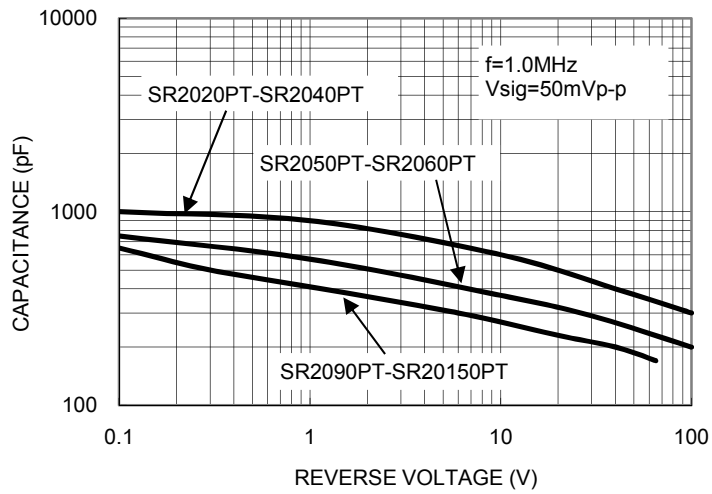
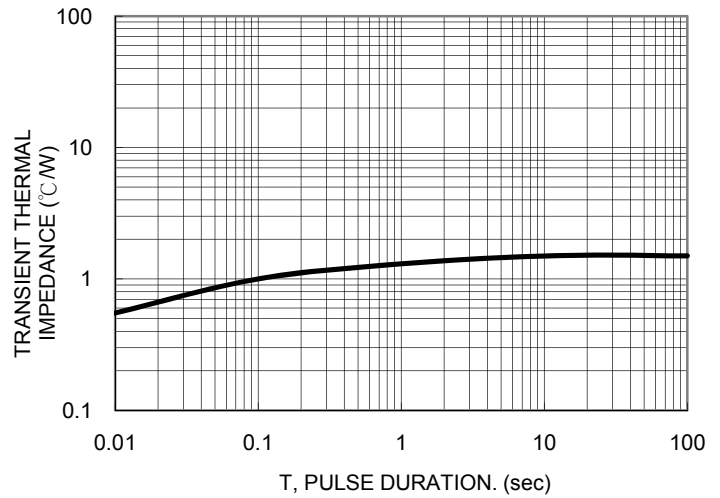
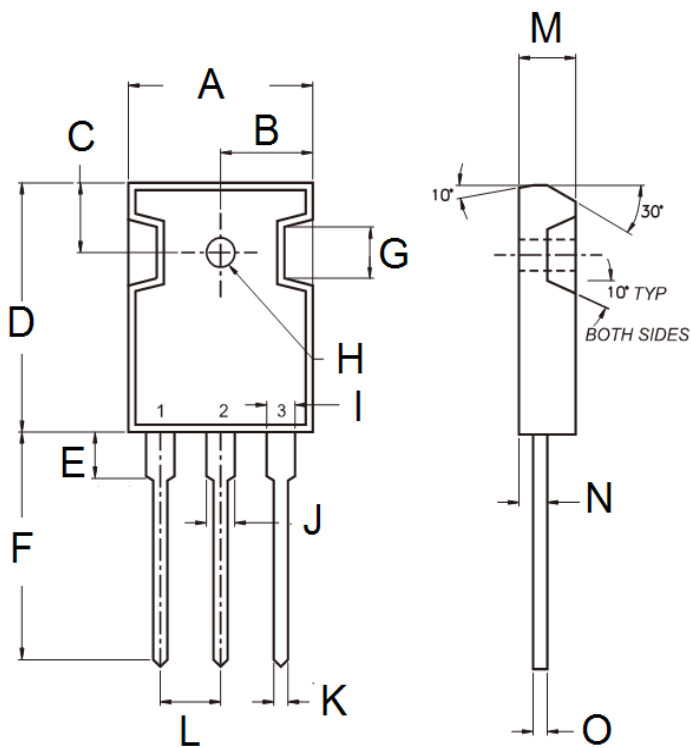

FIG. 6- TYPICAL TRANSIENT THERMAL IMPEDANCE PER LEG



PACKAGE OUTLINE DIMENSIONS



DIM.	Unit(mm)		Unit(inch)	
	Min	Max	Min	Max
A	15.90	16.40	0.626	0.646
B	7.90	8.20	0.311	0.323
C	5.70	6.20	0.224	0.244
D	20.80	21.30	0.819	0.839
E	3.50	4.10	0.138	0.161
F	19.70	20.20	0.776	0.795
G	-	4.30	-	0.169
H	2.90	3.40	0.114	0.134
I	1.93	2.18	0.076	0.086
J	2.97	3.22	0.117	0.127
K	1.12	1.22	0.044	0.048
L	5.20	5.70	0.205	0.224
M	4.90	5.16	0.193	0.203
N	2.70	3.00	0.106	0.118
O	0.51	0.76	0.020	0.030

MARKING DIAGRAM



- P/N = Marking Code
- G = Green Compound
- YWW = Date Code
- F = Factory Code