



2SB808/2SD1012

Low-Voltage Large-Current Amplifier Applications

Package Dimensions

unit:mm

2033A

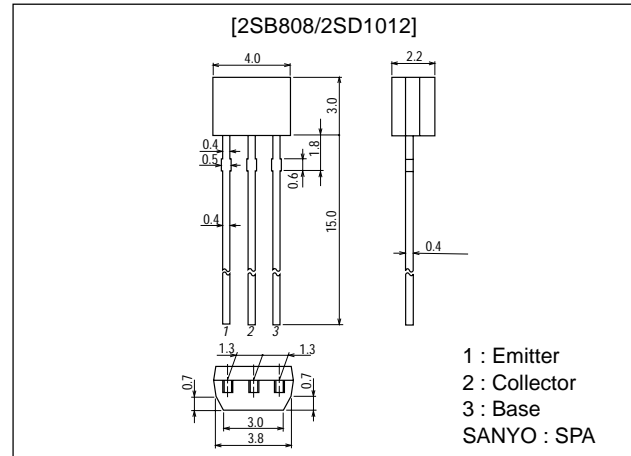

() : 2SB808

Specifications

Absolute Maximum Ratings at $T_a = 25^\circ\text{C}$

Parameter	Symbol	Conditions	Ratings	Unit
Collector-to-Base Voltage	V_{CB0}		(-)20	V
Collector-to-Emitter Voltage	V_{CEO}		(-)15	V
Emitter-to-Base Voltage	V_{EBO}		(-)5	V
Collector Current	I_C		(-)0.7	A
Collector Current (Pulse)	I_{CP}		(-)1.5	A
Collector Dissipation	P_C		250	mW
Junction Temperature	T_J		125	$^\circ\text{C}$
Storage Temperature	T_{stg}		-55 to +125	$^\circ\text{C}$

Electrical Characteristics at $T_a = 25^\circ\text{C}$

Parameter	Symbol	Conditions	Ratings			Unit
			min	typ	max	
Collector Cutoff Current	I_{CBO}	$V_{CB}=(-)15\text{V}, I_E=0$			(-)1.0	μA
Emitter Cutoff Current	I_{EBO}	$V_{EB}=(-)4\text{V}, I_C=0$			(-)1.0	μA
DC Current Gain	h_{FE1}	$V_{CE}=(-)2\text{V}, I_C=(-)50\text{mA}$	160*		960*	
	h_{FE2}	$V_{CE}=(-)2\text{V}, I_C=(-)500\text{mA Pulse}$	80			
Gain-Bandwidth Product	f_T	$V_{CE}=(-)10\text{V}, I_C=(-)50\text{mA}$		250		MHz
Common Base Output Capacitance	C_{ob}	$V_{CB}=(-)10\text{V}, f=1\text{MHz}$		(13)		pF
				8		pF

Continued on next page.

■ Any and all SANYO products described or contained herein do not have specifications that can handle applications that require extremely high levels of reliability, such as life-support systems, aircraft's control systems, or other applications whose failure can be reasonably expected to result in serious physical and/or material damage. Consult with your SANYO representative nearest you before using any SANYO products described or contained herein in such applications.

■ SANYO assumes no responsibility for equipment failures that result from using products at values that exceed, even momentarily, rated values (such as maximum ratings, operating condition ranges, or other parameters) listed in products specifications of any and all SANYO products described or contained herein.

SANYO Electric Co., Ltd. Semiconductor Company

TOKYO OFFICE Tokyo Bldg., 1-10, 1 Chome, Ueno, Taito-ku, TOKYO, 110-8534 JAPAN

91003TN (KT)/91098HA (KT)/1115MY/1283KI, TS No.676-1/5

2SB808/2SD1012

Continued from preceding page.

Parameter	Symbol	Conditions	Ratings			Unit
			min	typ	max	
Collector-to-Emitter Saturation Voltage	$V_{CE(sat)1}$	$I_C=(-)5mA, I_B=(-)0.5mA$		(-15)	(-35)	mV
	$V_{CE(sat)2}$	$I_C=(-)100mA, I_B=(-)10mA$		10	25	mV
Base-to-Emitter Saturation Voltage	$V_{BE(sat)}$	$I_C=(-)100mA, I_B=(-)10mA$		(-60)	(-120)	mV
Collector-to-Base Breakdown Voltage	$V_{(BR)CBO}$	$I_C=(-)10\mu A, I_E=0$	(-)	30	80	mV
Collector-to-Emitter Breakdown Voltage	$V_{(BR)CEO}$	$I_C=(-)1mA, R_{BE}=\infty$	(-)			V
Emitter-to-Base Breakdown Voltage	$V_{(BR)EBO}$	$I_E=(-)10\mu A, I_C=0$	(-)			V

* : The 2SB808/2SD1012 are classified by 50mA h_{FE} as follows :

2SB808	Rank	F	G	
	h_{FE}	160 to 320	280 to 560	
2SD1012	Rank	F	G	H
	h_{FE}	160 to 320	280 to 560	480 to 960

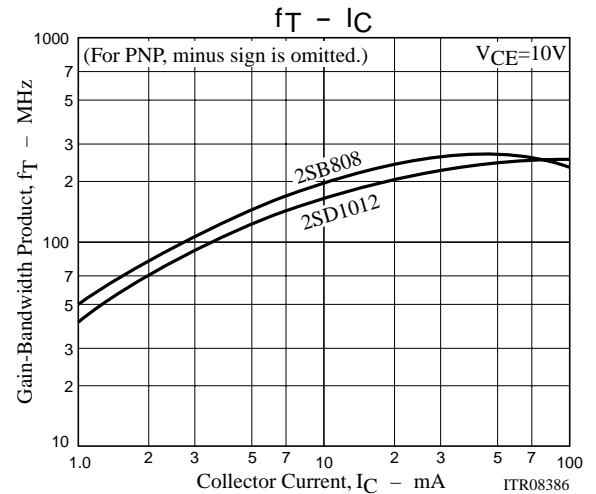
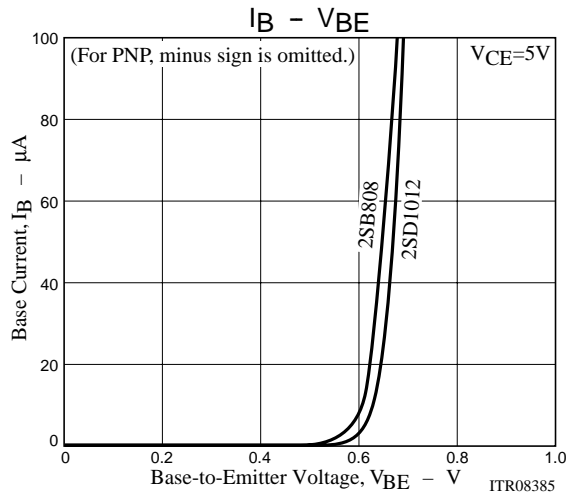
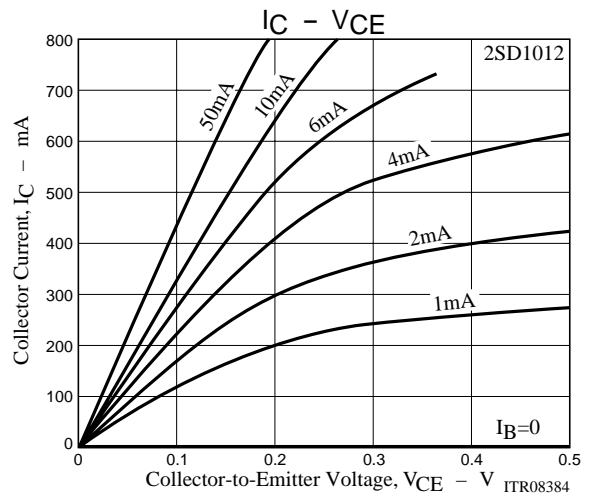
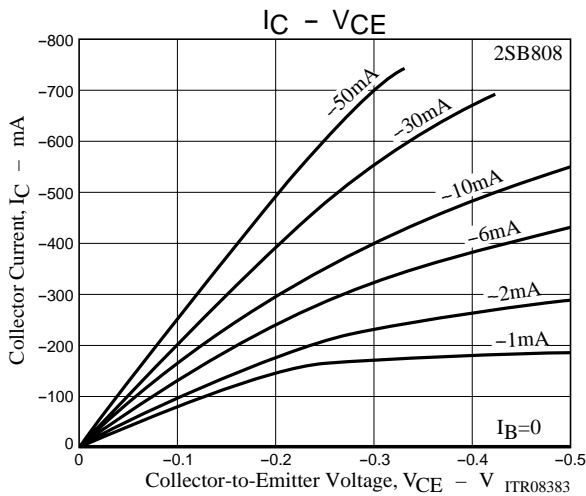

2SB808/2SD1012

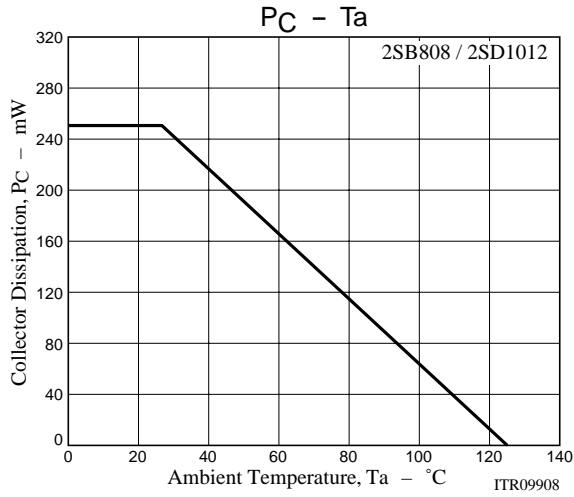
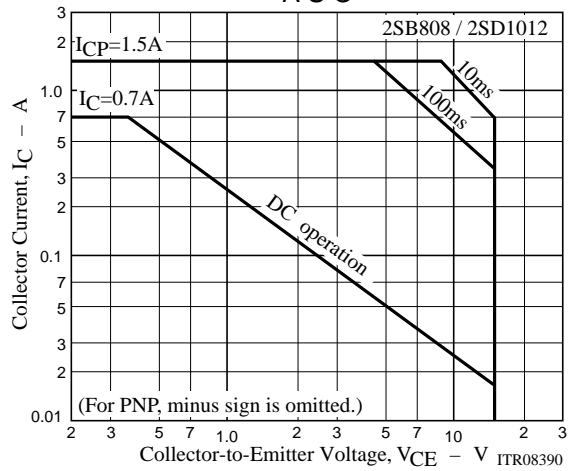
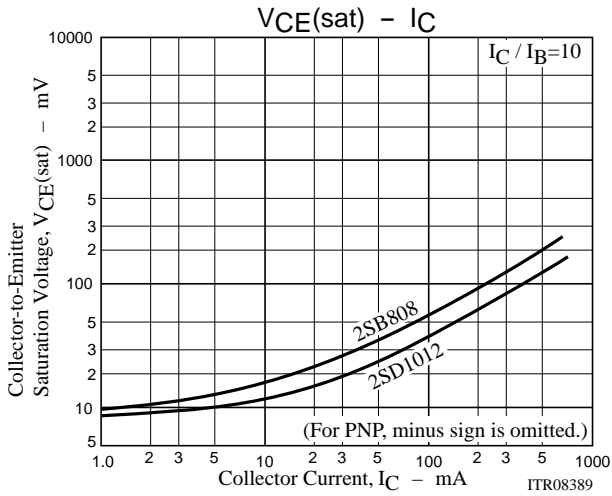
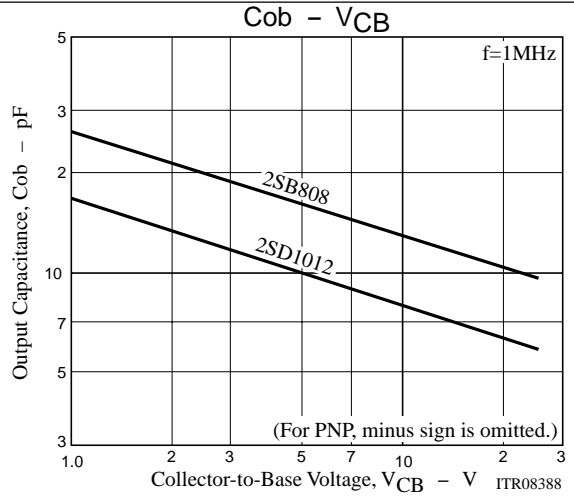
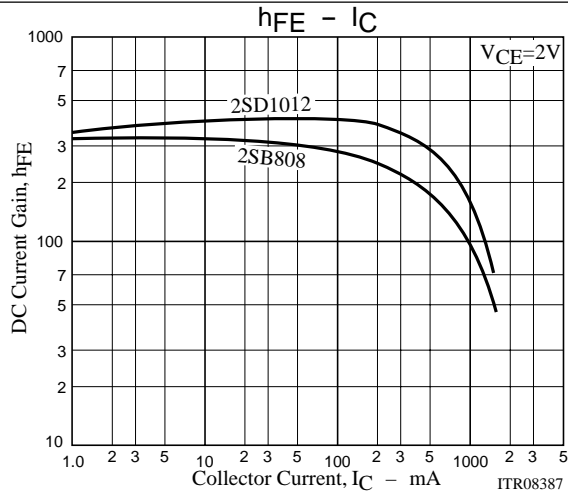

2SB808/2SD1012

Sample Application Circuit : Low-voltage 3V (P_O 120mW) ITL-OTL power amplifier.

Circuit configuration

For obtaining an output of more than 100mW, the middle-point voltage at the output stage and the collector voltage of the driver transistor must be $V_{CC}/2$. Therefore, the output stage is of quasi complementary configuration composed of npn/npn transistors. The phase is reversed by the 2SA608 and the middle-point voltage are the output stage and the collector voltage of the driver transistor are more to be $V_{CC}/2$ so that the output can be maximized.

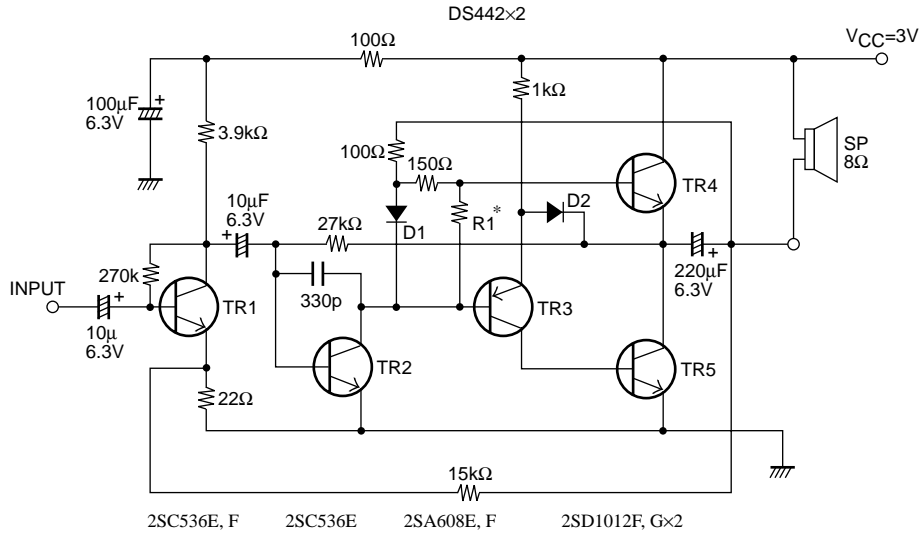

R1 : Used control idele current
 For R1=820Ω. use rank F for [TR4, 5(2SD1012)]
 For R1=680Ω. use rank G for [TR4, 5(2SD1012)]

ITR09909

Main Specifications

Characteristic	Conditions	f=400Hz	f=1kHz	Unit
Current dissipation	Quiescent, total current dissipation	11.0 to 15.5	11.0 to 15.5	mA
Output power	THD=10%	120 to 125	127 to 130	mW
Voltage gain	P _O =10mW	43.3 to 45.5	43.5 to 45.7	dB
Total harmonic distortion	P _O =50mW	1.4 to 2.6	1.3 to 2.5	%
Input resistance	P _O =10mW	10.4 to 20.5	11.0 to 21.0	kΩ

Note : for above-mentioned h_{FE} rank.

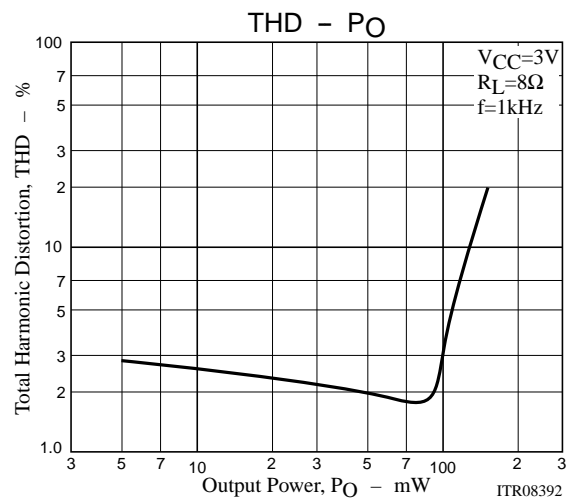
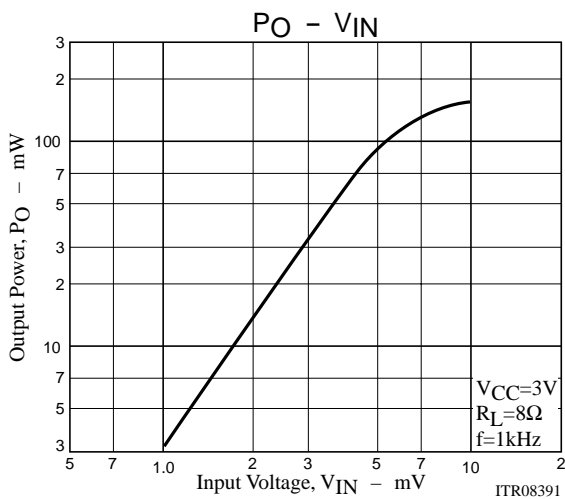

2SB808/2SD1012

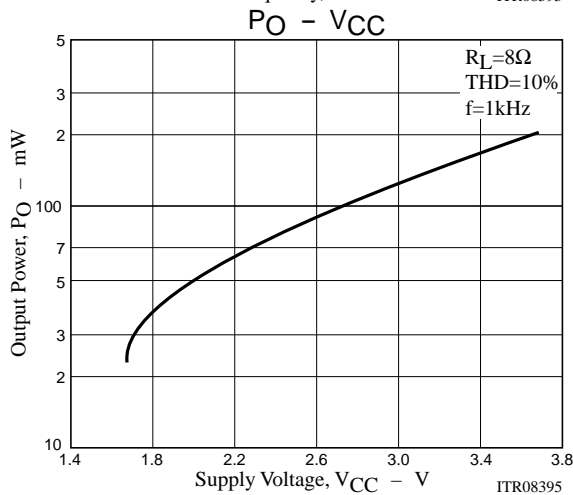
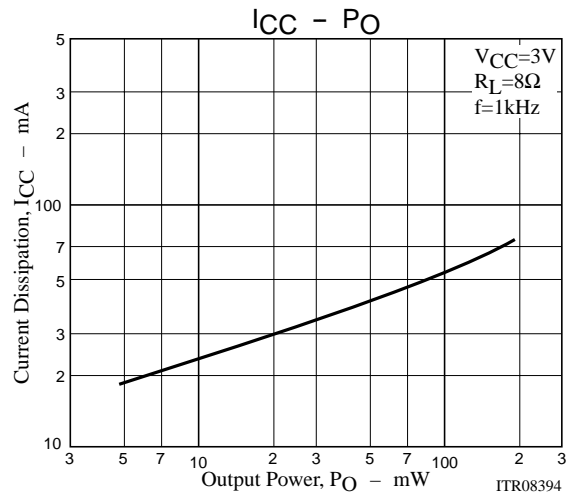
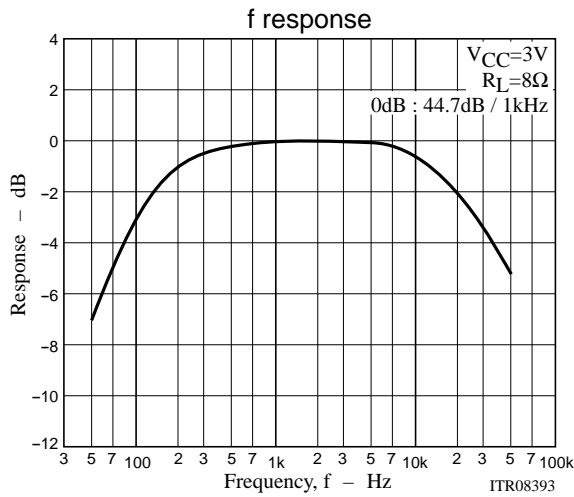

- Specifications of any and all SANYO products described or contained herein stipulate the performance, characteristics, and functions of the described products in the independent state, and are not guarantees of the performance, characteristics, and functions of the described products as mounted in the customer's products or equipment. To verify symptoms and states that cannot be evaluated in an independent device, the customer should always evaluate and test devices mounted in the customer's products or equipment.
- SANYO Electric Co., Ltd. strives to supply high-quality high-reliability products. However, any and all semiconductor products fail with some probability. It is possible that these probabilistic failures could give rise to accidents or events that could endanger human lives, that could give rise to smoke or fire, or that could cause damage to other property. When designing equipment, adopt safety measures so that these kinds of accidents or events cannot occur. Such measures include but are not limited to protective circuits and error prevention circuits for safe design, redundant design, and structural design.
- In the event that any or all SANYO products (including technical data, services) described or contained herein are controlled under any of applicable local export control laws and regulations, such products must not be exported without obtaining the export license from the authorities concerned in accordance with the above law.
- No part of this publication may be reproduced or transmitted in any form or by any means, electronic or mechanical, including photocopying and recording, or any information storage or retrieval system, or otherwise, without the prior written permission of SANYO Electric Co., Ltd.
- Any and all information described or contained herein are subject to change without notice due to product/technology improvement, etc. When designing equipment, refer to the "Delivery Specification" for the SANYO product that you intend to use.
- Information (including circuit diagrams and circuit parameters) herein is for example only; it is not guaranteed for volume production. SANYO believes information herein is accurate and reliable, but no guarantees are made or implied regarding its use or any infringements of intellectual property rights or other rights of third parties.

This catalog provides information as of September, 2003. Specifications and information herein are subject to change without notice.