



DM74S03 Quad 2-Input NAND Gates with Open-Collector Outputs

General Description

This device contains four independent gates each of which performs the logic NAND function. The open-collector outputs require external pull-up resistors for proper logical operation.

Pull-Up Resistor Equations

$$R_{MAX} = \frac{V_{CC} (Min) - V_{OH}}{N_1 (I_{OH}) + N_2 (I_{IH})}$$

$$R_{MIN} = \frac{V_{CC} (Max) - V_{OL}}{I_{OL} - N_3 (I_{IL})}$$

Where: $N_1 (I_{OH})$ = total maximum output high current for all outputs tied to pull-up resistor

$N_2 (I_{IH})$ = total maximum input high current for all inputs tied to pull-up resistor

$N_3 (I_{IL})$ = total maximum input low current for all inputs tied to pull-up resistor

Connection Diagram

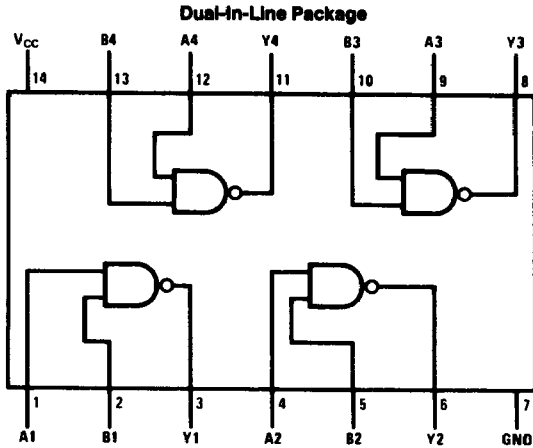

TL/F/6491-1

Order Number DM74S03N
See NS Package Number N14A

Function Table

$$Y = \overline{AB}$$

Inputs		Output
A	B	Y
L	L	H
L	H	H
H	L	H
H	H	L

H = High Logic Level

L = Low Logic Level

Absolute Maximum Ratings (Note)

Supply Voltage	7V
Input Voltage	5.5V
Output Voltage	7V
Operating Free Air Temperature Range DM74S	0°C to +70°C
Storage Temperature Range	-65°C to +150°C

Note: The "Absolute Maximum Ratings" are those values beyond which the safety of the device cannot be guaranteed. The device should not be operated at these limits. The parametric values defined in the "Electrical Characteristics" table are not guaranteed at the absolute maximum ratings. The "Recommended Operating Conditions" table will define the conditions for actual device operation.

Recommended Operating Conditions

Symbol	Parameter	DM74S03			Units
		Min	Nom	Max	
V _{CC}	Supply Voltage	4.75	5	5.25	V
V _{IH}	High Level Input Voltage	2			V
V _{IL}	Low Level Input Voltage			0.8	V
V _{OH}	High Level Output Voltage			5.5	V
I _{OL}	Low Level Output Current			20	mA
T _A	Free Air Operating Temperature	0		70	°C

Electrical Characteristics over recommended operating free air temperature (unless otherwise noted)

Symbol	Parameter	Conditions	Min	Typ (Note 1)	Max	Units
V _I	Input Clamp Voltage	V _{CC} = Min, I _I = -18 mA			-1.2	V
I _{CEX}	High Level Output Current	V _{CC} = Min, V _O = 5.5V V _{IL} = Max			250	μA
V _{OL}	Low Level Output Voltage	V _{CC} = Min, I _{OL} = Max V _{IH} = Min			0.5	V
I _I	Input Current @ Max Input Voltage	V _{CC} = Max, V _I = 5.5V			1	mA
I _{IH}	High Level Input Current	V _{CC} = Max, V _I = 2.7V			50	μA
I _{IL}	Low Level Input Current	V _{CC} = Max, V _I = 0.5V			-2	mA
I _{CCH}	Supply Current with Outputs High	V _{CC} = Max		6.0	13.2	mA
I _{CCL}	Supply Current with Outputs Low	V _{CC} = Max		20	36	mA

Switching Characteristics at V_{CC} = 5V and T_A = 25°C (See Section 1 for Test Waveforms and Output Load)

Symbol	Parameter	R _L = 280Ω				Units
		C _L = 15 pF		C _L = 50 pF		
		Min	Max	Min	Max	
t _{PLH}	Propagation Delay Time Low to High Level Output	2	7.5	3	11	ns
t _{PHL}	Propagation Delay Time High to Low Level Output	2	7	3	11	ns

Note 1: All typicals are at V_{CC} = 5V, T_A = 25°C.