



Micro Commercial Components
20736 Marilla Street Chatsworth
CA 91311
Phone: (818) 701-4933
Fax: (818) 701-4939

2N2219A

Features

- Meets MIL 19500 /251
- Collector - Base Voltage 75 V
- Collector - Current 800 mA
- Medium Current, Bipolar Transistor
- Available in TO-5

**SWITCHING
TRANSISTOR
JAN, JANTX, JANTXV**

**SMALL SIGNAL
BIPOLAR
NPN SILICON**

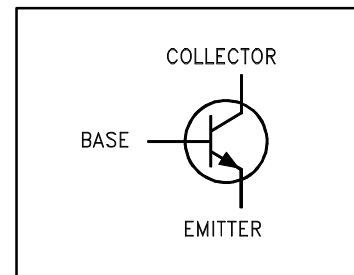
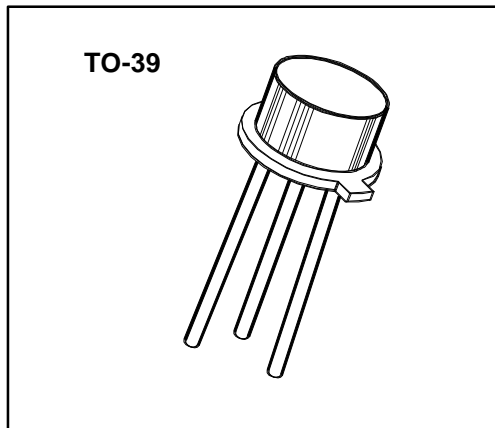

Collector - Emitter Voltage	V_{CEO}	50	Vdc
Collector - Base Voltage	V_{CBO}	75	Vdc
Emitter - Base Voltage	V_{EBO}	6	Vdc
Collector Current - Continuous	I_C	800	mAdc
Total Device Dissipation @ $T_A = 25\text{ }^\circ\text{C}$	P_D	0.8	WATTS
Derate above $25\text{ }^\circ\text{C}$		4.6	mW/ $^\circ\text{C}$
Total Device Dissipation @ $T_C = 25\text{ }^\circ\text{C}$	P_D	1.0	WATTS
Derate above $25\text{ }^\circ\text{C}$		17.0	mW/ $^\circ\text{C}$
Operating Junction&Storage Temperature Range	T_J, T_{stg}	-55 to +200	$^\circ\text{C}$

Thermal Characteristics

CHARACTERISTIC	SYMBOL	MAX	UNIT
Thermal Resistance, Junction to Ambient	$R\theta_{JA}$	217	$^\circ\text{C}/\text{W}$
Thermal Resistance, Junction to Case	$R\theta_{JC}$	59	$^\circ\text{C}/\text{W}$

2N2219A



Electrical Characteristics ($T_A = 25^\circ\text{C}$ unless otherwise noted)

OFF CHARACTERISTIC	SYMBOL	MIN	MAX	UNIT
Collector - Emitter Breakdown Voltage (1) ($I_C = 10 \text{ mA dc}, I_B = 0$)	$V(\text{BR})_{\text{CEO}}$	50		Vdc
Collector - Base Breakdown Voltage ($I_C = 10 \mu\text{A dc}, I_E = 0$)	$V(\text{BR})_{\text{CBO}}$	75		Vdc
Emitter - Base Breakdown Voltage ($I_E = 10 \mu\text{A dc}, I_C = 0$)	$V(\text{BR})_{\text{EBO}}$	6		Vdc
Collector - Emitter Cutoff Current ($V_{\text{CE}} = 50 \text{ Vdc}$)	I_{CES}		10	nAdc
Collector - Base Cutoff Current ($V_{\text{CB}} = 60 \text{ Vdc}, I_E = 0$)	I_{CBO}		10	nAdc
($V_{\text{CB}} = 60 \text{ Vdc}, I_E = 0, T_A = 150^\circ\text{C}$)			10	μAdc
Emitter - Base Cutoff Current ($V_{\text{EB}} = 4 \text{ Vdc}$)	I_{EBO}		10	nAdc
($V_{\text{EB}} = 6 \text{ Vdc}$)			10	μAdc

ON CHARACTERISTIC	SYMBOL	MIN	MAX	UNIT
DC Current Gain	h_{FE}			
($I_C = 0.1 \text{ mA dc}, V_{\text{CE}} = 10 \text{ Vdc}$) (1)		50		
($I_C = 1 \text{ mA dc}, V_{\text{CE}} = 10 \text{ Vdc}$) (1)		75	325	
($I_C = 10 \text{ mA dc}, V_{\text{CE}} = 10 \text{ Vdc}$) (1)		100		
($I_C = 150 \text{ mA dc}, V_{\text{CE}} = 10 \text{ Vdc}$) (1)		100	300	
($I_C = 500 \text{ mA dc}, V_{\text{CE}} = 10 \text{ Vdc}$) (1)		30		
($I_C = 10 \text{ mA dc}, V_{\text{CE}} = 10 \text{ Vdc}, T_J = -55^\circ\text{C}$) (1)		35		
Collector - Emitter Saturation Voltage	$V_{\text{CE(sat)}}$			
($I_C = 150 \text{ mA dc}, I_B = 15 \text{ mA dc}$) (1)			0.3	Vdc
($I_C = 500 \text{ mA dc}, I_B = 50 \text{ mA dc}$) (1)			1.0	Vdc
Base - Emitter Saturation Voltage	$V_{\text{BE(sat)}}$			
($I_C = 150 \text{ mA dc}, I_B = 15 \text{ mA dc}$) (1)		0.6	1.2	Vdc
($I_C = 500 \text{ mA dc}, I_B = 50 \text{ mA dc}$) (1)			2.0	Vdc

1. Pulse Test: Pulse Width $\leq 300 \mu\text{s}$, Duty Cycle $\leq 2\%$

2N2219A



Electrical Characteristics ($T_A = 25^\circ\text{C}$ unless otherwise noted)

SMALL - SIGNAL CHARACTERISTICS	SYMBOL	MIN	MAX	UNIT
Output Capacitance	C_{obo}			
($V_{CB} = 10 \text{ Vdc}$, $I_E = 0$, $100\text{kHz} \leq f \leq 1 \text{ MHz}$)			8.0	pF
Input Capacitance	C_{ibo}			
($V_{EB} = 0.5 \text{ Vdc}$, $I_C = 0$, $100\text{kHz} \leq f \leq 1 \text{ MHz}$)			25	pF

SWITCHING CHARACTERISTICS	SYMBOL	MIN	MAX	UNIT
Turn - On Time	t_{on}			
($V_{CC} = 30 \text{ Vdc}$, $I_C = 150 \text{ mAdc}$, $I_{B1} = 15 \text{ mAdc}$) (See FIGURE 1)			35	ns
Turn - Off Time	t_{off}			
($V_{CC} = 30 \text{ Vdc}$, $I_C = 150 \text{ mAdc}$, $I_{B1} = - I_{B2} = 15 \text{ mAdc}$) (See FIGURE 2)			300	ns

Small - Signal AC Characteristics ($T_A = 25^\circ\text{C}$)

LOW FREQUENCY	SYMBOL	MIN	MAX	UNIT
Common - Emitter Forward Current Transfer Ratio	h_{fe}			
($I_C = 1 \text{ mA}$, $V_{CE} = 10 \text{ V}$, $f = 1 \text{ kHz}$)		75		
HIGH FREQUENCY				
Common - Emitter Forward Current Transfer Ratio	$ h_{fe} $			
($I_C = 20 \text{ mA}$, $V_{CE} = 20 \text{ V}$, $f = 100 \text{ MHz}$)		2.5	12	

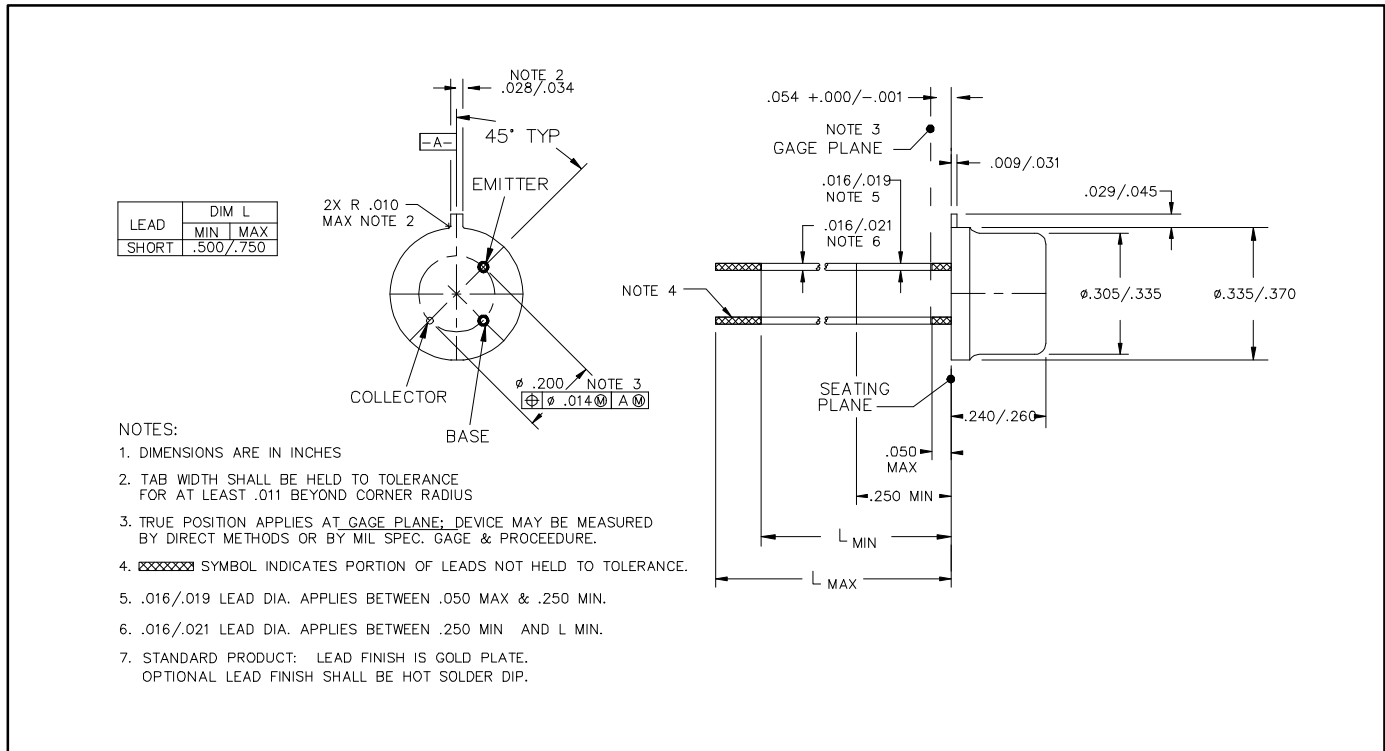

TO-39 CASE OUTLINE

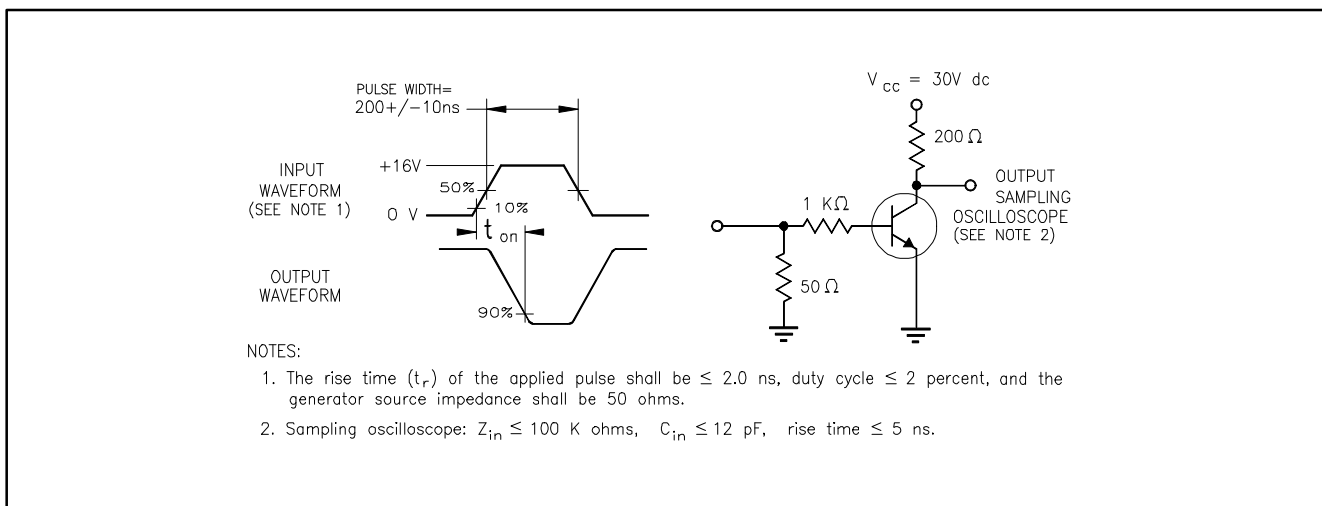

FIGURE 1 Saturated Turn-on Time Test Circuit

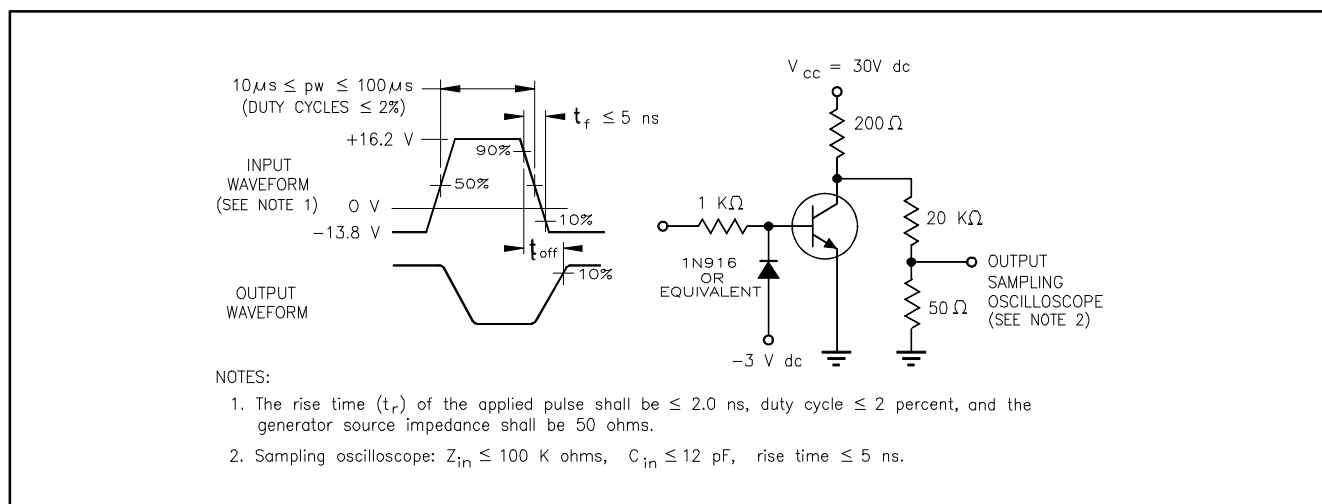

FIGURE 2 Saturated Turn-off Time Test Circuit

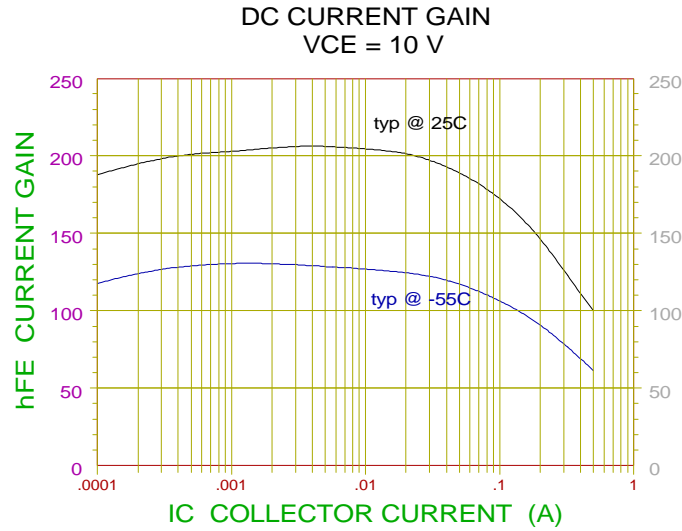

FIGURE 3

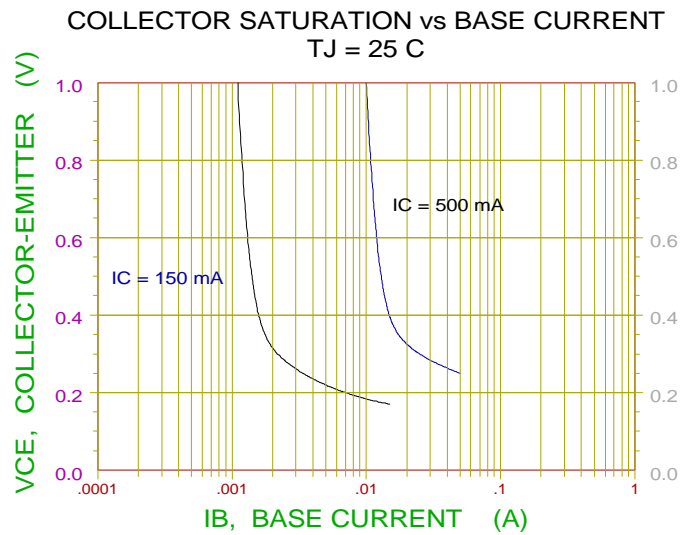

FIGURE 4

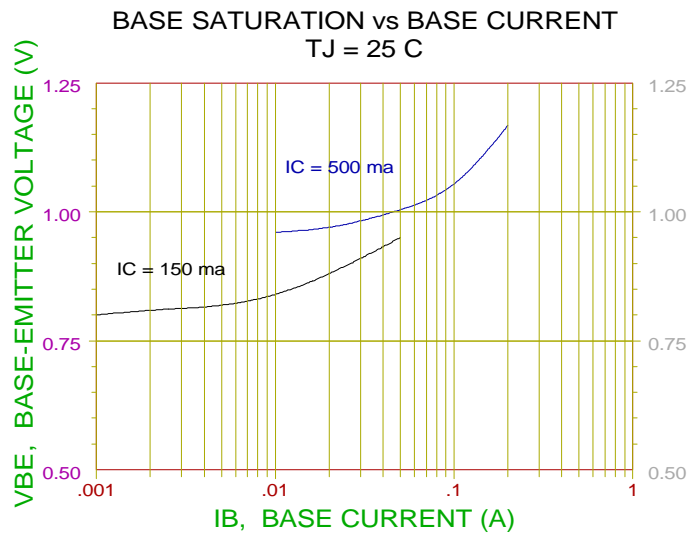

FIGURE 5

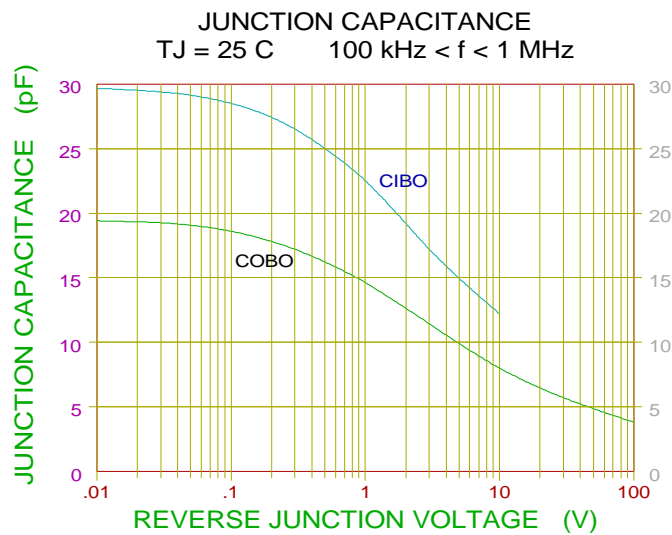

FIGURE 6

SWITCHING TURN - ON TIME
T_J = 25 C IC/IB = 10

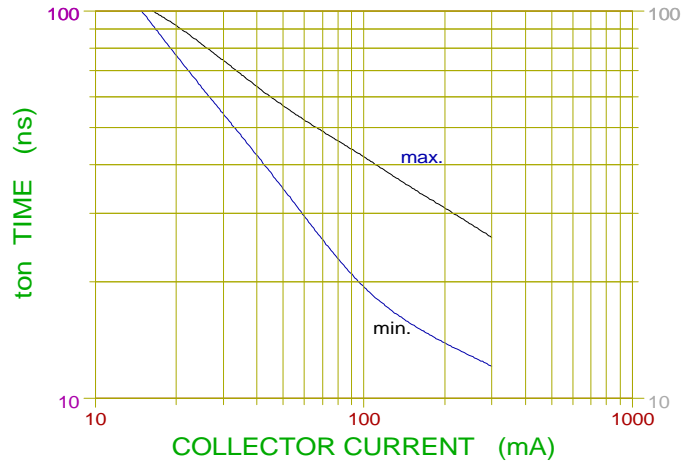

FIGURE 7

SWITCHING TURN - OFF TIME
T_J = 25 C IC/IB = 10

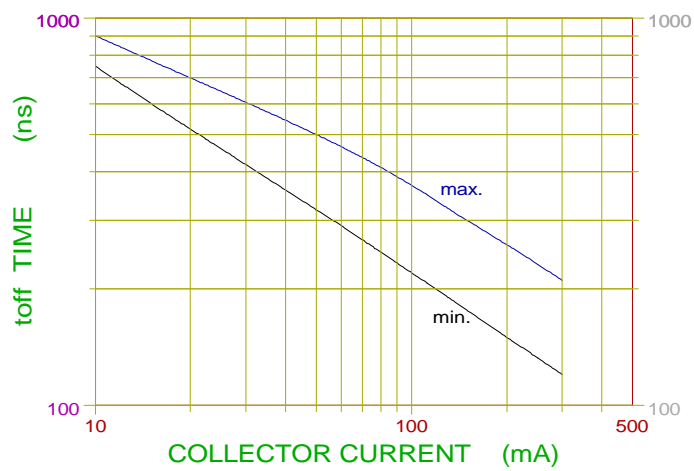

FIGURE 8

2N2219A

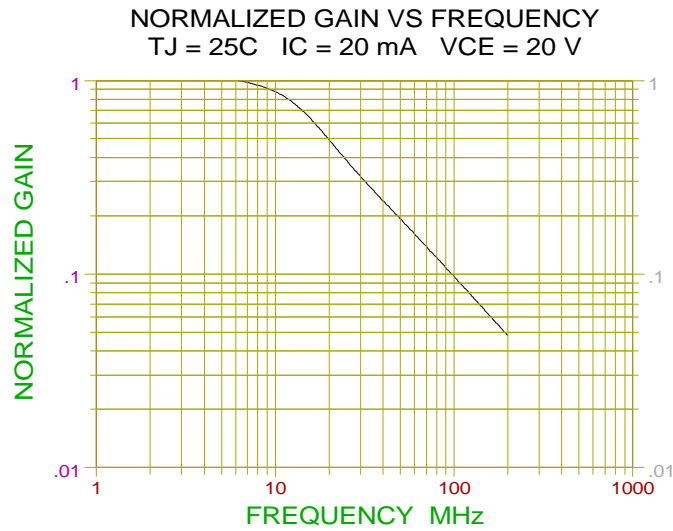

FIGURE 9