

SCHEMATIC

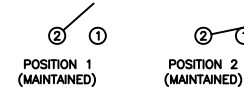

SPECIFICATIONS

FUNCTION:
1P1T OFF-ON

RATINGS:
ANSI/UL 1054 and CAN/CSA C22.2 No. 55 (E194579):
16A 125VAC [UR, cUR]
10A 250VAC [UR, cUR]
1/3HP 125/250VAC [UR, cUR]

EN 61058-1:2002:
10(4)A 250V~ μ 1E4 T125/55 [ENEC14, SEMKO]
10(2)A 250V~ μ 5E4 T85/55 [ENEC14, SEMKO]

CONTACT RESISTANCE:
Initial: 35mΩ Max. at 50VAC

INSULATION RESISTANCE:
100MΩ Min. at 500VDC

DIELECTRIC STRENGTH:
1,500VAC For 1 Minute

ELECTRICAL LIFE:
6,000 Cycles [UR, cUR]
10,000 Cycles [ENEC14, SEMKO: 10(4)A 250V~]
50,000 Cycles [ENEC14, SEMKO: 10(2)A 250V~]

TEMPERATURE:
Operating: -20°C to 105°C [UR, cUR]
Operating: -20°C to 125°C [ENEC14, SEMKO: 10(4)A 250V~]
Operating: -20°C to 85°C [ENEC14, SEMKO: 10(2)A 250V~]

APPROVALS:

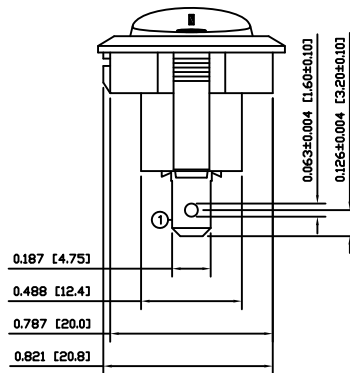
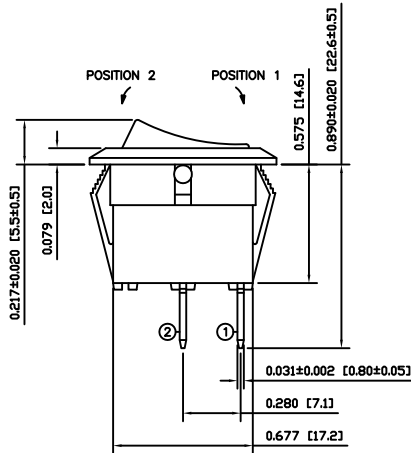
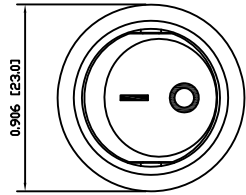

COLORS AND MARKINGS

BODY:
White

ACTUATOR:
White

MARKINGS:
I/O Vertical (1)

MARKING COLOR:
Black

MATERIALS

BODY:
Polyamide 6/6 (PA66), UL94 V-2

ACTUATOR:
Polyamide 6/6 (PA66), UL94 V-2

SPRING:
Steel

SPRING COVER:
Steel

CONTACTS:
Silver Alloy Plated Copper

TERMINALS:
Silver Plated Copper

SUGGESTED PANEL CUTOUT

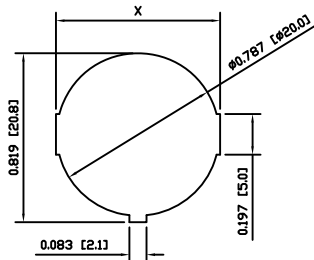

PANEL THICKNESS	X
0.030~0.049 [0.75~1.25]	0.795 [20.2]
0.049~0.079 [1.25~2.00]	0.803 [20.4]
0.079~0.118 [2.00~3.00]	0.811 [20.6]

ACTUATOR	A	09/08/10	CAB
BODY	B	10/03/31	CAB
COLORS	A	10/01/13	CAB
MATERIALS	A	09/08/10	CAB
SPECIFICATIONS	A	09/08/10	CAB
REFERENCE	REV.	DATE	BY

THE INFORMATION CONTAINED IN THIS DOCUMENT IS PROPRIETARY TO E-SWITCH-LAMB INDUSTRIES AND IS NOT TO BE COPIED OR TRANSFERRED

A	INITIAL RELEASE	19483	10/11/30	CAB
REV.	DESCRIPTION	PCR	DATE	DRAWN BY

DIMENSIONS	TITLE
INCHES [MILLIMETERS]	RR111C2211
GENERAL TOLERANCES	
±0.008 [±0.2] / ±1'	
SCALE	PROJECTION
DRAWING NOT TO SCALE	3RD ANGLE

RR111C2211

ITEM NUMBER	DATE	REVISION
38-RR111C2211	NOVEMBER 30, 2010	A