

DIMENSIONS	D	17.91	22.99	25.53	30.61	38.23	43.31	48.39	56.01	68.71	81.41	86.49
	C	-	-	-	-	17.78	17.78	17.78	25.4	17.78	25.4	25.4
B	10.16	15.24	17.78	22.86	30.48	35.56	40.64	48.26	60.96	73.66	78.74	
+0.25 A-0	19.71	24.79	27.33	32.41	40.03	45.11	50.19	57.81	70.51	83.21	88.29	
NO.OF POSITIONS	10	14	16	20	26	30	34	40	50	60	64	

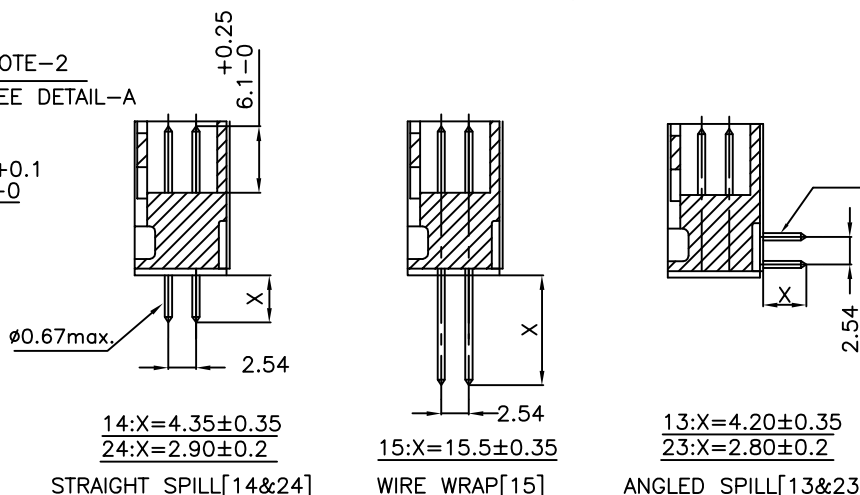

ORDERING INFORMATION

8613 0 1 0

SERIES: 8613

NO.OF CONTACTS :- 10,14,16,20,26,30,34, 40,50,60,64

BOX HEADER WITHOUT LEVER

TYPE OF TERMINATION:
 13 - LONG ANGLED SPILL
 14 - LONG STRAIGHT SPILL
 23 - SHORT ANGLED SPILL
 24 - SHORT STRAIGHT SPILL
 15 - WIRE WRAP

000E1- TIN LEAD VERSION
 E1LF-LEADFREE VERSION

LONGITUDINAL PITCH: 5 - 2.54 mm

PERFORMANCE CLASS:
 4 - DIN 41651 CLASS 3
 5 - DIN 41651 CLASS 2
 6 - DIN 41651 CLASS 1
 8 - AS PER JSS 50810

INSULATOR MATERIAL: 3 - PBT GREY

TECHNICAL SPECIFICATION

INSULATOR MATERIAL — THERMOPLASTIC POLYESTER UL 94V0; GREY

HOUSING CAN WITHSTAND EXPOSURE TO LEADFREE WAVE SOLDERING TEMPERATURE OF 260-265°C FOR STRAIGHT CONNECTORS AS IT IS USED IN CLASSICAL LEAD WAVE SOLDERING AT 235-250° C. FOR ANGLE CONNECTORS PROTECTIVE ADHESIVE OR METALLIC DEVICE TO BE USED AS IN CLASSICAL LEAD WAVE SOLDERING AT 235-250°C.

CONTACT MATERIAL — COPPER ALLOY

PLATING — ACTIVE ZONE - GOLD OVER NICKEL
 — TERMINATION ZONE - SnPb OVER Ni FOR LEADED VERSION.
 — Sn (MATTE TIN) OVER Ni FOR LEAD FREE VERSION.

CURRENT RATING — 1.5A AT 20°C

INSULATION RESISTANCE — ≥5000MΩ AT 100V

CONTACT RESISTANCE — ≤20mΩ

DIELECTRIC WITHSTANDING VOLTAGE — 1000 Vrms

OPERATING TEMPERATURE — -55°C TO +125°C

REFERENCE SPECIFICATION — IEC 603-13 / DIN 41651

PCB DRILLING DETAILS

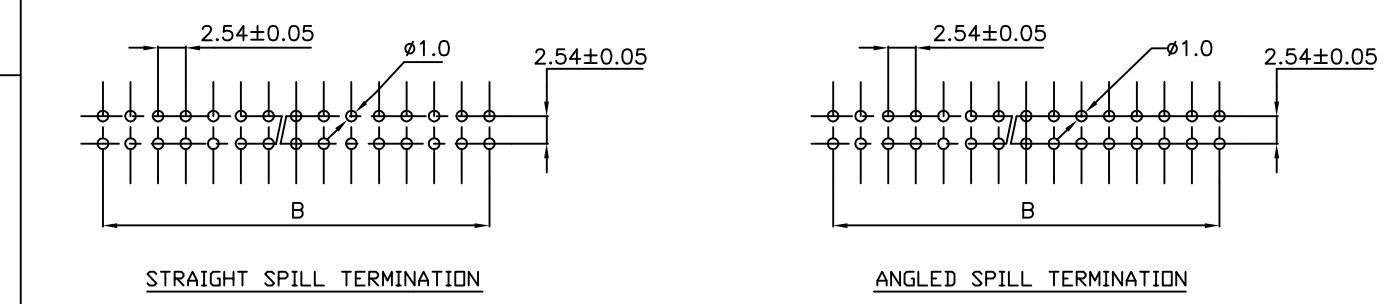

NOTES:

- LEFT POLARISATION IS NOT PROVIDED FOR 10 & 14 POSITIONS.
- RIGHT POLARISATION IS NOT PROVIDED FOR 10 POSITION.
FOR 10 POSITION, INSTEAD OF RIGHT POLARISATION, PROJECTION AS GIVEN IN DETAIL-A WILL BE PROVIDED.
- INTERMEDIATE LEGS ARE PRESENT ONLY ABOVE 20 POSITION.

NOTES:-

- THE "LF" PRODUCTS MEET EUROPEAN UNION DIRECTIVES AND OTHER COUNTRY REGULATIONS AS DESCRIBED IN GS-22-008
- THE HOUSING WILL WITHSTAND EXPOSURE TO 260°C PEAK TEMPERATURE FOR 3.5 SECONDS IN A WAVE SOLDER APPLICATION WITH A 1.6 MM MINIMUM THICK CIRCUIT BOARD
- LEAD FREE OR RoHS DIRECTIVE LABELING TO BE PROVIDED AS PER GS-14-920 FOR RoHS COMPATIBLE VERSION.

mat'l. code		surface		tolerance		projection		product family	
-		ISO 1302		ISO 406 ISO 1101		mm		8613	
ltr		ecn no		dr		date		title	
A		-		MINI		06/12/1998		8613 BOX HEADER	
B		106-0066		MINI		01/06/2006		sheet 1 of 1 size A3	
sheet index		revision sheet		B		1		type Product Customer Drawing	

FCI
FCIconnect.com
Copyright FCI