

# SN54BCT8240A, SN74BCT8240A SCAN TEST DEVICES WITH OCTAL BUFFERS

SCBS067C – FEBRUARY 1990 – REVISED APRIL 1994

- Members of the Texas Instruments **SCOPE™** Family of Testability Products
- Octal Test-Integrated Circuits
- Functionally Equivalent to SN54/74F240 and SN54/74BCT240 in the Normal-Function Mode
- Compatible With the IEEE Standard 1149.1-1990 (JTAG) Test Access Port and Boundary-Scan Architecture
- Test Operation Synchronous to Test Access Port (TAP)
- Implement Optional Test Reset Signal by Recognizing a Double-High-Level Voltage (10 V) on TMS Pin
- **SCOPE™** Instruction Set
  - IEEE Standard 1149.1-1990 Required Instructions, Optional INTEST, CLAMP and HIGHZ
  - Parallel-Signature Analysis at Inputs
  - Pseudo-Random Pattern Generation From Outputs
  - Sample Inputs/Toggle Outputs
- Package Options Include Plastic Small-Outline (DW) Packages, Ceramic Chip Carriers (FK), and Standard Plastic and Ceramic 300-mil DIPs (JT, NT)

## description

The SN54BCT8240A and SN74BCT8240A scan test devices with octal buffers are members of the Texas Instruments SCOPE™ testability integrated circuit family. This family of devices supports IEEE Standard 1149.1-1990 boundary scan to facilitate testing of complex circuit-board assemblies. Scan access to the test circuitry is accomplished via the 4-wire test access port (TAP) interface.

In the normal mode, these devices are functionally equivalent to the SN54/74F240 and SN54/74BCT240 octal buffers. The test circuitry can be activated by the TAP to take snapshot samples of the data appearing at the device terminals or to perform a self test on the boundary-test cells. Activating the TAP in normal mode does not affect the functional operation of the SCOPE™ octal buffers.

In the test mode, the normal operation of the SCOPE™ octal buffers is inhibited and the test circuitry is enabled to observe and control the I/O boundary of the device. When enabled, the test circuitry can perform boundary-scan test operations as described in IEEE Standard 1149.1-1990.

Four dedicated test terminals control the operation of the test circuitry: test data input (TDI), test data output (TDO), test mode select (TMS), and test clock (TCK). Additionally, the test circuitry performs other testing functions such as parallel-signature analysis (PSA) on data inputs and pseudo-random pattern generation (PRPG) from data outputs. All testing and scan operations are synchronized to the TAP interface.

SN54BCT8240A ... JT PACKAGE  
SN74BCT8240A ... DW OR NT PACKAGE  
(TOP VIEW)

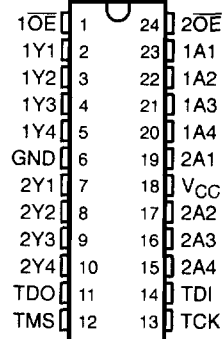

SN54BCT8240A ... FK PACKAGE  
(TOP VIEW)

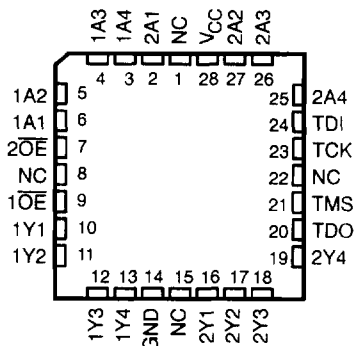

NC – No internal connection

SCOPE is a trademark of Texas Instruments Incorporated.

PRODUCTION DATA Information is current as of publication date. Products conform to specifications per the terms of Texas Instruments standard warranty. Production processing does not necessarily include testing of all parameters.



POST OFFICE BOX 655303 • DALLAS, TEXAS 75265

Copyright © 1994, Texas Instruments Incorporated  
On products compliant to MIL-STD-883, Class B, all parameters are tested unless otherwise noted. On all other products, production processing does not necessarily include testing of all parameters.

**SN54BCT8240A, SN74BCT8240A**  
**SCAN TEST DEVICES**  
**WITH OCTAL BUFFERS**

SCBS067C – FEBRUARY 1990 – REVISED APRIL 1994

**description (continued)**

The SN54BCT8240A is characterized for operation over the full military temperature range of –55°C to 125°C. The SN74BCT8240A is characterized for operation from 0°C to 70°C.

**FUNCTION TABLE**  
 (normal mode, each buffer)

INPUTS		OUTPUT
OE	A	Y
H	X	Z
L	L	H
L	H	L

**logic symbol†**

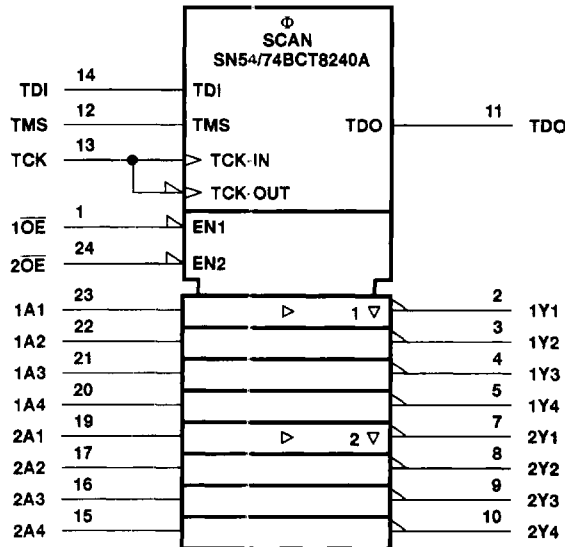

† This symbol is in accordance with ANSI/IEEE Std 91-1984 and EC Publication 617-12. Pin numbers shown are for the DW, JT, and NT packages.

functional block diagram

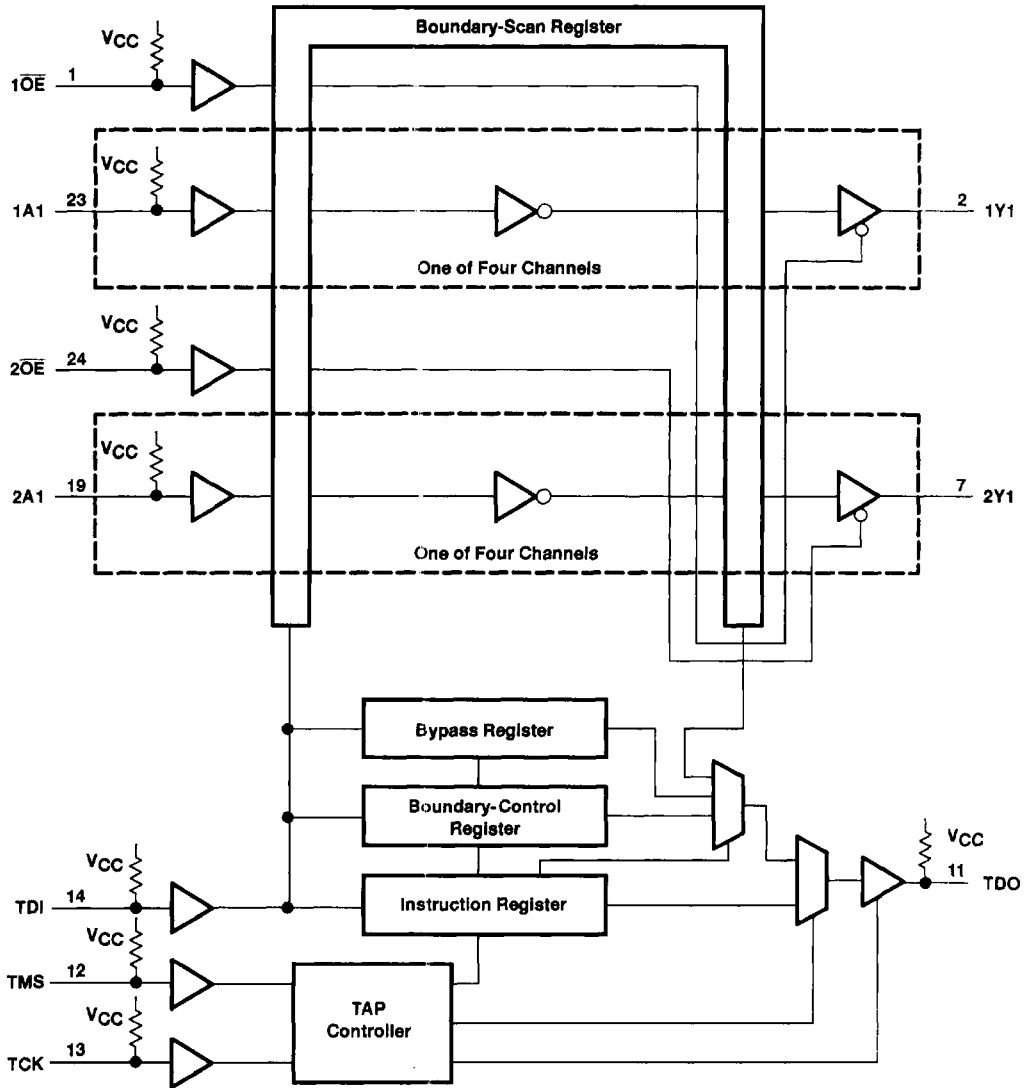

Pin numbers shown are for the DW, JT, and NT packages.

**SN54BCT8240A, SN74BCT8240A**  
**SCAN TEST DEVICES**  
**WITH OCTAL BUFFERS**

SCBS067C – FEBRUARY 1990 – REVISED APRIL 1994

**Terminal Functions**

TERMINAL NAME	DESCRIPTION
1A1–1A4, 2A1–2A4	Normal-function data inputs. See function table for normal-mode logic. Internal pullups force these inputs to a high level if left unconnected.
GND	Ground
1 $\overline{OE}$ , 2 $\overline{OE}$	Normal-function output-enable inputs. See function table for normal-mode logic. Internal pullups force these inputs to a high level if left unconnected.
TCK	Test clock. One of four terminals required by IEEE Standard 1149.1-1990. Test operations of the device are synchronous to TCK. Data is captured on the rising edge of TCK and outputs change on the falling edge of TCK. An internal pullup forces TCK to a high level if left unconnected.
TDI	Test data input. One of four terminals required by IEEE Standard 1149.1-1990. TDI is the serial input for shifting data through the instruction register or selected data register. An internal pullup forces TDI to a high level if left unconnected.
TDO	Test data output. One of four terminals required by IEEE Standard 1149.1-1990. TDO is the serial output for shifting data through the instruction register or selected data register. An internal pullup forces TDO to a high level when it is not active and is not driven from an external source.
TMS	Test mode select. One of four terminals required by IEEE Standard 1149.1-1990. TMS directs the device through its TAP-controller states. An internal pullup forces TMS to a high level if left unconnected. TMS also provides the optional test reset signal of IEEE Standard 1149.1-1990. This is implemented by recognizing a third logic level, double high ( $V_{IH}$ ), at TMS.
VCC	Supply voltage
1Y1–1Y4, 2Y1–2Y4	Normal-function data outputs. See function table for normal-mode logic.

**test architecture**

Serial-test information is conveyed by means of a 4-wire test bus, or TAP, that conforms to IEEE Standard 1149.1-1990. Test instructions, test data, and test control signals all are passed along this serial-test bus. The TAP controller monitors two signals from the test bus, namely TCK and TMS. The TAP controller extracts the synchronization (TCK) and state control (TMS) signals from the test bus and generates the appropriate on-chip control signals for the test structures in the device. Figure 1 shows the TAP-controller state diagram.

The TAP controller is fully synchronous to the TCK signal. Input data is captured on the rising edge of TCK, and output data changes on the falling edge of TCK. This scheme ensures that data to be captured is valid for fully one-half of the TCK cycle.

The functional block diagram illustrates the IEEE Standard 1149.1-1990 4-wire test bus and boundary-scan architecture and the relationship among the test bus, the TAP controller, and the test registers. As illustrated, the device contains an 8-bit instruction register and three test-data registers: an 18-bit boundary-scan register, a 2-bit boundary-control register, and a 1-bit bypass register.

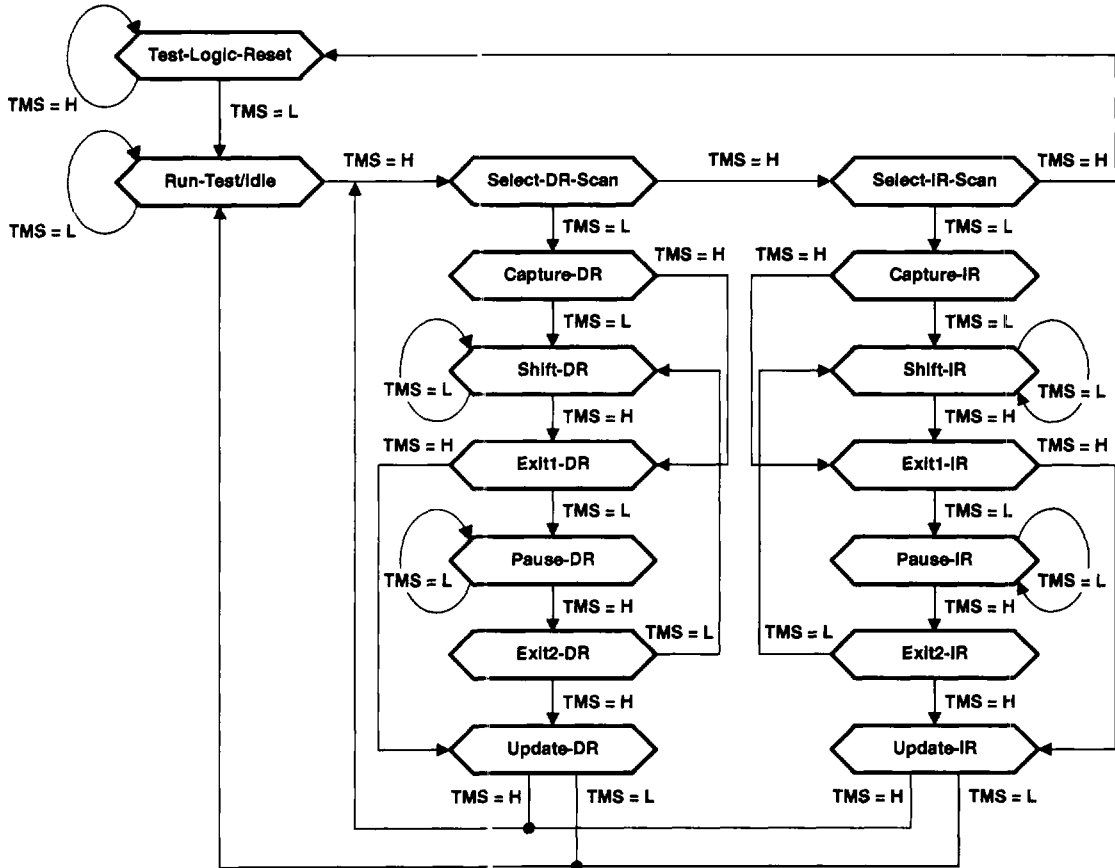

Figure 1. TAP-Controller State Diagram

### **state diagram description**

The TAP controller is a synchronous finite state machine that provides test control signals throughout the device. The state diagram is illustrated in Figure 1 and is in accordance with IEEE Standard 1149.1-1990. The TAP controller proceeds through its states based on the level of TMS at the rising edge of TCK.

As illustrated, the TAP controller consists of 16 states. There are six stable states (indicated by a looping arrow in the state diagram) and ten unstable states. A stable state is a state the TAP controller can retain for consecutive TCK cycles. Any state that does not meet this criterion is an unstable state.

There are two main paths through the state diagram: one to access and control the selected data register and one to access and control the instruction register. Only one register may be accessed at a time.

### **Test-Logic-Reset**

The device powers up in the Test-Logic-Reset state. In the stable Test-Logic-Reset state, the test logic is reset and is disabled so that the normal logic function of the device is performed. The instruction register is reset to an opcode that selects the optional IDCODE instruction, if supported, or the BYPASS instruction. Certain data registers also can be reset to their power-up values.

The state machine is constructed such that the TAP controller returns to the Test-Logic-Reset state in no more than five TCK cycles if TMS is left high. The TMS pin has an internal pullup resistor that forces it high if left unconnected or if a board defect causes it to be open circuited.

For the 'BCT8240A, the instruction register is reset to the binary value 11111111, which selects the BYPASS instruction. The boundary-control register is reset to the binary value 10, which selects the PSA test operation.

### **Run-Test/Idle**

The TAP controller must pass through the Run-Test/Idle state (from Test-Logic-Reset) before executing any test operations. The Run-Test/Idle state also can be entered following data-register or instruction-register scans. Run-Test/Idle is a stable state in which the test logic may be actively running a test or may be idle.

The test operations selected by the boundary-control register are performed while the TAP controller is in the Run-Test/Idle state.

### **Select-DR-Scan, Select-IR-Scan**

No specific function is performed in the Select-DR-Scan and Select-IR-Scan states, and the TAP controller exits either of these states on the next TCK cycle. These states allow the selection of either data-register scan or instruction-register scan.

### **Capture-DR**

When a data-register scan is selected, the TAP controller must pass through the Capture-DR state. In the Capture-DR state, the selected-data register may capture a data value as specified by the current instruction. Such capture operations occur on the rising edge of TCK upon which the TAP controller exits the Capture-DR state.

### **Shift-DR**

Upon entry to the Shift-DR state, the data register is placed in the scan path between TDI and TDO and, on the first falling edge of TCK, TDO goes from the high-impedance state to an active state. TDO enables to the logic level present in the least significant bit of the selected data register.

While in the stable Shift-DR state, data is serially shifted through the selected data register on each TCK cycle. The first shift occurs on the first rising edge of TCK after entry to the Shift-DR state (i.e., no shifting occurs during the TCK cycle in which the TAP controller changes from Capture-DR to Shift-DR or from Exit2-DR to Shift-DR). The last shift occurs on the rising edge of TCK upon which the TAP controller exits the Shift-DR state.

#### **Exit1-DR, Exit2-DR**

The Exit1-DR and Exit2-DR states are temporary states that end a data-register scan. It is possible to return to the Shift-DR state from either Exit1-DR or Exit2-DR without recapturing the data register.

On the first falling edge of TCK after entry to Exit1-DR, TDO goes from the active state to the high-impedance state.

#### **Pause-DR**

No specific function is performed in the stable Pause-DR state, in which the TAP controller can remain indefinitely. The Pause-DR state suspends and resumes data-register scan operations without loss of data.

#### **Update-DR**

If the current instruction calls for the selected data register to be updated with current data, then such update occurs on the falling edge of TCK following entry to the Update-DR state.

#### **Capture-IR**

When an instruction-register scan is selected, the TAP controller must pass through the Capture-IR state. In the Capture-IR state, the instruction register captures its current status value. This capture operation occurs on the rising edge of TCK upon which the TAP controller exits the Capture-IR state.

For the 'BCT8240A, the status value loaded in the Capture-IR state is the fixed binary value 10000001.

#### **Shift-IR**

Upon entry to the Shift-IR state, the instruction register is placed in the scan path between TDI and TDO and, on the first falling edge of TCK, TDO goes from the high-impedance state to an active state. TDO enables to the logic level present in the least significant bit of the instruction register.

While in the stable Shift-IR state, instruction data is serially shifted through the instruction register on each TCK cycle. The first shift occurs on the first rising edge of TCK after entry to the Shift-IR state (i.e., no shifting occurs during the TCK cycle in which the TAP controller changes from Capture-IR to Shift-IR or from Exit2-IR to Shift-IR). The last shift occurs on the rising edge of TCK upon which the TAP controller exits the Shift-IR state.

#### **Exit1-IR, Exit2-IR**

The Exit1-IR and Exit2-IR states are temporary states that end an instruction-register scan. It is possible to return to the Shift-IR state from either Exit1-IR or Exit2-IR without recapturing the instruction register.

On the first falling edge of TCK after entry to Exit1-IR, TDO goes from the active state to the high-impedance state.

#### **Pause-IR**

No specific function is performed in the stable Pause-IR state, in which the TAP controller can remain indefinitely. The Pause-IR state suspends and resumes instruction-register scan operations without loss of data.

#### **Update-IR**

The current instruction is updated and takes effect on the falling edge of TCK following entry to the Update-IR state.

## register overview

With the exception of the bypass register, any test register may be thought of as a serial-shift register with a shadow latch on each bit. The bypass register differs in that it contains only a shift register. During the appropriate capture state (Capture-IR for instruction register, Capture-DR for data registers), the shift register may be parallel loaded from a source specified by the current instruction. During the appropriate shift state (Shift-IR or Shift-DR), the contents of the shift register are shifted out from TDO while new contents are shifted in at TDI. During the appropriate update state (Update-IR or Update-DR), the shadow latches are updated from the shift register.

## instruction register description

The instruction register (IR) is eight bits long and tells the device what instruction is to be executed. Information contained in the instruction includes the mode of operation (either normal mode, in which the device performs its normal logic function, or test mode, in which the normal logic function is inhibited or altered), the test operation to be performed, which of the three data registers is to be selected for inclusion in the scan path during data-register scans, and the source of data to be captured into the selected data register during Capture-DR.

Table 2 lists the instructions supported by the 'BCT8240A. The even-parity feature specified for SCOPE™ devices is not supported in this device. Bit 7 of the instruction opcode is a don't-care bit. Any instructions that are defined for SCOPE™ devices but are not supported by this device default to BYPASS.

During Capture-IR, the IR captures the binary value 10000001. As an instruction is shifted in, this value is shifted out via TDO and can be inspected as verification that the IR is in the scan path. During Update-IR, the value that has been shifted into the IR is loaded into shadow latches. At this time, the current instruction is updated and any specified mode change takes effect. At power up or in the Test-Logic-Reset state, the IR is reset to the binary value 11111111, which selects the BYPASS instruction. The IR order of scan is illustrated in Figure 2.

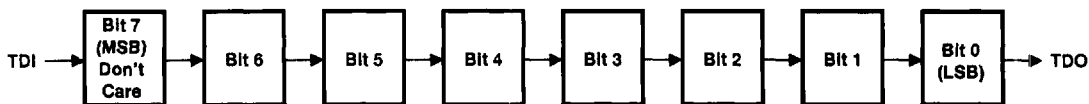

Figure 2. Instruction Register Order of Scan



**data-register description**

**boundary-scan register**

The boundary-scan register (BSR) is 18 bits long. It contains one boundary-scan cell (BSC) for each normal-function input pin and one BSC for each normal-function output pin. The BSR is used 1) to store test data that is to be applied internally to the inputs of the normal on-chip logic and/or externally to the device output terminals, and/or 2) to capture data that appears internally at the outputs of the normal on-chip logic and/or externally at the device input terminals.

The source of data to be captured into the BSR during Capture-DR is determined by the current instruction. The contents of the BSR may change during Run-Test/Idle as determined by the current instruction. The contents of the BSR are not changed in Test-Logic-Reset.

The BSR order of scan is from TDI through bits 17-0 to TDO. Table 1 shows the BSR bits and their associated device pin signals.

**Table 1. Boundary-Scan-Register Configuration**

BSR BIT NUMBER	DEVICE SIGNAL	BSR BIT NUMBER	DEVICE SIGNAL	BSR BIT NUMBER	DEVICE SIGNAL
17	1OE	15	1A1	7	1Y1
16	2OE	14	1A2	6	1Y2
—	—	13	1A3	5	1Y3
—	—	12	1A4	4	1Y4
—	—	11	2A1	3	2Y1
—	—	10	2A2	2	2Y2
—	—	9	2A3	1	2Y3
—	—	8	2A4	0	2Y4

**boundary-control register**

The boundary-control register (BCR) is two bits long. The BCR is used in the context of the RUNT instruction to implement additional test operations not included in the basic SCOPE™ instruction set. Such operations include PRPG and PSA. Table 3 shows the test operations that are decoded by the BCR.

During Capture-DR, the contents of the BCR are not changed. At power up or in Test-Logic-Reset, the BCR is reset to the binary value 10, which selects the PSA test operation. The BCR order of scan is illustrated in Figure 3.

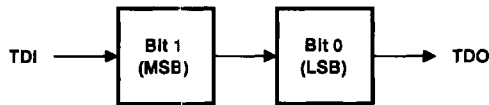

**Figure 3. Boundary-Control Register Order of Scan**

**SN54BCT8240A, SN74BCT8240A**  
**SCAN TEST DEVICES**  
**WITH OCTAL BUFFERS**

SCBS067C – FEBRUARY 1990 – REVISED APRIL 1994

**bypass register**

The bypass register is a 1-bit scan path that can be selected to shorten the length of the system scan path, thereby reducing the number of bits per test pattern that must be applied to complete a test operation.

During Capture-DR, the bypass register captures a logic 0. The bypass register order of scan is illustrated in Figure 4.

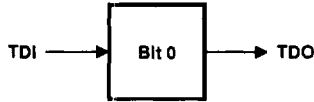

**Figure 4. Bypass Register Order of Scan**

**instruction-register opcode description**

The instruction-register opcodes are shown in Table 2. The following descriptions detail the operation of each instruction.

**Table 2. Instruction-Register Opcodes**

BINARY CODE† BIT 7 → BIT 0 MSB → LSB	SCOPE OPCODE	DESCRIPTION	SELECTED DATA REGISTER	MODE
X0000000	EXTTEST	Boundary scan	Boundary scan	Test
X0000001	BYPASS‡	Bypass scan	Bypass	Normal
X0000010	SAMPLE/PRELOAD	Sample boundary	Boundary scan	Normal
X0000011	INTEST	Boundary scan	Boundary scan	Test
X0000100	BYPASS‡	Bypass scan	Bypass	Normal
X0000101	BYPASS‡	Bypass scan	Bypass	Normal
X0000110	HIGHZ (TRIBYP)	Control boundary to high impedance	Bypass	Modified test
X0000111	CLAMP (SETBYP)	Control boundary to 1/0	Bypass	Test
X0001000	BYPASS‡	Bypass scan	Bypass	Normal
X0001001	RUNT	Boundary run test	Bypass	Test
X0001010	READBN	Boundary read	Boundary scan	Normal
X0001011	READBT	Boundary read	Boundary scan	Test
X0001100	CELLTST	Boundary self test	Boundary scan	Normal
X0001101	TOPHIP	Boundary toggle outputs	Bypass	Test
X0001110	SCANCN	Boundary-control register scan	Boundary control	Normal
X0001111	SCANCT	Boundary-control register scan	Boundary control	Test
All others	BYPASS	Bypass scan	Bypass	Normal

† Bit 7 is a don't-care bit; X = don't care.

‡ The BYPASS instruction is executed in lieu of a SCOPE™ instruction that is not supported in the BCT8240A.



#### **boundary scan**

This instruction conforms to the IEEE Standard 1149.1-1990 EXTEST and INTEST instructions. The BSR is selected in the scan path. Data appearing at the device input terminals is captured in the input BSCs, while data appearing at the outputs of the normal on-chip logic is captured in the output BSCs. Data that has been scanned into the input BSCs is applied to the inputs of the normal on-chip logic, while data that has been scanned into the output BSCs is applied to the device output terminals. The device operates in the test mode.

#### **bypass scan**

This instruction conforms to the IEEE Standard 1149.1-1990 BYPASS instruction. The bypass register is selected in the scan path. A logic 0 value is captured in the bypass register during Capture-DR. The device operates in the normal mode.

#### **sample boundary**

This instruction conforms to the IEEE Standard 1149.1-1990 SAMPLE/PRELOAD instruction. The BSR is selected in the scan path. Data appearing at the device input terminals is captured in the input BSCs, while data appearing at the outputs of the normal on-chip logic is captured in the output BSCs. The device operates in the normal mode.

#### **control boundary to high impedance**

This instruction conforms to the IEEE Standard 1149.1a-1993 HIGHZ instruction. The bypass register is selected in the scan path. A logic 0 value is captured in the bypass register during Capture-DR. The device operates in a modified test mode in which all device output terminals are placed in the high-impedance state, the device input terminals remain operational, and the normal on-chip logic function is performed.

#### **control boundary to 1/0**

This instruction conforms to the IEEE Standard 1149.1a-1993 CLAMP instruction. The bypass register is selected in the scan path. A logic 0 value is captured in the bypass register during Capture-DR. Data in the input BSCs is applied to the inputs of the normal on-chip logic, while data in the output BSCs is applied to the device output terminals. The device operates in the test mode.

#### **boundary run test**

The bypass register is selected in the scan path. A logic 0 value is captured in the bypass register during Capture-DR. The device operates in the test mode. The test operation specified in the BCR is executed during Run-Test/Idle. The four test operations decoded by the BCR are: sample inputs/toggle outputs (TOPSIP), PRPG, PSA, and simultaneous PSA and PRPG (PSA/PRPG).

#### **boundary read**

The BSR is selected in the scan path. The value in the BSR remains unchanged during Capture-DR. This instruction is useful for inspecting data after a PSA operation.

#### **boundary self test**

The BSR is selected in the scan path. All BSCs capture the inverse of their current values during Capture-DR. In this way, the contents of the shadow latches may be read out to verify the integrity of both shift-register and shadow-latch elements of the BSR. The device operates in the normal mode.

# SN54BCT8240A, SN74BCT8240A

## SCAN TEST DEVICES WITH OCTAL BUFFERS

SCBS067C – FEBRUARY 1990 – REVISED APRIL 1994

---

### boundary toggle outputs

The bypass register is selected in the scan path. A logic 0 value is captured in the bypass register during Capture-DR. Data in the shift-register elements of the selected output BSCs is toggled on each rising edge of TCK in Run-Test/Idle and is then updated in the shadow latches and applied to the associated device output terminals on each falling edge of TCK in Run-Test/Idle. Data in the selected input BSCs remains constant and is applied to the inputs of the normal on-chip logic. Data appearing at the device input terminals is not captured in the input BSCs. The device operates in the test mode.

### boundary-control-register scan

The BCR is selected in the scan path. The value in the BCR remains unchanged during Capture-DR. This operation must be performed before a boundary-run test operation to specify which test operation is to be executed.

### boundary-control-register opcode description

The BCR opcodes are decoded from BCR bits 1–0 as shown in Table 3. The selected test operation is performed while the RUNT instruction is executed in the Run-Test/Idle state. The following descriptions detail the operation of each BCR instruction and illustrate the associated PSA and PRPG algorithms.

**Table 3. Boundary-Control-Register Opcodes**

BINARY CODE BIT 1 → BIT 0 MSB → LSB	DESCRIPTION
00	Sample inputs/toggle outputs (TOPSIP)
01	Pseudo-random pattern generation/16-bit mode (PRPG)
10	Parallel-signature analysis/16-bit mode (PSA)
11	Simultaneous PSA and PRPG/8-bit mode (PSA/PRPG)

It should be noted, in general, that while the control input BSCs (bits 17–16) are not included in the sample, toggle, PSA, or PRPG algorithms, the output-enable BSCs (bits 17–16 of the BSR) do control the drive state (active or high impedance) of the selected device output terminals.

### sample inputs/toggle outputs (TOPSIP)

Data appearing at the device input terminals is captured in the shift-register elements of the input BSCs on each rising edge of TCK. This data is then updated in the shadow latches of the input BSCs and applied to the inputs of the normal on-chip logic. Data in the shift-register elements of the output BSCs is toggled on each rising edge of TCK, updated in the shadow latches, and applied to the device output terminals on each falling edge of TCK.



POST OFFICE BOX 655303 • DALLAS, TEXAS 75265

**pseudo-random pattern generation (PRPG)**

A pseudo-random pattern is generated in the shift-register elements of the BSCs on each rising edge of TCK and then updated in the shadow latches and applied to the device output terminals on each falling edge of TCK. This data also is updated in the shadow latches of the input BSCs and applied to the inputs of the normal on-chip logic. Figure 5 illustrates the 16-bit linear-feedback shift-register algorithm through which the patterns are generated. An initial seed value should be scanned into the BSR before performing this operation. A seed value of all zeroes will not produce additional patterns.

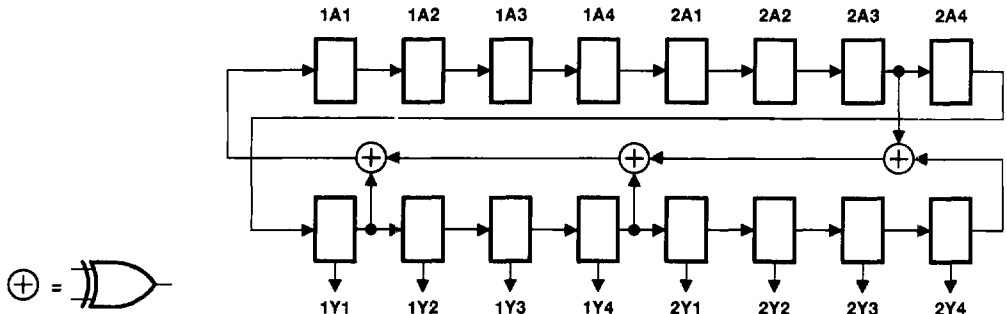

**Figure 5. 16-Bit PRPG Configuration**

**parallel-signature analysis (PSA)**

Data appearing at the device input terminals is compressed into a 16-bit parallel signature in the shift-register elements of the BSCs on each rising edge of TCK. This data is then updated in the shadow latches of the input BSCs and applied to the inputs of the normal on-chip logic. Data in the shadow latches of the output BSCs remains constant and is applied to the device outputs. Figure 6 illustrates the 16-bit linear-feedback shift-register algorithm through which the signature is generated. An initial seed value should be scanned into the BSR before performing this operation.

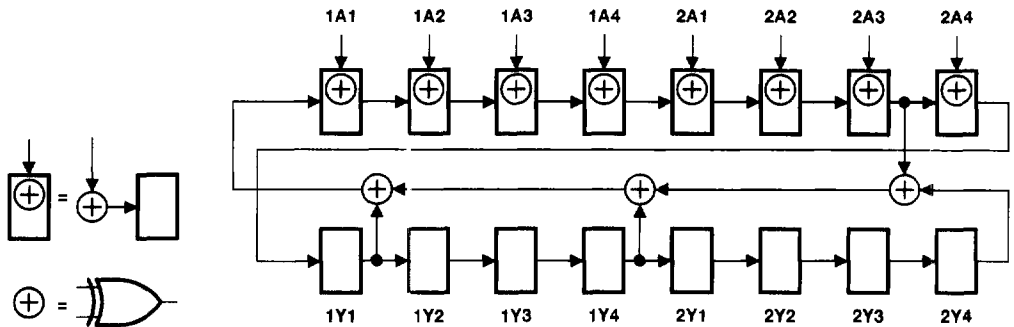

**Figure 6. 16-Bit PSA Configuration**

**SN54BCT8240A, SN74BCT8240A**  
**SCAN TEST DEVICES**  
**WITH OCTAL BUFFERS**

SCBS067C – FEBRUARY 1990 – REVISED APRIL 1994

**simultaneous PSA and PRPG (PSA/PRPG)**

Data appearing at the device input terminals is compressed into an 8-bit parallel signature in the shift-register elements of the input BSCs on each rising edge of TCK. This data is then updated in the shadow latches of the input BSCs and applied to the inputs of the normal on-chip logic. At the same time, an 8-bit pseudo-random pattern is generated in the shift-register elements of the output BSCs on each rising edge of TCK, updated in the shadow latches, and applied to the device output terminals on each falling edge of TCK. Figure 7 illustrates the 8-bit linear-feedback shift-register algorithm through which the signature and patterns are generated. An initial seed value should be scanned into the BSR before performing this operation. A seed value of all zeroes will not produce additional patterns.

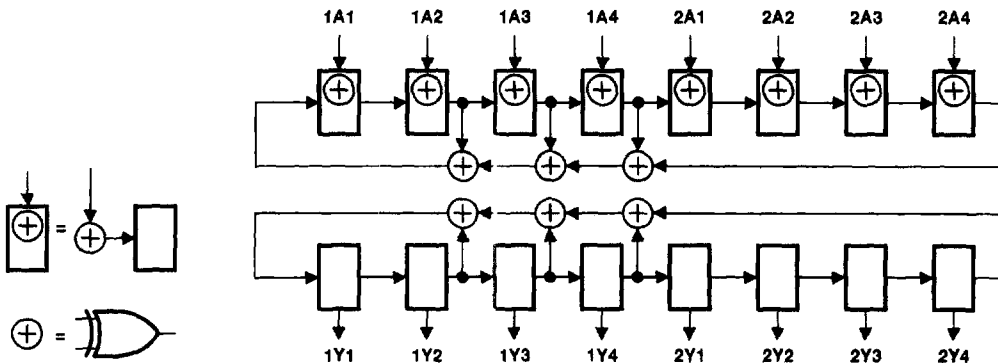

**Figure 7. 8-Bit PSA/PRPG Configuration**

**timing description**

All test operations of the BCT8240A are synchronous to TCK. Data on the TDI, TMS, and normal-function inputs is captured on the rising edge of TCK. Data appears on the TDO and normal-function output terminals on the falling edge of TCK. The TAP controller is advanced through its states (as illustrated in Figure 1) by changing the value of TMS on the falling edge of TCK and then applying a rising edge to TCK.

A simple timing example is illustrated in Figure 8. In this example, the TAP controller begins in the Test-Logic-Reset state and is advanced through its states as necessary to perform one instruction-register scan and one data-register scan. While in the Shift-IR and Shift-DR states, TDI is used to input serial data and TDO is used to output serial data. The TAP controller is then returned to the Test-Logic-Reset state. Table 4 explains the operation of the test circuitry during each TCK cycle.

**Table 4. Explanation of Timing Example**

TCK CYCLE(S)	TAP STATE AFTER TCK	DESCRIPTION
1	Test-Logic-Reset	TMS is changed to a logic 0 value on the falling edge of TCK to begin advancing the TAP controller toward the desired state.
2	Run-Test/Idle	
3	Select-DR-Scan	
4	Select-IR-Scan	
5	Capture-IR	The IR captures the 8-bit binary value 10000001 on the rising edge of TCK as the TAP controller exits the Capture-IR state.
6	Shift-IR	TDO becomes active and TDI is made valid on the falling edge of TCK. The first bit is shifted into the TAP on the rising edge of TCK as the TAP controller advances to the next state.
7-13	Shift-IR	One bit is shifted into the IR on each TCK rising edge. With TDI held at a logic 1 value, the 8-bit binary value 11111111 is serially scanned into the IR. At the same time, the 8-bit binary value 10000001 is serially scanned out of the IR via TDO. In TCK cycle 13, TMS is changed to a logic 1 value to end the IR scan on the next TCK cycle. The last bit of the instruction is shifted as the TAP controller advances from Shift-IR to Exit1-IR.
14	Exit1-IR	TDO becomes inactive (goes to the high-impedance state) on the falling edge of TCK.
15	Update-IR	The IR is updated with the new instruction (BYPASS) on the falling edge of TCK.
16	Select-DR-Scan	
17	Capture-DR	The bypass register captures a logic 0 value on the rising edge of TCK as the TAP controller exits the Capture-DR state.
18	Shift-DR	TDO becomes active and TDI is made valid on the falling edge of TCK. The first bit is shifted into the TAP on the rising edge of TCK as the TAP controller advances to the next state.
19-20	Shift-DR	The binary value 101 is shifted in via TDI, while the binary value 010 is shifted out via TDO.
21	Exit1-DR	TDO becomes inactive (goes to the high-impedance state) on the falling edge of TCK.
22	Update-DR	In general, the selected data register is updated with the new data on the falling edge of TCK.
23	Select-DR-Scan	
24	Select-IR-Scan	
25	Test-Logic-Reset	Test operation completed

# SN54BCT8240A, SN74BCT8240A SCAN TEST DEVICES WITH OCTAL BUFFERS

SCBS067C – FEBRUARY 1990 – REVISED APRIL 1994

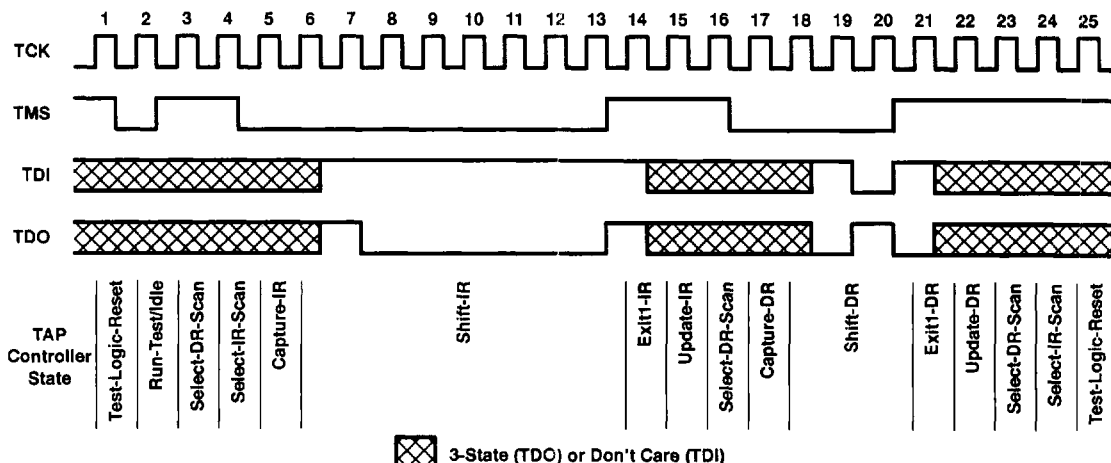

**Figure 8. Timing Example**

## absolute maximum ratings over operating free-air temperature range (unless otherwise noted)†

Supply voltage range, $V_{CC}$ .....	-0.5 V to 7 V
Input voltage range, $V_I$ : except TMS (see Note 1) .....	-0.5 V to 7 V
TMS (see Note 1) .....	-0.5 V to 12 V
Voltage range applied to any output in the disabled or power-off state .....	-0.5 V to 5.5 V
Voltage range applied to any output in the high state .....	-0.5 V to $V_{CC}$
Input clamp current, $I_{IK}$ .....	-30 mA
Current into any output in the low state:	
SN54ECT8240A (TDO) .....	40 mA
SN54ECT8240A (any Y) .....	96 mA
SN74ECT8240A (TDO) .....	48 mA
SN74ECT8240A (any Y) .....	128 mA
Storage temperature range .....	-65°C to 150°C

† Stresses beyond those listed under “absolute maximum ratings” may cause permanent damage to the device. These are stress ratings only, and functional operation of the device at these or any other conditions beyond those indicated under “recommended operating conditions” is not implied. Exposure to absolute-maximum-rated conditions for extended periods may affect device reliability.

NOTE 1: The input voltage rating may be exceeded if the input clamp-current rating is observed.



**SN54BCT8240A, SN74BCT8240A**  
**SCAN TEST DEVICES**  
**WITH OCTAL BUFFERS**

SCBS067C - FEBRUARY 1990 - REVISED APRIL 1994

**recommended operating conditions**

		SN54BCT8240A			SN74BCT8240A			UNIT
		MIN	NOM	MAX	MIN	NOM	MAX	
V <sub>CC</sub>	Supply voltage	4.5	5	5.5	4.5	5	5.5	V
V <sub>IH</sub>	High-level input voltage	2			2			V
V <sub>IHH</sub>	Double-high-level input voltage			12	10		12	V
V <sub>IL</sub>	Low-level input voltage			0.8			0.8	V
I <sub>IK</sub>	Input clamp current			-18			-18	mA
I <sub>OH</sub>	High-level output current	TDO		-3			-3	mA
		Any Y		-12			-15	
I <sub>OL</sub>	Low-level output current	TDO		20			24	mA
		Any Y		48			64	
T <sub>A</sub>	Operating free-air temperature	-55		125	0		70	°C

**electrical characteristics over recommended operating free-air temperature range (unless otherwise noted)**

PARAMETER		TEST CONDITIONS		SN54BCT8240A			SN74BCT8240A			UNIT
				MIN	TYP†	MAX	MIN	TYP†	MAX	
V <sub>IK</sub>		V <sub>CC</sub> = 4.5 V, I <sub>I</sub> = -18 mA			-1.2			-1.2	V	
V <sub>OH</sub>	Any Y	V <sub>CC</sub> = 4.75 V, I <sub>OH</sub> = -3 mA	2.7	3.4		2.7	3.4	V		
		V <sub>CC</sub> = 4.5 V	I <sub>OH</sub> = -3 mA	2.4	3.4		2.4		3.4	
			I <sub>OH</sub> = -12 mA	2	3.2					
			I <sub>OH</sub> = -15 mA				2		3.1	
	TDO	V <sub>CC</sub> = 4.75 V, I <sub>OH</sub> = -1 mA	2.7	3.4		2.7	3.4	V		
V <sub>OL</sub>	Any Y	V <sub>CC</sub> = 4.5 V	I <sub>OL</sub> = 48 mA	0.38	0.55			V		
			I <sub>OL</sub> = 64 mA				0.42		0.55	
	TDO	V <sub>CC</sub> = 4.5 V	I <sub>OL</sub> = 20 mA	0.3	0.5					
			I <sub>OL</sub> = 24 mA				0.35	0.5		
I <sub>I</sub>		V <sub>CC</sub> = 5.5 V, V <sub>I</sub> = 5.5 V			0.1			0.1	mA	
I <sub>IH</sub>		V <sub>CC</sub> = 5.5 V, V <sub>I</sub> = 2.7 V	-1	-35	-100	-1	-35	-100	μA	
I <sub>IHH</sub>		TMS V <sub>CC</sub> = 5.5 V, V <sub>I</sub> = 10 V			1			1	mA	
I <sub>IL</sub>		V <sub>CC</sub> = 5.5 V, V <sub>I</sub> = 0.5 V			-70			-200	μA	
I <sub>OZH</sub>	Any Y	V <sub>CC</sub> = 5.5 V, V <sub>O</sub> = 2.7 V			50			50	μA	
	TDO				-1	-35	-100	-1		-35
I <sub>OZL</sub>	Any Y	V <sub>CC</sub> = 5.5 V, V <sub>O</sub> = 0.5 V			-50			-50	μA	
	TDO				-70			-200		
I <sub>OS</sub> ‡		V <sub>CC</sub> = 5.5 V, V <sub>O</sub> = 0	-100		-225	-100		-225	mA	
I <sub>CC</sub>	V <sub>CC</sub> = 5.5 V, Outputs open		Outputs high	3.5	7.5		3.5	7.5	mA	
			Outputs low	35	52		35	52		
			Outputs disabled	1.5	3.5		1.5	3.5		
C <sub>I</sub>		V <sub>CC</sub> = 5 V, V <sub>I</sub> = 2.5 V or 0.5 V			10			10	pF	

**SN54BCT8240A, SN74BCT8240A**

**SCAN TEST DEVICES  
WITH OCTAL BUFFERS**

SCBS067C – FEBRUARY 1990 – REVISED APRIL 1994

**timing requirements over recommended ranges of supply voltage and operating free-air temperature (unless otherwise noted) (test mode) (see Figure 9)**

			VCC = 5 V, TA = 25°C		SN54BCT8240A		SN74BCT8240A		UNIT
			MIN	MAX	MIN	MAX	MIN	MAX	
$f_{clock}$	Clock frequency	TCK	0	20	0	20	0	20	MHz
$t_w$	Pulse duration	TCK high or low	25		25		25		ns
		TMS double high	50*		50*		50		
$t_{su}$	Setup time	Any A before TCK↑	6		6		6		ns
		Any $\overline{OE}$ before TCK↑	6		6		6		
		TDI before TCK↑	6		6		6		
		TMS before TCK↑	12		12		12		
$t_h$	Hold time	Any A after TCK↑	4.5		4.5		4.5		ns
		Any $\overline{OE}$ after TCK↑	4.5		4.5		4.5		
		TDI after TCK↑	4.5		4.5		4.5		
		TMS after TCK↑	0		0		0		
$t_d$	Delay time	Power up to TCK↑	100*		100*		100		ns

\* On products compliant to MIL-STD-883, Class B, this parameter is not production tested.



**SN54BCT8240A, SN74BCT8240A**  
**SCAN TEST DEVICES**  
**WITH OCTAL BUFFERS**

SCBS067C - FEBRUARY 1990 - REVISED APRIL 1994

**switching characteristics over recommended ranges of supply voltage and operating free-air temperature (unless otherwise noted) (normal mode) (see Figure 9)**

PARAMETER	FROM (INPUT)	TO (OUTPUT)	V <sub>CC</sub> = 5 V, T <sub>A</sub> = 25°C			SN54BCT8240A		SN74BCT8240A		UNIT
			MIN	TYP	MAX	MIN	MAX	MIN	MAX	
t <sub>PLH</sub>	A	Y	2.5	5.7	7.5	2.5	10	2.5	9	ns
t <sub>PHL</sub>			2.5	5.2	7	2.5	9	2.5	8	
t <sub>PZH</sub>	OE	Y	3	6	8	3	10	3	9.5	ns
t <sub>PZL</sub>			3.5	7	9	3.5	12	3.5	11	
t <sub>PHZ</sub>	OE	Y	2.5	6	8	2.5	10	2.5	9	ns
t <sub>PLZ</sub>			2.5	5.5	8	2.5	10	2.5	9	

**switching characteristics over recommended ranges of supply voltage and operating free-air temperature (unless otherwise noted) (test mode) (see Figure 9)**

PARAMETER	FROM (INPUT)	TO (OUTPUT)	V <sub>CC</sub> = 5 V, T <sub>A</sub> = 25°C			SN54BCT8240A		SN74BCT8240A		UNIT
			MIN	TYP	MAX	MIN	MAX	MIN	MAX	
f <sub>max</sub>	TCK		20			20		20	MHz	
t <sub>PLH</sub>	TCK↓	Y	6	13	15.5	6	21.5	6	20	ns
t <sub>PHL</sub>			6	12.5	15.5	6	21.5	6	20	
t <sub>PLH</sub>	TCK↓	TDO	3.5	7.6	10.5	3.5	14	3.5	13	ns
t <sub>PHL</sub>			3.5	8	10.5	3.5	13	3.5	12	
t <sub>PLH</sub>	TCK↑	Y	7.5	16.5	20	7.5	28	7.5	24	ns
t <sub>PHL</sub>			7.5	17	21	7.5	29	7.5	25	
t <sub>PZH</sub>	TCK↓	Y	6.5	14	17	6.5	24	6.5	21	ns
t <sub>PZL</sub>			7	15	20	7	26	7	23	
t <sub>PZH</sub>	TCK↓	TDO	3.5	7.6	10.5	3.5	11.5	3.5	11	ns
t <sub>PZL</sub>			4	8.5	11	4	13.5	4	12.5	
t <sub>PZH</sub>	TCK↑	Y	8	18	22	8	30	8	27	ns
t <sub>PZL</sub>			8	19	25	8	32	8	29	
t <sub>PHZ</sub>	TCK↓	Y	6	14	18	6	24	6	22	ns
t <sub>PLZ</sub>			6	14	17	6	23	6	21	
t <sub>PHZ</sub>	TCK↓	TDO	3	8	11.5	3	13	3	12.5	ns
t <sub>PLZ</sub>			3	7.5	10	3	13	3	12	
t <sub>PHZ</sub>	TCK↑	Y	8	18.5	22	8	31	8	27	ns
t <sub>PLZ</sub>			8	18.5	22	8	31	8	27	



**SN54BCT8240A, SN74BCT8240A**  
**SCAN TEST DEVICES**  
**WITH OCTAL BUFFERS**

SCBS067C - FEBRUARY 1990 - REVISED APRIL 1994

**PARAMETER MEASUREMENT INFORMATION**

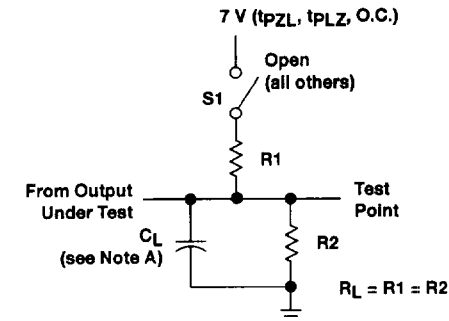

**LOAD CIRCUIT FOR 3-STATE AND OPEN-COLLECTOR OUTPUTS**

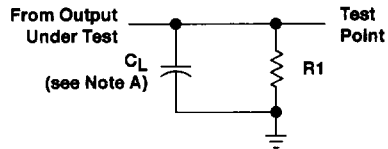

**LOAD CIRCUIT FOR TOTEM-POLE OUTPUTS**

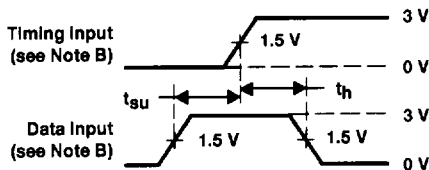

**VOLTAGE WAVEFORMS SETUP AND HOLD TIMES**

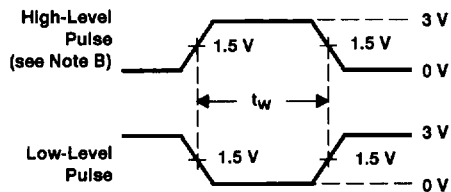

**VOLTAGE WAVEFORMS PULSE DURATION**

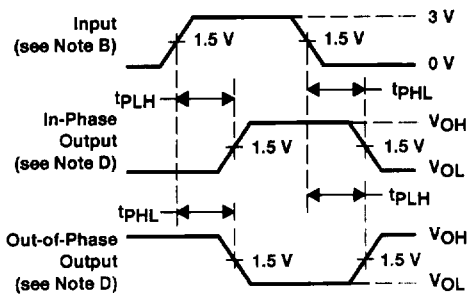

**VOLTAGE WAVEFORMS PROPAGATION DELAY TIMES (see Note D)**

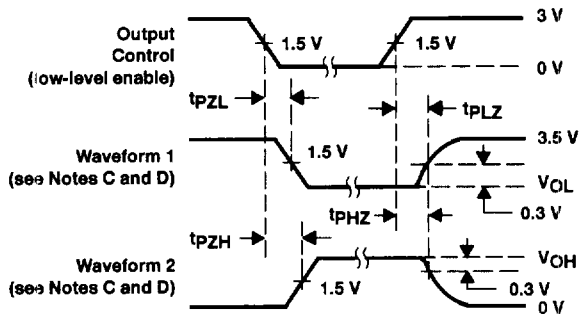

**VOLTAGE WAVEFORMS ENABLE AND DISABLE TIMES, 3-STATE OUTPUTS**

- NOTES: A.  $C_L$  includes probe and jig capacitance.  
 B. All input pulses are supplied by generators having the following characteristics:  $PRR \leq 10$  MHz,  $t_r = t_f \leq 2.5$  ns, duty cycle = 50%.  
 C. Waveform 1 is for an output with internal conditions such that the output is low except when disabled by the output control. Waveform 2 is for an output with internal conditions such that the output is high except when disabled by the output control.  
 D. The outputs are measured one at a time with one transition per measurement.  
 E. When measuring propagation delay times of 3-state outputs, switch S1 is open.

**Figure 9. Load Circuits and Voltage Waveforms**