

50mA, 100mA, and 150mA CMOS LDOs WITH SHUTDOWN AND ERROR OUTPUT

FEATURES

- Zero Ground Current for Longer Battery Life
- Very Low Dropout Voltage
- Guaranteed 50 mA, 100 mA, and 150 mA Output (TC1054, TC1055, and TC1186, Respectively)
- High Output Voltage Accuracy
- Standard or Custom Output Voltages
- Power-Saving Shutdown Mode
- ERROR Output Can Be Used as a Low Battery Detector, or Processor Reset Generator
- Over-Current and Over-Temperature Protection
- Space-Saving SOT-23A-5 Package
- Pin Compatible Upgrades for Bipolar Regulators

APPLICATIONS

- Battery Operated Systems
- Portable Computers
- Medical Instruments
- Instrumentation
- Cellular/GSMS/PHS Phones
- Linear Post-Regulators for SMPS
- Pagers

ORDERING INFORMATION

| Part Number | Package | Junction Temp. Range |
|--------------|------------|----------------------|
| TC1054-xxVCH | SOT-23A-5* | -40°C to +125°C |
| TC1055-xxVCH | SOT-23A-5* | -40°C to +125°C |
| TC1186-xxVCH | SOT-23A-5* | -40°C to +125°C |

TC105EV Evaluation Kit for CMOS LDO Family

NOTE: *SOT-23A-5 is equivalent to the EIAJ (SC-74A).

Available Output Voltages:

2.5, 2.7, 2.8, 2.85, 3.0, 3.3, 3.6, 4.0, 5.0
xx indicates output voltages

Other output voltages are available. Please contact TelCom Semiconductor for details.

PIN CONFIGURATION

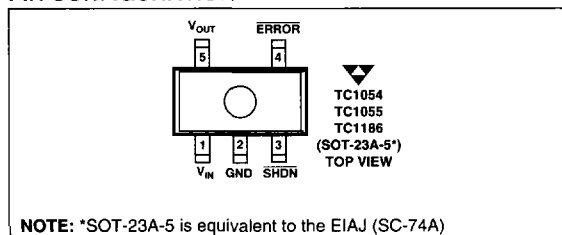

GENERAL DESCRIPTION

The TC1054, TC1055, and TC1186 are high accuracy (typically $\pm 0.5\%$) CMOS upgrades for older (bipolar) low dropout regulators. Designed specifically for battery-operated systems, the devices' CMOS construction eliminates wasted ground current, significantly extending battery life. Total supply current is typically 50 μA at full load (20 to 60 times lower than in bipolar regulators!).

The devices' key features include ultra low noise operation, very low dropout voltage — typically 85 mV (TC1054); 180 mV (TC1055); and 270 mV (TC1186) at full load — and fast response to step changes in load. An error output ($\overline{\text{ERROR}}$) is asserted when the devices are out-of-regulation (due to a low input voltage or excessive output current). ERROR can be used as a low battery warning or as a processor $\overline{\text{RESET}}$ signal (with the addition of an external RC network). Supply current is reduced to 0.5 μA (max) and both V_{OUT} and ERROR are disabled when the shutdown input is low. The devices incorporate both over-temperature and over-current protection.

The TC1054, TC1055, and TC1186 are stable with an output capacitor of only 1 μF and have a maximum output current of 50mA, 100mA, and 150mA, respectively. For higher output current regulators, please see the TC1173 ($I_{\text{OUT}} = 300\text{mA}$) data sheet.

TYPICAL APPLICATION

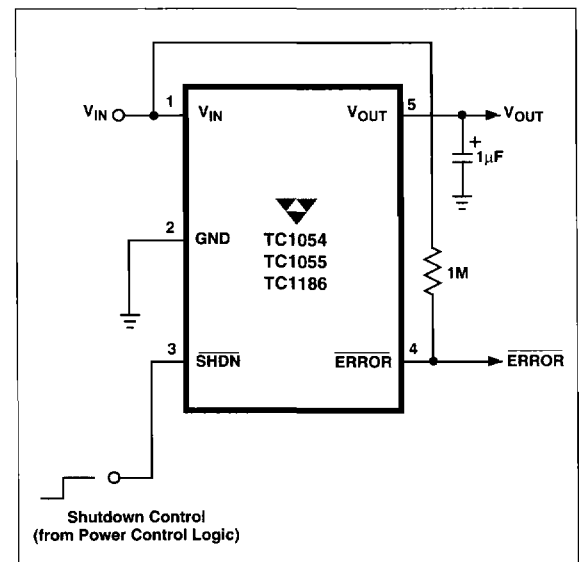

50mA, 100 mA, AND 150 mA CMOS LDOs WITH SHUTDOWN AND ERROR OUTPUT

TC1054
TC1055
TC1186

ABSOLUTE MAXIMUM RATINGS*

| | |
|---|--------------------------------------|
| Input Voltage | 6.5V |
| Output Voltage | (- 0.3V) to (V _{IN} + 0.3V) |
| Power Dissipation | Internally Limited |
| Operating Temperature Range | - 40°C < T _J < 125°C |
| Storage Temperature | - 65°C to +150°C |
| Maximum Voltage on Any Pin | V _{IN} +0.3V to - 0.3V |
| Lead Temperature (Soldering, 10 Sec.) | +260°C |

*Stresses above those listed under "Absolute Maximum Ratings" may cause permanent damage to the device. These are stress ratings only and functional operation of the device at these or any other conditions above those indicated in the operation sections of the specifications is not implied. Exposure to Absolute Maximum Rating conditions for extended periods may affect device reliability.

ELECTRICAL CHARACTERISTICS: V_{IN} = V_{OUT} + 1V, I_L = 100 μA, C_L = 3.3 μF, $\overline{\text{SHDN}} > V_{IH}$, T_A = 25°C, unless otherwise noted.
Boldface type specifications apply for junction temperatures of - 40°C to +125°C.

| Symbol | Parameter | Test Conditions | Min | Typ | Max | Units |
|-------------------------------------|--|---|---------------------------------------|-----------------------------|--|--------|
| V _{IN} | Input Operating Voltage | | — | — | 6.0 | V |
| I _{OUTMAX} | Maximum Output Current | TC1054 TC1055 TC1186 | 50 100 150 | — — — | — — — | mA |
| V _{OUT} | Output Voltage | Note 1 | V_R - 2.5% | V _R ±0.5% | V_R + 2.5% | V |
| TC _{VOUT} | V _{OUT} Temperature Coefficient | Note 2 | — — | 20 40 | — — | ppm/°C |
| ΔV _{OUT} /ΔV _{IN} | Line Regulation | (V _R + 1V) ≤ V _{IN} ≤ 6V | — | 0.05 | 0.35 | % |
| ΔV _{OUT} /V _{OUT} | Load Regulation | TC1054; TC1055 TC1186 I _L = 0.1 mA to I _{OUTMAX} I _L = 0.1 mA to I _{OUTMAX} (Note 3) | — — — | 0.5 0.5 | 2 3 | % |
| V _{IN} - V _{OUT} | Dropout Voltage | I _L = 100 μA I _L = 20 mA I _L = 50 mA TC1055; TC1186 I _L = 100 mA TC1186 I _L = 150 mA (Note 4) | — — — — — | 2 65 85 180 270 | — — 120 250 400 | mV |
| I _{IN} | Supply Current | SHDN = V _{IH} , I _L = 0 | — | 50 | 80 | μA |
| I _{INSD} | Shutdown Supply Current | SHDN = 0V | — | 0.05 | 0.5 | μA |
| PSRR | Power Supply Rejection Ratio | F _{RE} ≤ 1 KHz | — | 64 | — | dB |
| I _{OUTSC} | Output Short Circuit Current | V _{OUT} = 0V | — | 300 | 450 | mA |
| ΔV _{OUT} /ΔP _D | Thermal Regulation | Notes 5, 6 | — | 0.04 | — | %/W |
| T _{SD} | Thermal Shutdown Die Temperature | | — | 160 | — | °C |
| ΔT _{SD} | Thermal Shutdown Hysteresis | | — | 10 | — | °C |
| eN | Output Noise | I _L = I _{OUTMAX} 470 pF from Bypass to GND | — | 260 | — | nV/√Hz |

SHDN Input

| Symbol | Parameter | Test Conditions | Min | Typ | Max | Units |
|-----------------|---------------------------|--------------------------------|-----|-----|-----|------------------|
| V _{IH} | SHDN Input High Threshold | V _{IN} = 2.5V to 6.5V | 45 | — | — | %V _{IN} |
| V _{IL} | SHDN Input Low Threshold | V _{IN} = 2.5V to 6.5V | — | — | 15 | %V _{IN} |

50mA, 100 mA, AND 150 mA CMOS LDOs WITH SHUTDOWN AND ERROR OUTPUT

TC1054
TC1055
TC1186

ELECTRICAL CHARACTERISTICS: $V_{IN} = V_{OUT} + 1V$, $I_L = 0.1\text{mA}$, $C_L = 3.3\mu\text{F}$, $\overline{\text{SHDN}} > V_{IH}$, $T_A = 25^\circ\text{C}$, unless otherwise noted. **BOLDFACE** type specifications apply for junction temperatures of -40°C to $+125^\circ\text{C}$.

| Symbol | Parameter | Test Conditions | Min | Typ | Max | Units |
|---------------------|------------------------------------|----------------------------|-----|-------------------|-----|-------|
| ERROR Output | | | | | | |
| V_{INMIN} | Minimum V_{IN} Operating Voltage | | 1.0 | — | — | V |
| V_{OL} | Output Logic Low Voltage | 1 mA Flows to ERROR | — | — | 400 | mV |
| V_{TH} | ERROR Threshold Voltage | See Figure 2 | — | $0.95 \times V_R$ | — | V |
| V_{HYS} | ERROR Positive Hysteresis | Note 7 | — | 50 | — | mV |

NOTES: 1. V_R is the regulator output voltage setting. For Example: $V_R = 2.5V, 2.7V, 2.85, 3.0V, 3.3V, 3.6V, 4.0V, 5.0V$.

2. $TC\ V_{OUT} = \frac{V_{OUTMAX} - V_{OUTMIN}}{V_{OUT} \times DT} \times 10^6$

3. Regulation is measured at a constant junction temperature using low duty cycle pulse testing. Load regulation is tested over a load range from 0.1 mA to the maximum specified output current. Changes in output voltage due to heating effects are covered by the thermal regulation specification.

4. Dropout voltage is defined as the input to output differential at which the output voltage drops 2% below its nominal value.

5. Thermal Regulation is defined as the change in output voltage at a time T after a change in power dissipation is applied, excluding load or line regulation effects. Specifications are for a current pulse equal to I_{LMAX} at $V_{IN} = 6V$ for $T = 10$ msec.

6. The maximum allowable power dissipation is a function of ambient temperature, the maximum allowable junction temperature and the thermal resistance from junction-to-air (i.e. T_A, T_J, q_{JA}). Exceeding the maximum allowable power dissipation causes the device to initiate thermal shutdown. Please see *Thermal Considerations* section of this data sheet for more details.

7. Hysteresis voltage is referenced by V_R .

5

PIN DESCRIPTION

| Pin No. (SOT-23A-5) | Symbol | Description |
|------------------------|--------------|---|
| 1 | V_{IN} | Unregulated supply input. |
| 2 | GND | Ground terminal. |
| 3 | SHDN | Shutdown control input. The regulator is fully enabled when a logic high is applied to this input. The regulator enters shutdown when a logic low is applied to this input. During shutdown, output voltage falls to zero, ERROR is open circuited and supply current is reduced to 0.5 μA (max). |
| 4 | ERROR | Out-of-Regulation Flag. (Open drain output). This output goes low when V_{OUT} is out-of-tolerance by approximately $\pm 5\%$. |
| 5 | V_{OUT} | Regulated voltage output. |

TC1054
TC1055
TC1186

DETAILED DESCRIPTION

The TC1054, TC1055, and TC1186 are precision fixed output voltage regulators. (If an adjustable version is desired, please see the TC1070, TC1071 or TC1187 data sheets.) Unlike bipolar regulators, the TC1054, TC1055, and TC1186 supply current does not increase with load current. In addition, V_{OUT} remains stable and within regulation at very low load currents (an important consideration in RTC and CMOS RAM battery back-up applications).

Figure 1 shows a typical application circuit. The regulator is enabled any time the shutdown input (\overline{SHDN}) is at or above V_{IH} , and shutdown (disabled) when \overline{SHDN} is at or below V_{IL} . \overline{SHDN} may be controlled by a CMOS logic gate, or I/O port of a microcontroller. If the \overline{SHDN} input is not required, it should be connected directly to the input supply. While in shutdown, supply current decreases to $0.05\mu A$ (typical), V_{OUT} falls to zero volts, and \overline{ERROR} is open-circuited.

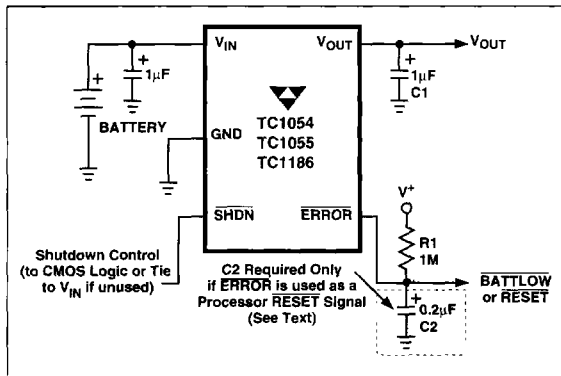

Figure 1. Typical Application Circuit

ERROR Open Drain Output

\overline{ERROR} is driven low whenever V_{OUT} falls out of regulation by more than -5% (typical). This condition may be caused by low input voltage, output current limiting, or thermal limiting. The \overline{ERROR} threshold is 5% below rated V_{OUT} regardless of the programmed output voltage value (e.g. $\overline{ERROR} = V_{OL}$ at 4.75V (typ.) for a 5.0V regulator and 2.85V (typ.) for a 3.0V regulator). \overline{ERROR} output operation is shown in Figure 2.

Note that \overline{ERROR} is active when V_{OUT} falls to V_{TH} , and inactive when V_{OUT} rises above V_{TH} by V_{HYS} .

As shown in Figure 1, \overline{ERROR} can be used as a battery low flag, or as a processor \overline{RESET} signal (with the addition of timing capacitor C2). $R1 \times C2$ should be chosen to maintain \overline{ERROR} below V_{IH} of the processor \overline{RESET} input for at least 200 msec to allow time for the system to stabilize.

Pull-up resistor R1 can be tied to V_{OUT} , V_{IN} or any other voltage less than $(V_{IN} + 0.3V)$.

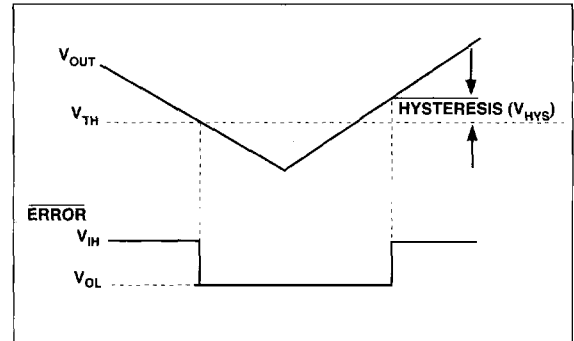

Figure 2. \overline{ERROR} Output Operation

Output Capacitor

A $1\mu F$ (min) capacitor from V_{OUT} to ground is recommended. The output capacitor should have an effective series resistance of 5Ω or less, and a resonant frequency above 1 MHz. A $1\mu F$ capacitor should be connected from V_{IN} to GND if there is more than 10 inches of wire between the regulator and the AC filter capacitor, or if a battery is used as the power source. Aluminum electrolytic or tantalum capacitor types can be used. (Since many aluminum electrolytic capacitors freeze at approximately $-30^\circ C$, solid tantalums are recommended for applications operating below $-25^\circ C$.) When operating from sources other than batteries, supply-noise rejection and transient response can be improved by increasing the value of the input and output capacitors and employing passive filtering techniques.

Thermal Considerations

Thermal Shutdown

Integrated thermal protection circuitry shuts the regulator off when die temperature exceeds $160^\circ C$. The regulator remains off until the die temperature drops to approximately $150^\circ C$.

Power Dissipation

The amount of power the regulator dissipates is primarily a function of input and output voltage, and output current. The following equation is used to calculate worst case actual power dissipation:

$$P_D = (V_{INMAX} - V_{OUTMIN}) I_{LOADMAX}$$

Where:

P_D = Worst case actual power dissipation

V_{INMAX} = Maximum voltage on V_{IN}

V_{OUTMIN} = Minimum regulator output voltage

$I_{LOADMAX}$ = Maximum output (load) current

Equation 1.

The maximum *allowable* power dissipation (Equation 2) is a function of the maximum ambient temperature (T_{AMAX}), the maximum allowable die temperature (125°C) and the thermal resistance from junction-to-air (θ_{JA}). SOT-23A-5 package has a θ_{JA} of approximately *220°C/Watt* when mounted on a single layer FR4 dielectric copper clad PC board.

$$P_{D MAX} = \frac{(T_{JMAX} - T_{AMAX})}{\theta_{JA}}$$

Where all terms are previously defined.

Equation 2.

Equation 1 can be used in conjunction with Equation 2 to ensure regulator thermal operation is within limits. For example:

Given:

$$V_{INMAX} = 3.0V \pm 5\%$$

$$V_{OUTMIN} = 2.7V - 2.5\%$$

$$I_{LOAD} = 40 \text{ mA}$$

$$T_{AMAX} = 55^\circ\text{C}$$

- Find: 1. Actual power dissipation
2. Maximum allowable dissipation

Actual power dissipation:

$$\begin{aligned} P_D &= (V_{INMAX} - V_{OUTMIN}) I_{LOADMAX} \\ &= [(3.0 \times 1.05) - (2.7 \times .975)] 40 \times 10^{-3} \\ &= 20.7 \text{ mW} \end{aligned}$$

Maximum allowable power dissipation:

$$\begin{aligned} P_{D MAX} &= \frac{(T_{JMAX} - T_{AMAX})}{\theta_{JA}} \\ &= \frac{(125 - 55)}{220} \\ &= 318 \text{ mW} \end{aligned}$$

In this example, the TC1054 dissipates a maximum of only 20.7 mW; far below the allowable limit of 318 mW. In a similar manner, Equation 1 and Equation 2 can be used to calculate maximum current and/or input voltage limits.

Layout Considerations

The primary path of heat conduction out of the package is via the package leads. Therefore, layouts having a ground plane, wide traces at the pads, and wide power supply bus lines combine to lower θ_{JA} and therefore increase the maximum allowable power dissipation limit.

50mA, 100 mA, AND 150 mA CMOS LDOs WITH SHUTDOWN AND ERROR OUTPUT

TC1054
TC1055
TC1186

TYPICAL CHARACTERISTICS: (Unless otherwise specified, all parts are measured at Temperature = 25°C)

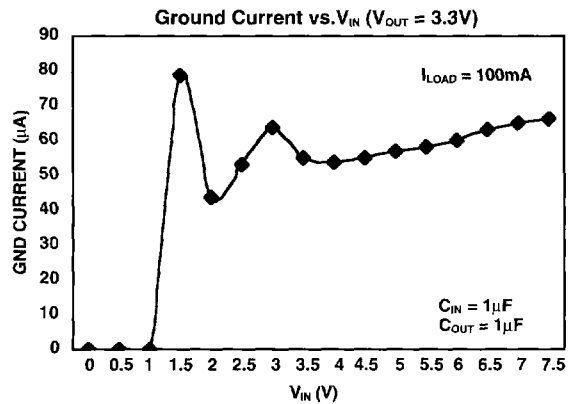
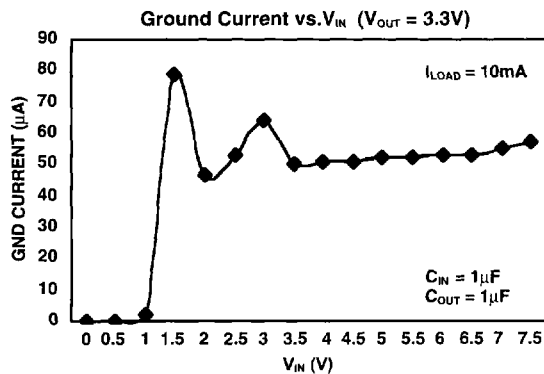
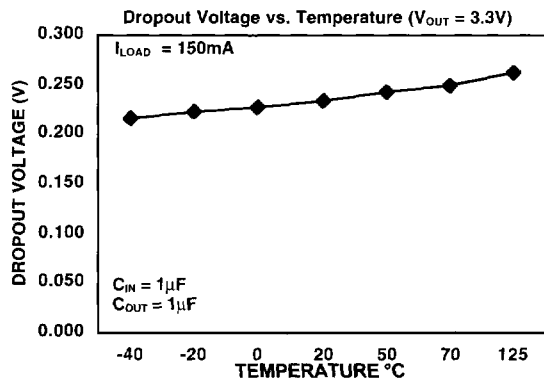
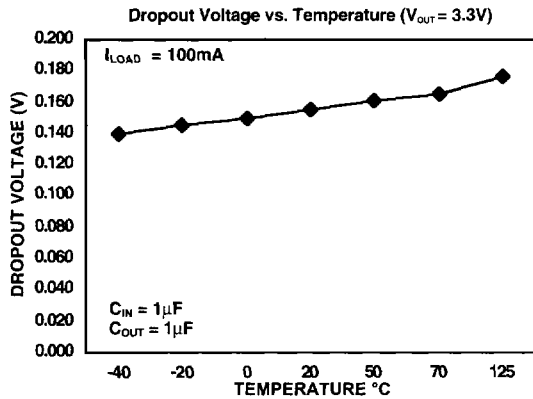
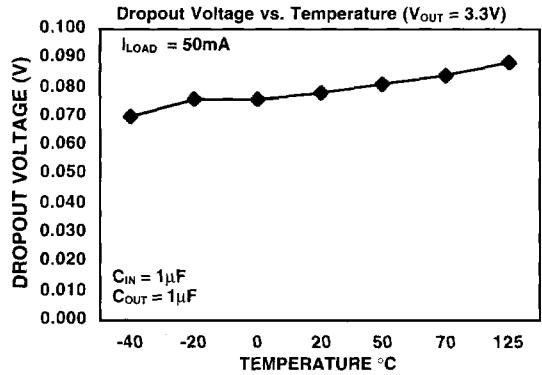
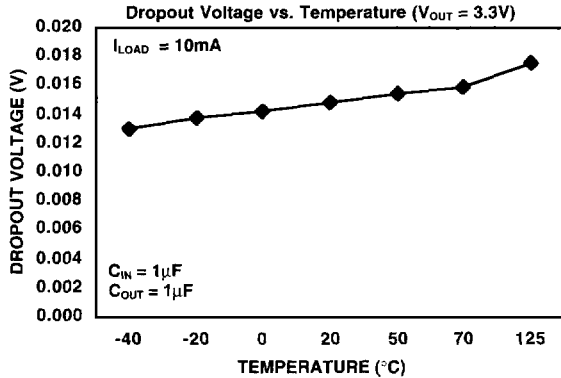

50mA, 100 mA, AND 150 mA CMOS LDOs WITH SHUTDOWN AND ERROR OUTPUT

TC1054
TC1055
TC1186

TYPICAL CHARACTERISTICS: (Unless otherwise specified, all parts are measured at Temperature = 25°C

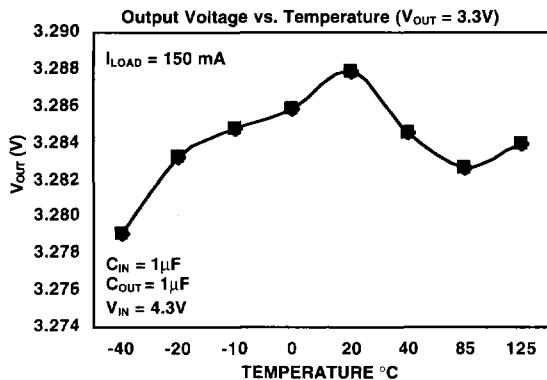
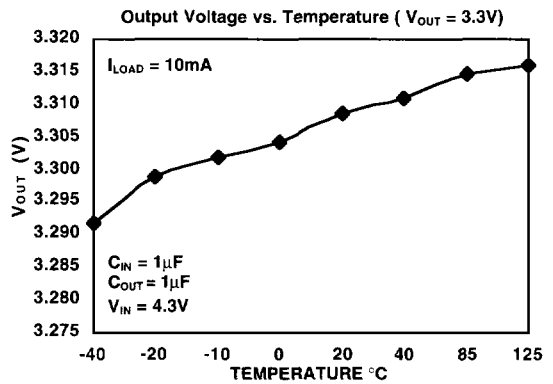
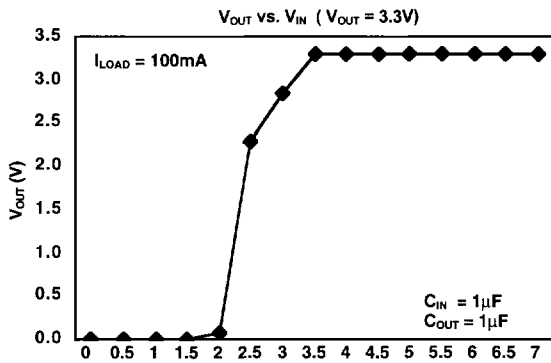
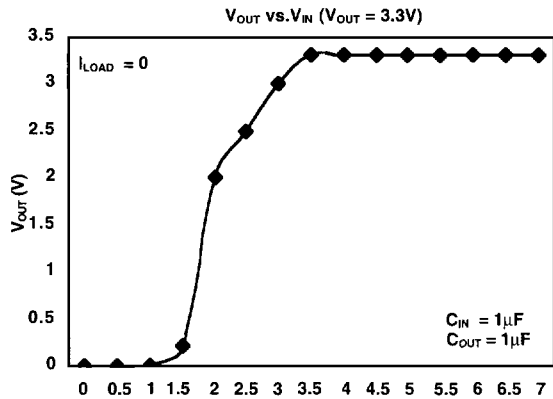
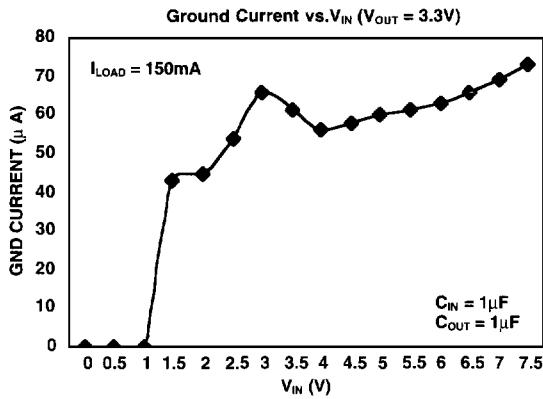

5

TC1054
TC1055
TC1186

TYPICAL CHARACTERISTICS

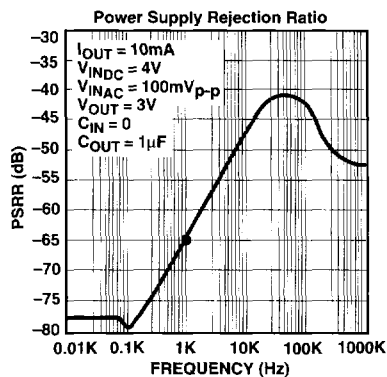
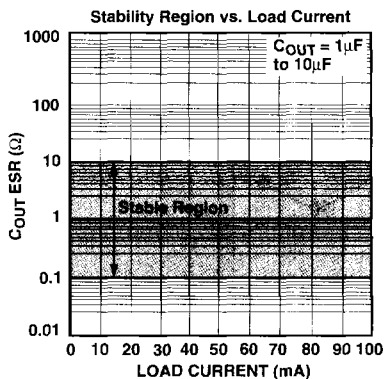
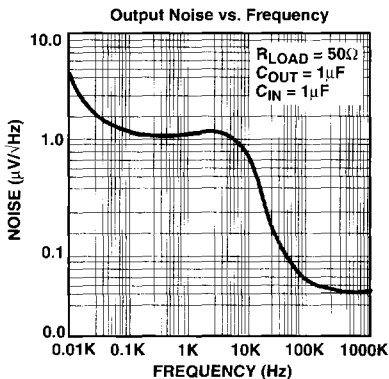
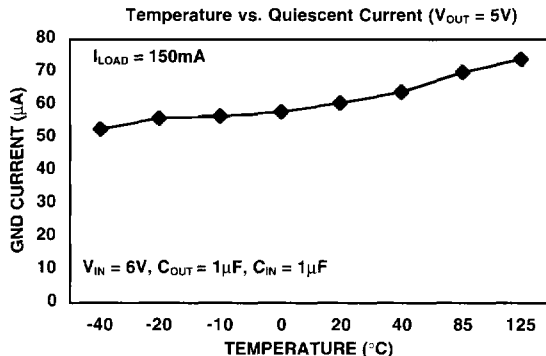
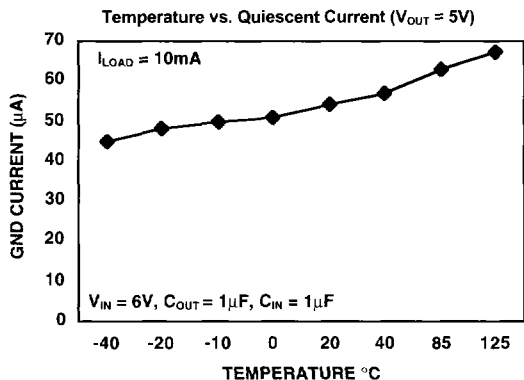
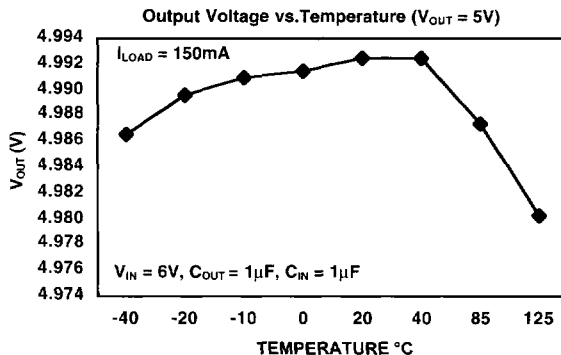
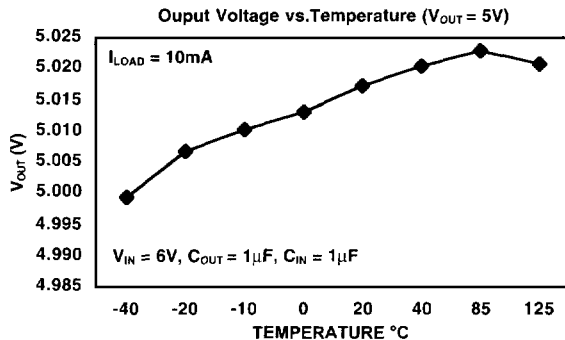

50mA, 100 mA, AND 150 mA CMOS LDOs WITH SHUTDOWN AND ERROR OUTPUT

TC1054
TC1055
TC1186

TYPICAL CHARACTERISTICS

Measure Rise Time of 3.3V LDO

Conditions: $C_{IN} = 1\mu\text{F}$, $C_{OUT} = 1\mu\text{F}$, $I_{LOAD} = 100\text{mA}$, $V_{IN} = 4.3\text{V}$,
Temp = 25°C, Rise Time = 184μS

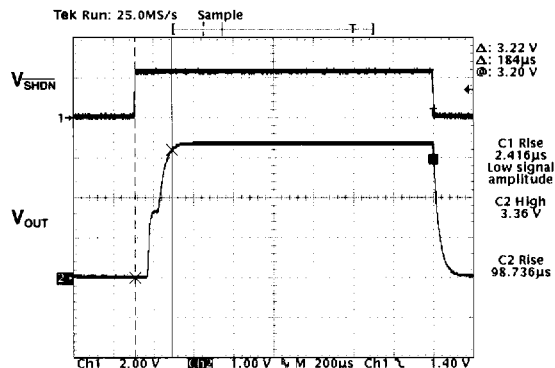

Measure Rise Time of 5.0V LDO

Conditions: $C_{IN} = 1\mu\text{F}$, $C_{OUT} = 1\mu\text{F}$, $I_{LOAD} = 100\text{mA}$, $V_{IN} = 6\text{V}$,
Temp = 25°C, Rise Time = 192μS

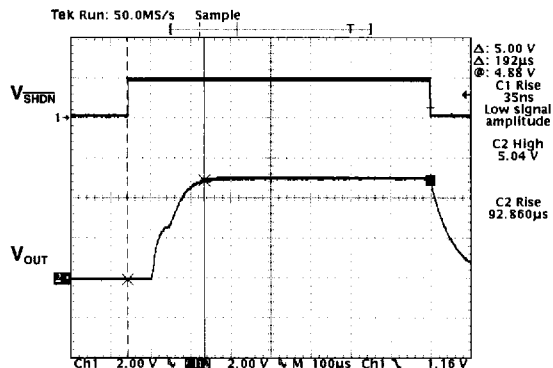

Measure Fall Time of 3.3V LDO

Conditions: $C_{IN} = 1\mu\text{F}$, $C_{OUT} = 1\mu\text{F}$, $I_{LOAD} = 100\text{mA}$, $V_{IN} = 4.3\text{V}$,
Temp = 25°C, Fall Time = 52μS

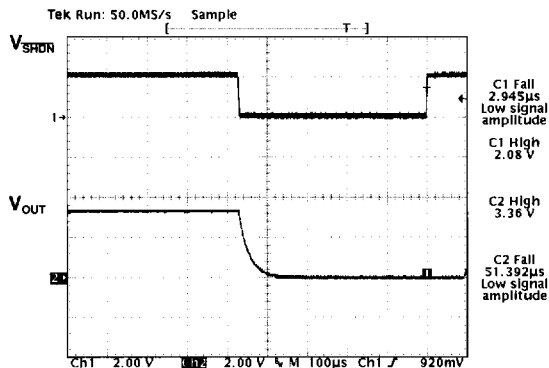

Measure Fall Time of 5.0V LDO

Conditions: $C_{IN} = 1\mu\text{F}$, $C_{OUT} = 1\mu\text{F}$, $I_{LOAD} = 100\text{mA}$, $V_{IN} = 6\text{V}$,
Temp = 25°C, Fall Time = 88μS

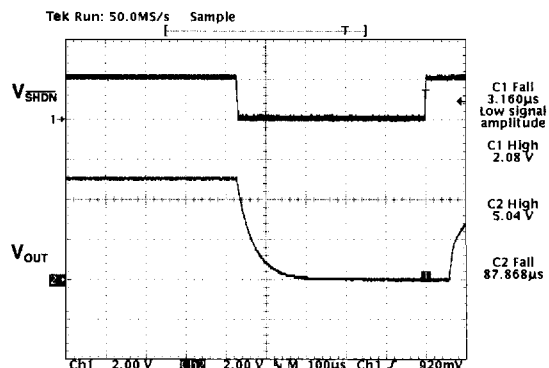

5

TC1054
TC1055
TC1186

TYPICAL CHARACTERISTICS

Thermal Shutdown Response of 5.0V LDO

Conditions: $V_{IN} = 6V, C_{IN} = 0\mu F, C_{OUT} = 1\mu F$

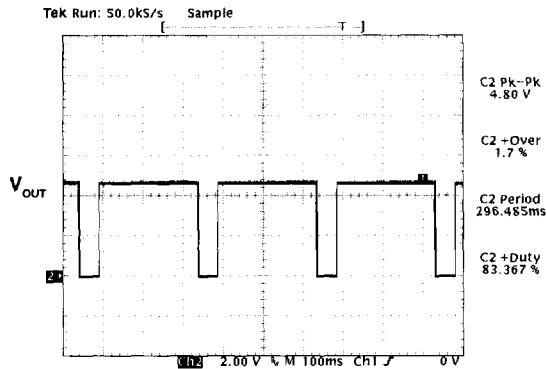

I_{LOAD} was increased until temperature of die reached about 160°C, at which time integrated thermal protection circuitry shuts the regulator off when die temperature exceeds approximately 160°C. The regulator remains off until die temperature drops to approximately 150°C.

MARKINGS

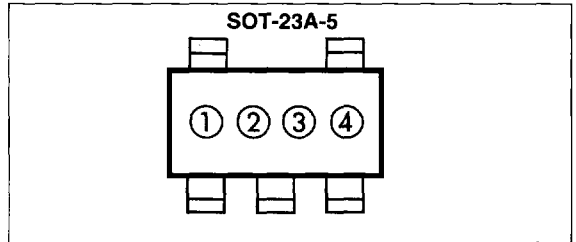

① & ② = part number code + temperature range and voltage

| (V) | TC1054 Code | TC1055 Code | TC1186 Code |
|------|-------------|-------------|-------------|
| 2.5 | C1 | D1 | P1 |
| 2.7 | C2 | D2 | P2 |
| 2.85 | C8 | D8 | P8 |
| 3.0 | C3 | D3 | P3 |
| 3.3 | C5 | D5 | P5 |
| 3.6 | C9 | D9 | P9 |
| 4.0 | C0 | D0 | P0 |
| 5.0 | C7 | D7 | P7 |

③ represents year and quarter code

④ represents lot ID number