



# 3.3V CMOS Static RAM 1 Meg (128K x 8-Bit) Revolutionary Pinout

IDT71V124

## Features

- ◆ 128K x 8 advanced high-speed CMOS static RAM
- ◆ JEDEC revolutionary pinout (center power/GND) for reduced noise
- ◆ Commercial (0°C to +70°C) and Industrial (-40°C to +85°C) temperature options
- ◆ Equal access and cycle times
  - Industrial and Commercial: 15/20ns
- ◆ One Chip Select plus one Output Enable pin
- ◆ Bidirectional inputs and outputs directly LVTTTL-compatible
- ◆ Low power consumption via chip deselect
- ◆ Available in 32-pin 400 mil Plastic SOJ.

## Description

The IDT71V124 is a 1,048,576-bit high-speed static RAM organized as 128K x 8. It is fabricated using IDT's high-performance, high-reliability CMOS technology. This state-of-the-art technology, combined with innovative circuit design techniques, provides a cost-effective solution for high-speed memory needs. The JEDEC center power/GND pinout reduces noise generation and improves system performance.

The IDT71V124 has an output enable pin which operates as fast as 7ns, with address access times as fast as 15ns available. All bidirectional inputs and outputs of the IDT71V124 are LVTTTL-compatible and operation is from a single 3.3V supply. Fully static asynchronous circuitry is used; no clocks or refreshes are required for operation.

The IDT71V124 is packaged in 32-pin 400 mil Plastic SOJ.

## Functional Block Diagram

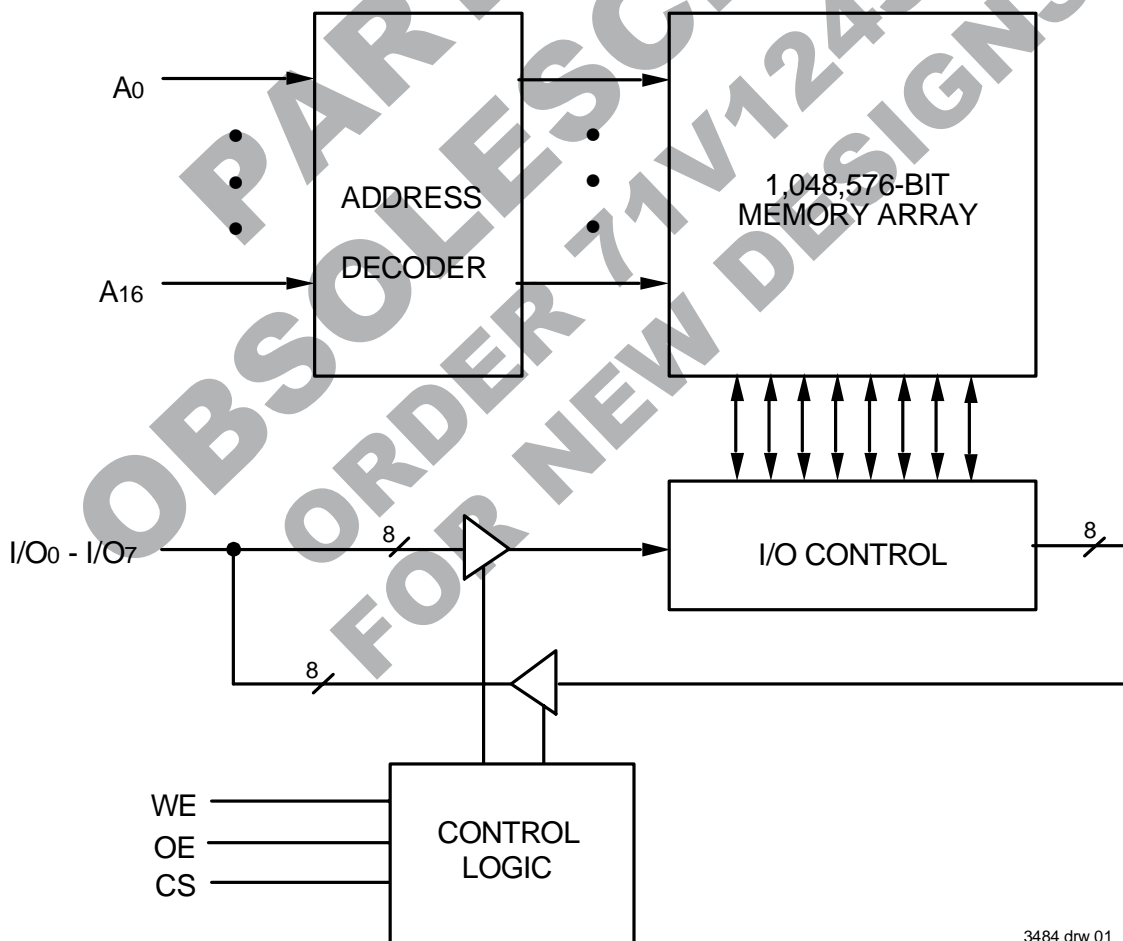

3484 drw 01

AUGUST 2000

## Pin Configuration

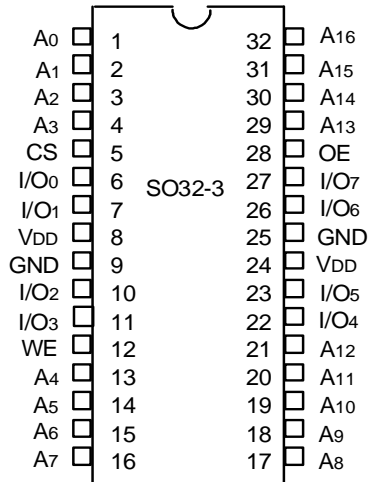

SOJ Top View  
3484 drw 02

## Absolute Maximum Ratings<sup>(1)</sup>

Symbol	Rating	Value	Unit
V <sub>TERM</sub> <sup>(2)</sup>	Terminal Voltage with Respect to GND	-0.5 to +4.1 <sup>(2)</sup>	V
T <sub>A</sub>	Operating Temperature	0 to +70	°C
T <sub>BIAS</sub>	Temperature Under Bias	-55 to +125	°C
T <sub>STG</sub>	Storage Temperature	-55 to +125	°C
P <sub>T</sub>	Power Dissipation	0.5	W
I <sub>OUT</sub>	DC Output Current	50	mA

3484 tbl 02

### NOTES:

- Stresses greater than those listed under ABSOLUTE MAXIMUM RATINGS may cause permanent damage to the device. This is a stress rating only and functional operation of the device at these or any other conditions above those indicated in the operational sections of this specification is not implied. Exposure to absolute maximum rating conditions for extended periods may affect reliability.
- V<sub>TERM</sub> must not exceed V<sub>DD</sub> + 0.5V.

## Truth Table<sup>(1,2)</sup>

CS	OE	WE	I/O	Function
L	L	H	DATA <sub>OUT</sub>	Read Data
L	X	L	DATA <sub>IN</sub>	Write Data
L	H	H	High-Z	Output Disabled
H	X	X	High-Z	Deselected – Standby (I <sub>SB</sub> )
V <sub>HC</sub> <sup>(3)</sup>	X	X	High-Z	Deselected – Standby (I <sub>SB</sub> )

3484 tbl 01

### NOTES:

- H = V<sub>IH</sub>, L = V<sub>IL</sub>, x = Don't care.
- V<sub>LC</sub> = 0.2V, V<sub>HC</sub> = V<sub>DD</sub> - 0.2V.
- Other inputs ≥ V<sub>HC</sub> or ≤ V<sub>LC</sub>.

## Capacitance

(T<sub>A</sub> = +25°C, f = 1.0MHz, SOJ package)

Symbol	Parameter <sup>(1)</sup>	Conditions	Max.	Unit
C <sub>IN</sub>	Input Capacitance	V <sub>IN</sub> = 3dV	8	pF
C <sub>VO</sub>	I/O Capacitance	V <sub>OUT</sub> = 3dV	8	pF

3484 tbl 03

### NOTE:

- This parameter is guaranteed by device characterization, but is not production tested.

## Recommended Operating Temperature and Supply Voltage

Grade	Temperature	GND	V <sub>DD</sub>
Commercial	0°C to +70°C	0V	See Below
Industrial	-40°C to +85°C	0V	See Below

3484 tbl 02a

## Recommended DC Operating Conditions

Symbol	Parameter	Min.	Typ.	Max.	Unit
V <sub>DD</sub>	Supply Voltage	3.0	3.3	3.6	V
GND	Ground	0	0	0	V
V <sub>IH</sub>	Input High Voltage	2.0	—	V <sub>DD</sub> + 0.3	V
V <sub>IL</sub>	Input Low Voltage	-0.3 <sup>(1)</sup>	—	0.8	V

3484 tbl 04

### NOTE:

- V<sub>IL</sub> (min.) = -1V for pulse width less than 5ns, once per cycle.

## DC Electrical Characteristics

(V<sub>DD</sub> = 3.3V ± 10%, Commercial and Industrial Temperature Ranges)

Symbol	Parameter	Test Condition	IDT71V124		Unit
			Min.	Max.	
I <sub>L</sub>	Input Leakage Current	V <sub>DD</sub> = Max., V <sub>IN</sub> = GND to V <sub>DD</sub>	—	5	μA
I <sub>LO</sub>	Output Leakage Current	V <sub>DD</sub> = Max., CS = V <sub>IH</sub> , V <sub>OUT</sub> = GND to V <sub>DD</sub>	—	5	μA
V <sub>OL</sub>	Output Low Voltage	I <sub>OL</sub> = 8mA, V <sub>DD</sub> = Min.	—	0.4	V
V <sub>OH</sub>	Output High Voltage	I <sub>OH</sub> = -8mA, V <sub>DD</sub> = Min.	2.4	—	V

3484 tbl 05

## DC Electrical Characteristics<sup>(1)</sup>

(V<sub>DD</sub> = 3.3V ± 10%, V<sub>LC</sub> = 0.2V, V<sub>HC</sub> = V<sub>DD</sub> - 0.2V)

Symbol	Parameter	71V124S15		71V124S20		Unit
		Com'l.	Ind.	Com'l.	Ind.	
I <sub>CC</sub>	Dynamic Operating Current $\overline{CS} \leq V_{IL}$ , Outputs Open, V <sub>DD</sub> = Max., f = f <sub>MAX</sub> <sup>(2)</sup>	100	120	95	115	mA
I <sub>SB</sub>	Standby Power Supply Current (TTL Level) $\overline{CS} \geq V_{IH}$ , Outputs Open, V <sub>DD</sub> = Max., f = f <sub>MAX</sub> <sup>(2)</sup>	35	40	30	35	mA
I <sub>SB1</sub>	Full Standby Power Supply Current (CMOS Level) $\overline{CS} \geq V_{HC}$ , Outputs Open, V <sub>DD</sub> = Max., f = 0 <sup>(2)</sup> V <sub>IN</sub> ≤ V <sub>LC</sub> or V <sub>IN</sub> ≥ V <sub>HC</sub>	5	7	5	7	mA

3484 tbl 06

### NOTES:

- All values are maximum guaranteed values.
- f<sub>MAX</sub> = 1/trc (all address inputs are cycling at f<sub>MAX</sub>); f = 0 means no address input lines are changing.

## AC Test Conditions

Input Pulse Levels	GND to 3.0V
Input Rise/Fall Times	3ns
Input Timing Reference Levels	1.5V
Output Reference Levels	1.5V
AC Test Load	See Figure 1 and 2

3484 tbl 07

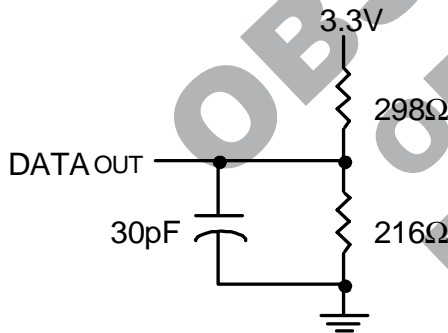

3484 drw 03

Figure 1. AC Test Load

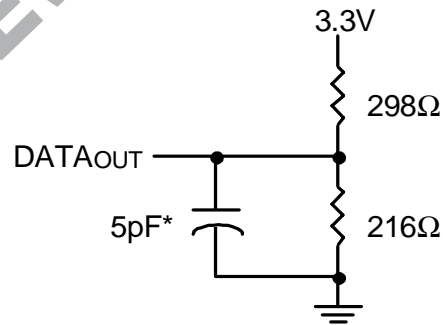

3484 drw 04

\*Including jig and scope capacitance.

Figure 2. AC Test Load  
(for t<sub>CLZ</sub>, t<sub>OLZ</sub>, t<sub>CHZ</sub>, t<sub>OHZ</sub>, t<sub>OW</sub>, and t<sub>WHZ</sub>)

**AC Electrical Characteristics** ( $V_{DD} = 3.3V \pm 10\%$ , Commercial and Industrial Ranges)

Symbol	Parameter	71V124S15		71V124S20		Unit
		Min.	Max.	Min.	Max.	
<b>READ CYCLE</b>						
t <sub>RC</sub>	Read Cycle Time	15	—	20	—	ns
t <sub>AA</sub>	Address Access Time	—	15	—	20	ns
t <sub>ACS</sub>	Chip Select Access Time	—	15	—	20	ns
t <sub>CLZ</sub> <sup>(1)</sup>	Chip Select to Output in Low-Z	3	—	3	—	ns
t <sub>CHZ</sub> <sup>(1)</sup>	Chip Deselect to Output in High-Z	0	7	0	8	ns
t <sub>OE</sub>	Output Enable to Output Valid	—	7	—	8	ns
t <sub>OLZ</sub> <sup>(1)</sup>	Output Enable to Output in Low-Z	0	—	0	—	ns
t <sub>OHZ</sub> <sup>(1)</sup>	Output Disable to Output in High-Z	0	5	0	7	ns
t <sub>OH</sub>	Output Hold from Address Change	4	—	4	—	ns
t <sub>PU</sub> <sup>(1)</sup>	Chip Select to Power-Up Time	0	—	0	—	ns
t <sub>PD</sub> <sup>(1)</sup>	Chip Deselect to Power-Down Time	—	15	—	20	ns
<b>WRITE CYCLE</b>						
t <sub>WC</sub>	Write Cycle Time	15	—	20	—	ns
t <sub>AW</sub>	Address Valid to End of Write	12	—	15	—	ns
t <sub>CW</sub>	Chip Select to End of Write	12	—	15	—	ns
t <sub>AS</sub>	Address Set-up Time	0	—	0	—	ns
t <sub>WP</sub>	Write Pulse Width	12	—	15	—	ns
t <sub>WR</sub>	Write Recovery Time	0	—	0	—	ns
t <sub>DW</sub>	Data Valid to End of Write	8	—	9	—	ns
t <sub>DH</sub>	Data Hold Time	0	—	0	—	ns
t <sub>OW</sub> <sup>(1)</sup>	Output Active from End of Write	3	—	4	—	ns
t <sub>WHZ</sub> <sup>(1)</sup>	Write Enable to Output in High-Z	0	5	0	8	ns

3484 tbl 08

**NOTE:**

1. This parameter guaranteed with the AC load (Figure 2) by device characterization, but is not production tested.

### Timing Waveform of Read Cycle No. 1<sup>(1)</sup>

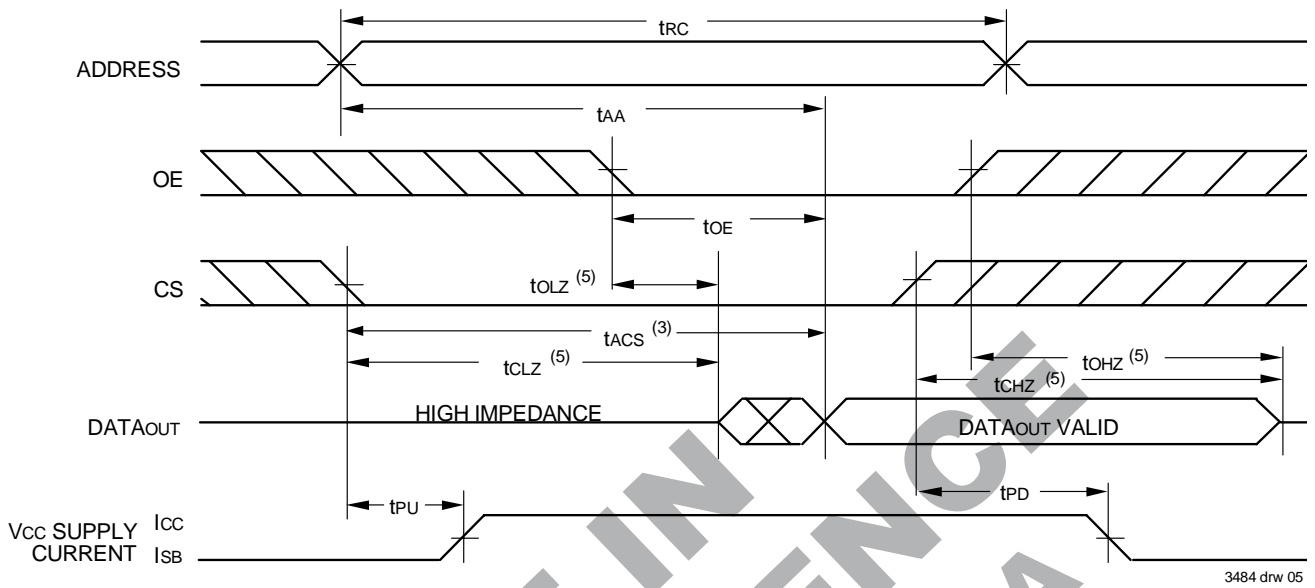

### Timing Waveform of Read Cycle No. 2<sup>(1,2,4)</sup>

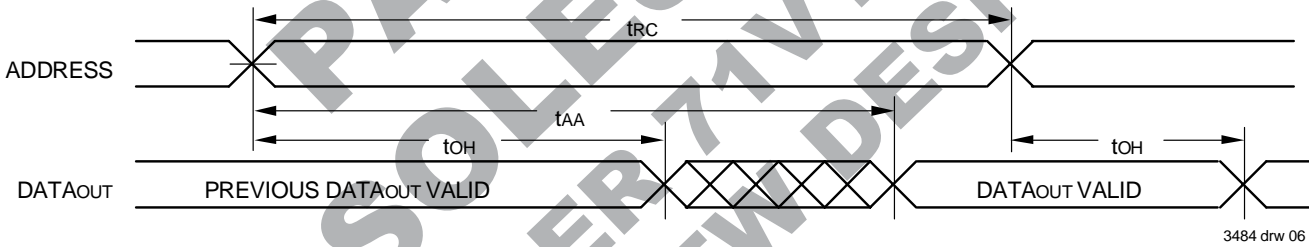

**NOTES:**

1.  $\overline{WE}$  is HIGH for Read Cycle.
2. Device is continuously selected,  $\overline{CS}$  is LOW.
3. Address must be valid prior to or coincident with the later of  $\overline{CS}$  transition LOW; otherwise  $t_{AA}$  is the limiting parameter.
4.  $\overline{OE}$  is LOW.
5. Transition is measured  $\pm 200mV$  from steady state.

### Timing Waveform of Write Cycle No.1 ( $\overline{WE}$ Controlled Timing)<sup>(1,2,4)</sup>

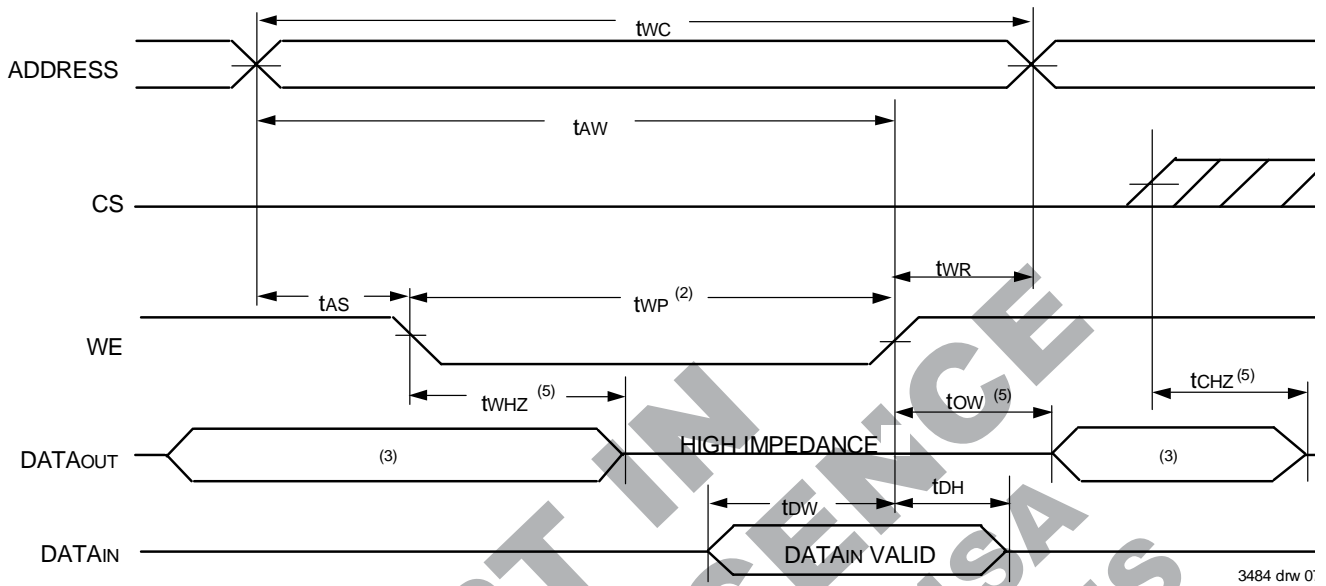

### Timing Waveform of Write Cycle No. 2 ( $\overline{CS}$ Controlled Timing)<sup>(1,4)</sup>

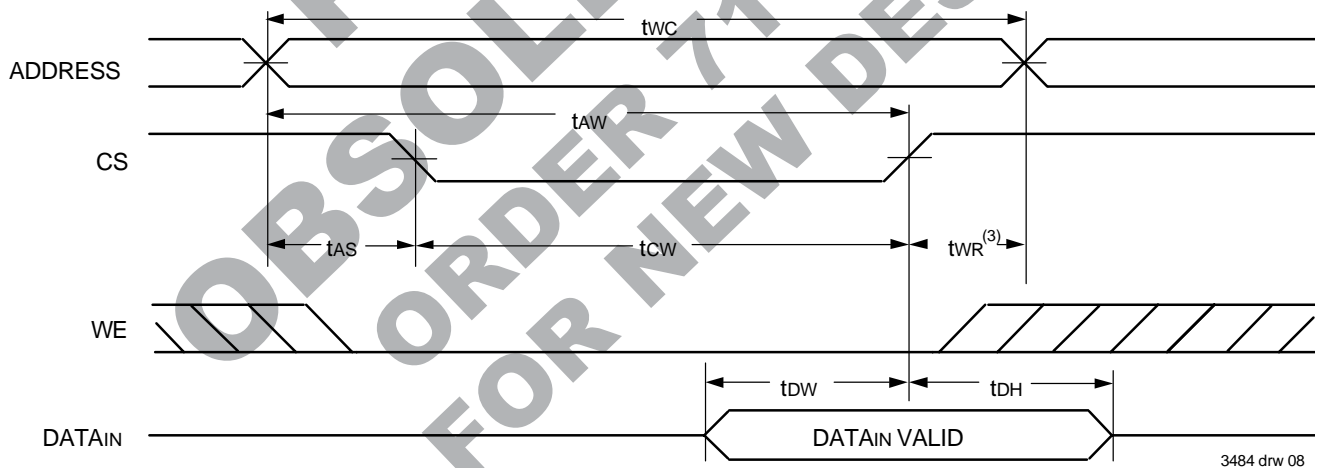

**NOTES:**

1. A write occurs during the overlap of a LOW  $\overline{CS}$  and a LOW  $\overline{WE}$ .
2.  $\overline{OE}$  is continuously HIGH. During a  $\overline{WE}$  controlled write cycle with  $\overline{OE}$  LOW,  $tWP$  must be greater than or equal to  $tWHZ + tDW$  to allow the I/O drivers to turn off and data to be placed on the bus for the required  $tOW$ . If  $\overline{OE}$  is HIGH during a  $\overline{WE}$  controlled write cycle, this requirement does not apply and the minimum write pulse is the specified  $tWP$ .
3. During this period, I/O pins are in the output state, and input signals must not be applied.
4. If the  $\overline{CS}$  LOW transition occurs simultaneously with or after the  $\overline{WE}$  LOW transition, the outputs remain in a high impedance state.  $\overline{CS}$  must be active during the  $tCW$  write period.
5. Transition is measured  $\pm 200mV$  from steady state.

### Ordering Information

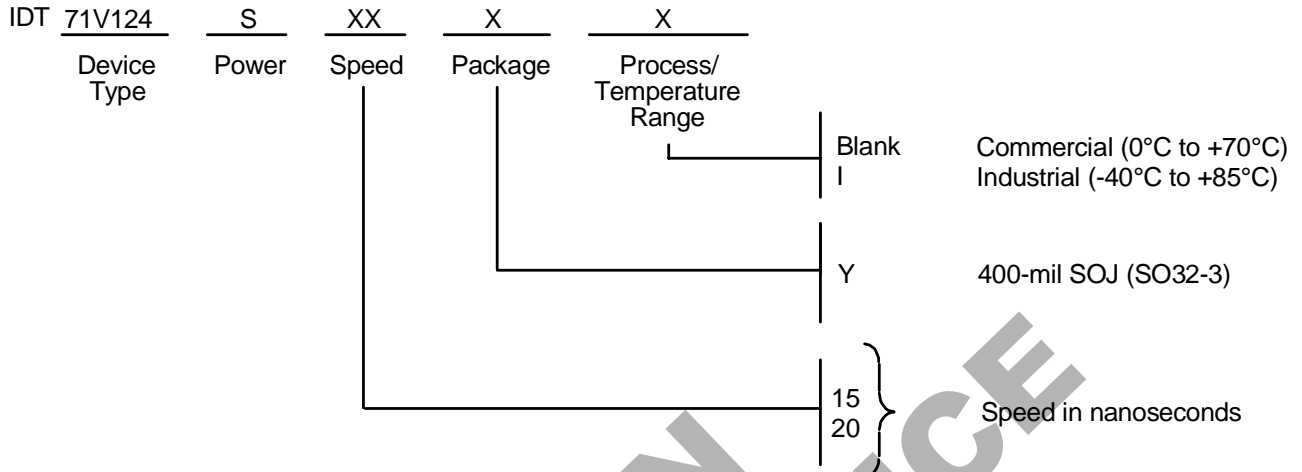

3484 drw 09

**PART IN  
OBSOLESCENCE  
ORDER 71V124SA  
FOR NEW DESIGNS**

## Datasheet Document History

11/1/99		Updated to new format
	Pg. 2	Expressed commercial and industrial temperature ranges on DC Electrical table
	Pg. 2	Added Recommended Operating Temperature and Supply Voltage table
	Pg. 4	Expressed commercial and industrial ranges on AC Electrical table
	Pg. 4	Revised footnotes and notes on AC Electrical table
	Pg. 6	Revised footnotes on Write Cycle No. 1 diagram
	Pg. 8	Added datasheet document history
08/30/00		Part in obsolescence; order part 71V124SA. See PDN# S-0004

**PART IN  
OBsolescence  
ORDER 71V124SA  
FOR NEW DESIGNS**



**CORPORATE HEADQUARTERS**  
6024 Silver Creek Valley Road  
San Jose, CA 95138

**for SALES:**  
800-345-7015 or  
408-284-8200  
fax: 408-284-2775  
[www.idt.com](http://www.idt.com)

**for Tech Support:**  
[ipchelp@idt.com](mailto:ipchelp@idt.com)  
800-345-7015

The IDT logo is a registered trademark of Integrated Device Technology, Inc.