



PIN GRID ARRAY SOCKETS

Standard, Long Solder Tail & Low Profile

Series 510, 511, 515

- Series 510, 511, & 515 PGA sockets are available in three solder tail lengths: standard, long and low profile.
- Choice of three low force clips to cover all applications.
- Hi-Temp PCT polyester insulator suitable for all forms of soldering.

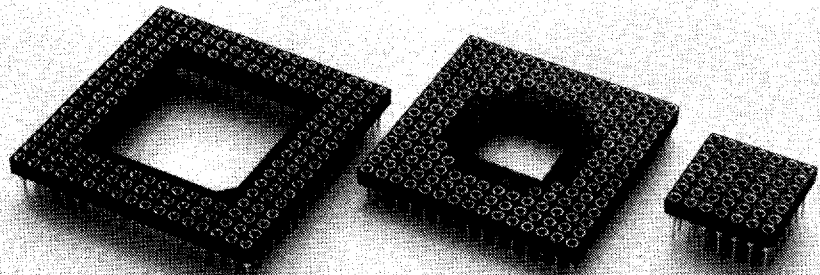

STANDARD SOLDER TAIL SERIES 510

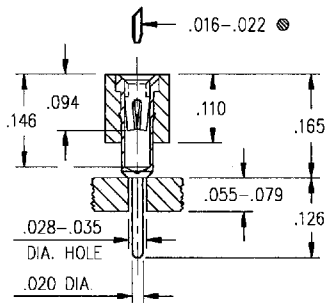

PLATING OPTIONS: 13,91,93,97,99

LONG SOLDER TAIL SERIES 511

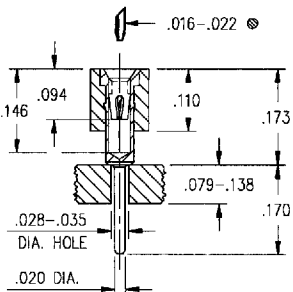

PLATING OPTIONS: 13,93

LOW PROFILE PIN SERIES 515

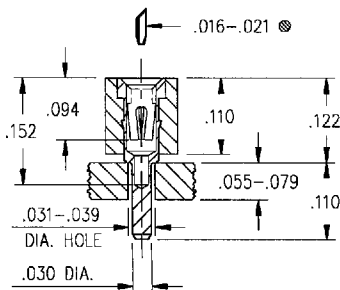

PLATING OPTIONS: 13,93

Ordering Information

1. Select pin type for PGA socket at left (standard, long or low profile) to determine series number.
2. Specify 2-digit plating code from chart at bottom of page (Note plating options available for each series under illustrations at left)
3. Locate footprint pattern from pages 44 to 48, the middle 8 digits of the part number will be located under the pattern.
4. Determine the last 2 digits of part number from the Contact Chart below.

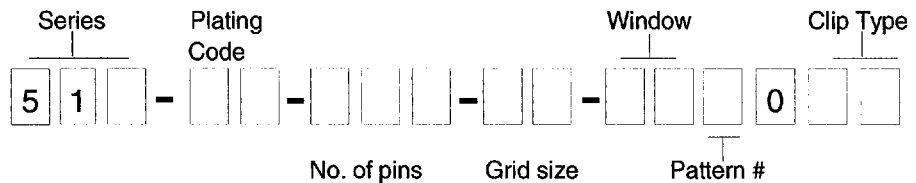

Determined from footprint pattern pages 44 to 48

EXAMPLE OF COMPLETE PART NUMBER :

510-93-068-11-061001

This is a 68 pin (11x11 grid) insulator with a .6" square window and fitted with standard solder tail socket pins. Pins are tin plated, inner contacts are Mill-Max # 32 and are plated 30 μ" gold.

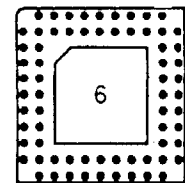

Clip Type

Contact (Clip) Chart

01	Mill-Max #32 clip, standard low force, recommended for devices with less than 150 pins. See page 151 for details.
02	Mill-Max #35 clip, ultra low force, recommended for devices with more than 150 pins, but less than 250 pins. See page 151 for details.
03	Mill-Max #43 clip, "ultra lite", recommended for devices with more than 250 pins. See page 151 for details.

SPECIFY PLATING CODE XX =	13	91	93	97	99
Sleeve (Pin)	10 μ" Au	200 μ" Sn	200 μ" Sn	200 μ" Sn	200 μ" Sn
Contact (Clip)	30 μ" Au	10 μ" Au	30 μ" Au	Au Flash	200 μ" Sn

32 CONTACT

FOR .015 - .026 DIAMETER PINS ($\delta = .009$)
6-FINGER • GROUP C

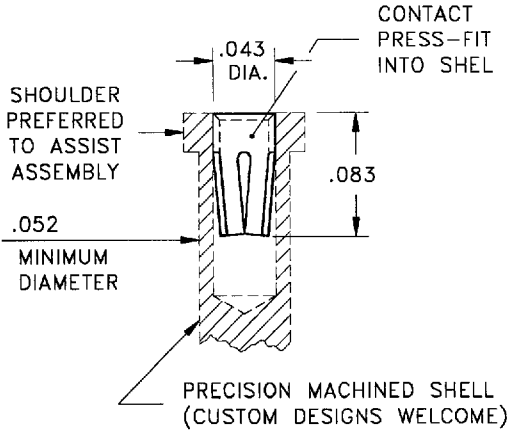

CONTACT MATERIAL:
BERYLLIUM COPPER Alloy 172, Heat treated

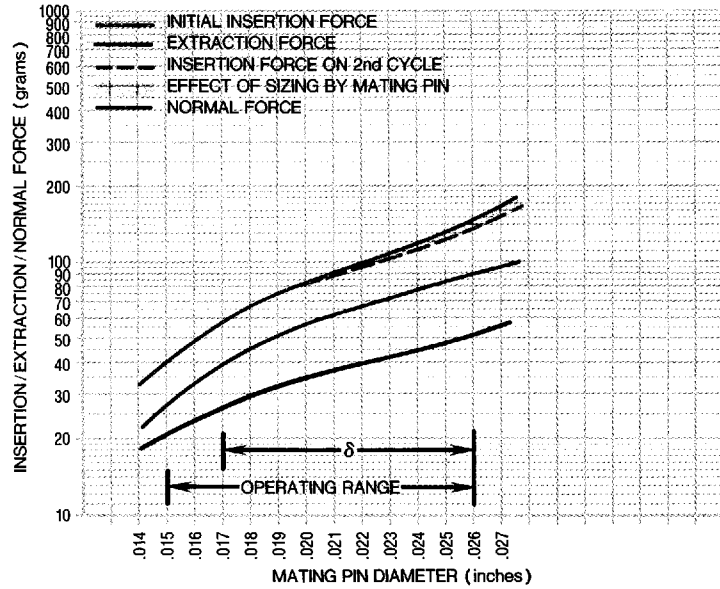

35 CONTACT

FOR .015 - .026 DIAMETER PINS ($\delta = .008$)
6-FINGER • GROUP C

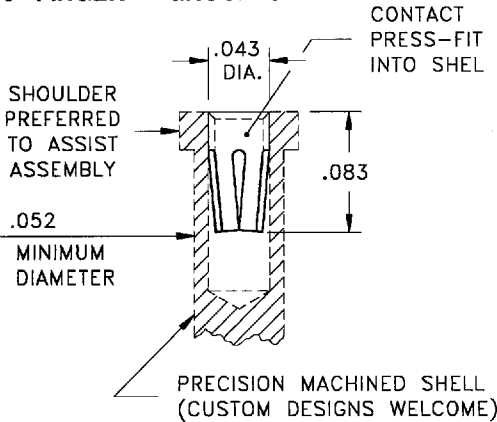

CONTACT MATERIAL:
BERYLLIUM COPPER Alloy 172, Heat treated

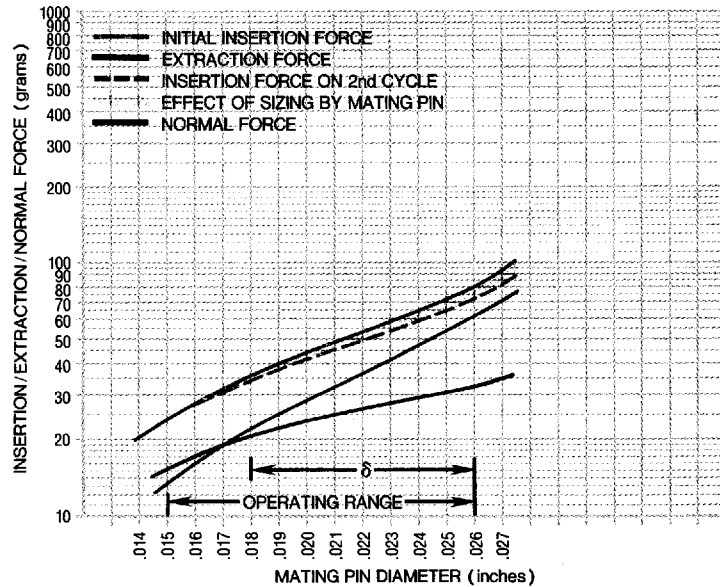

43 CONTACT

FOR .015 - .026 DIAMETER PINS ($\delta = .008$)
6-FINGER • GROUP C

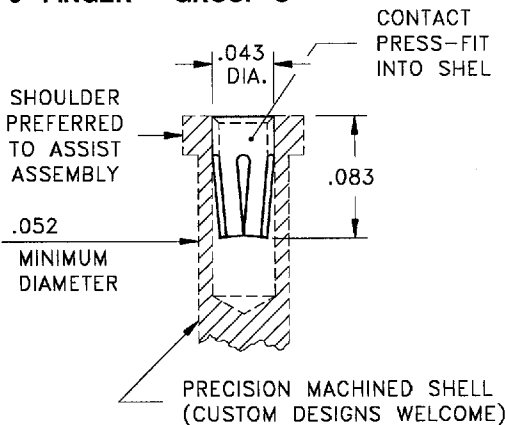

CONTACT MATERIAL:
BERYLLIUM COPPER Alloy 172, Heat treated

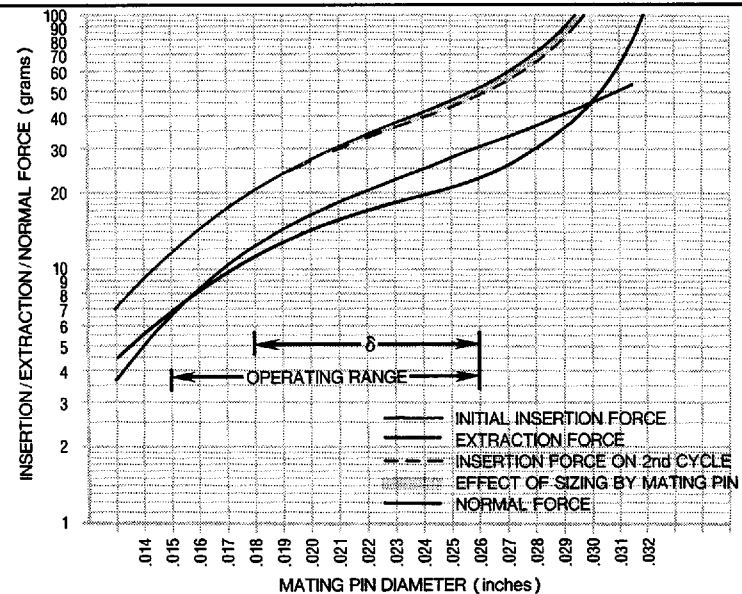



PIN GRID ARRAY SOCKETS Footprints

5 X 5	5 X 5	5 X 5		6 X 6	6 X 6
XXX-XX-012-05-001	XXX-XX-022-05-001	XXX-XX-025-05-000		XXX-XX-028-06-005	XXX-XX-036-06-000
					TOP VIEW
7 X 7		8 X 8	8 X 8	8 X 8	
XXX-XX-049-07-000		XXX-XX-044-08-031	XXX-XX-045-08-005	XXX-XX-064-08-000	
9 X 9	9 X 9	9 X 9	9 X 9	9 X 9	
XXX-XX-032-09-041	XXX-XX-052-09-045	XXX-XX-056-09-041	XXX-XX-072-09-001	XXX-XX-081-09-000	
10 X 10	10 X 10	10 X 10	10 X 10	10 X 10	10 X 10
XXX-XX-064-10-051	XXX-XX-065-10-051	XXX-XX-068-10-041	XXX-XX-084-10-031	XXX-XX-085-10-031	XXX-XX-100-10-000
11 X 11	11 X 11	11 X 11	11 X 11	11 X 11	11 X 11
XXX-XX-059-11-001	XXX-XX-068-11-061	XXX-XX-069-11-061	XXX-XX-072-11-042	XXX-XX-072-11-061	XXX-XX-073-11-042
11 X 11	11 X 11	11 X 11	11 X 11	11 X 11	11 X 11
XXX-XX-073-11-061	XXX-XX-076-11-041	XXX-XX-084-11-041	XXX-XX-084-11-045	XXX-XX-085-11-041	XXX-XX-092-11-041



PIN GRID ARRAY SOCKETS Footprints

11 X 11	11 X 11	11 X 11			
XXX-XX-096-11-041	XXX-XX-097-11-041	XXX-XX-121-11-000			

12 X 12	12 X 12	12 X 12	12 X 12	12 X 12	12 X 12
XXX-XX-081-12-071	XXX-XX-084-12-051	XXX-XX-088-12-052	XXX-XX-089-12-051	XXX-XX-108-12-051	XXX-XX-109-12-051

					TOP VIEW
12 X 12					
XXX-XX-144-12-000					

13 X 13	13 X 13	13 X 13	13 X 13	13 X 13	13 X 13
XXX-XX-084-13-081	XXX-XX-085-13-042	XXX-XX-085-13-081	XXX-XX-088-13-062	XXX-XX-088-13-081	XXX-XX-089-13-061

13 X 13	13 X 13	13 X 13	13 X 13	13 X 13	13 X 13
XXX-XX-089-13-082	XXX-XX-098-13-061	XXX-XX-100-13-061	XXX-XX-100-13-062	XXX-XX-101-13-061	XXX-XX-114-13-061

13 X 13	13 X 13	13 X 13	13 X 13	13 X 13	13 X 13
XXX-XX-114-13-062	XXX-XX-120-13-061	XXX-XX-121-13-061	XXX-XX-124-13-041	XXX-XX-125-13-041	XXX-XX-128-13-041



PIN GRID ARRAY SOCKETS Footprints

13 X 13	13 X 13	13 X 13	13 X 13	13 X 13	13 X 13
XXX-XX-132-13-041	XXX-XX-133-13-045	XXX-XX-144-13-041	XXX-XX-145-13-041	XXX-XX-154-13-021	XXX-XX-169-13-000
14 X 14	14 X 14	14 X 14	14 X 14	14 X 14	14 X 14
XXX-XX-124-14-071	XXX-XX-125-14-071	XXX-XX-132-14-071	XXX-XX-133-14-071	XXX-XX-135-14-051	XXX-XX-136-14-051
					TOP VIEW
14 X 14	14 X 14				
XXX-XX-181-14-031	XXX-XX-196-14-000				
15 X 15	15 X 15	15 X 15	15 X 15	15 X 15	15 X 15
XXX-XX-114-15-063	XXX-XX-121-15-061	XXX-XX-142-15-085	XXX-XX-144-15-082	XXX-XX-145-15-002	XXX-XX-145-15-081
15 X 15	15 X 15	15 X 15	15 X 15	15 X 15	15 X 15
XXX-XX-149-15-061	XXX-XX-149-15-063	XXX-XX-153-15-061	XXX-XX-156-15-061	XXX-XX-161-15-005	XXX-XX-176-15-061
15 X 15	15 X 15	15 X 15	15 X 15		
XXX-XX-177-15-061	XXX-XX-179-15-041	XXX-XX-181-15-041	XXX-XX-225-15-000		



PIN GRID ARRAY SOCKETS Footprints

16 X 16	16 X 16	16 X 16	16 X 16	16 X 16	16 X 16
XXX-XX-155-16-003	XXX-XX-159-16-105	XXX-XX-173-16-005	XXX-XX-175-16-005	XXX-XX-175-16-006	XXX-XX-256-16-000

17 X 17	17 X 17	17 X 17	17 X 17	17 X 17	17 X 17
XXX-XX-145-17-001	XXX-XX-168-17-101	XXX-XX-168-17-105	XXX-XX-169-17-101	XXX-XX-181-17-001	XXX-XX-209-17-081

					TOP VIEW
17 X 17	17 X 17	17 X 17			
XXX-XX-240-17-061	XXX-XX-289-17-000	XXX-XX-325-17-105			

18 X 18	18 X 18	18 X 18	18 X 18	18 X 18	18 X 18
XXX-XX-155-18-121	XXX-XX-179-18-095	XXX-XX-179-18-117	XXX-XX-223-18-095	XXX-XX-223-18-098	XXX-XX-224-18-095

18 X 18	18 X 18	18 X 18	18 X 18		
XXX-XX-225-18-091	XXX-XX-241-18-075	XXX-XX-324-18-000	XXX-XX-391-18-096		

19 X 19	19 X 19	19 X 19	19 X 19	19 X 19	19 X 19
XXX-XX-238-19-086	XXX-XX-256-19-081	XXX-XX-281-19-081	XXX-XX-296-19-125	XXX-XX-296-19-126	XXX-XX-296-19-127





PIN GRID ARRAY SOCKETS Footprints

19 X 19	19 X 19	19 X 19			
XXX-XX-296-19-128	XXX-XX-320-19-126	XXX-XX-361-19-000			
20 X 20	20 X 20	20 X 20			
XXX-XX-299-20-096	XXX-XX-400-20-000	XXX-XX-447-20-115			
					TOP VIEW
21 X 21	21 X 21	21 X 21	21 X 21		
XXX-XX-273-21-125	XXX-XX-273-21-126	XXX-XX-323-21-005	XXX-XX-441-21-000		
22 X 22	22 X 22				
XXX-XX-383-22-105	XXX-XX-499-22-136				
24 X 24					4 X 8
XXX-XX-431-24-125					XXX-XX-032-01-503

Notes:

The PGA pinouts illustrated on pages 44 thru 48 are only the most frequently used ones. Many other configurations have already been produced in small quantities. Please ask for details.

Please note that all drawings are top views of the PGA Sockets.



GENERAL TECHNICAL SPECIFICATIONS

MATERIALS

- Insulator body:

Standard material is glass filled thermoplastic polyester (PBT), self-extinguishing, rated UL94V-0. Heat deflection temperature (HDT @ 264 psi) = 204° C (400° F) Color black. Resistant to detergents, mineral acids, solvents, greases and oils (short time).

Surface mount and pin grid array socket insulators are molded from high temperature PCT polyester. HDT @ 264 psi = 254° C (490° F). This material is suitable for all forms of soldering including infra-red reflow and vapor-phase.

Products using standard open frame DIP insulators may also be ordered with high temperature PCT polyester, see ordering information on page 72.

Preci-Dip Series 110,510 and 800 are recognized under the Component Program of Underwriters Laboratories Inc., File E 135165.



- Receptacle (sleeve):

Screw-machined brass (QQ-B-626), plated 10µ" gold or 200µ" tin-lead (SnPb 90/10) over 80-120µ" nickel.

- Pin:

Screw-machined brass (QQ-B-626), plated 10µ" gold or 200µ" tin-lead (SnPb 90/10) over 80-120µ" nickel.

- Contact (Clip):

Stamped beryllium-copper (QQ-C-533) heat treated, plated gold flash, 10µ" or 30µ" gold, or 200µ" tin-lead (SnPb 90/10) over 80-120µ" nickel.

	4-finger standard M-M #30	4-finger standard M-M #12	3-finger M-M #11	6-finger low force M-M #32	6-finger ultra-low M-M #35	6-finger ultra-lite M-M #43
insertion force typical values	150 gm	300 gm	60 gm	60 gm	30 gm	15 gm
extraction force typical values	75 gm	150 gm	30 gm	30 gm	15 gm	8 gm

- Mechanical life: 100 cycles min.

ELECTRICAL DATA

- Rated current: 1A
- Rated voltage: 100 VRMS/150 VDC
- Contact resistance: 10 mΩ max.
- Insulation resistance: 10,000 MΩ min.
- Dielectric strength: 1000 VRMS (Min 700 VRMS for series 117 ShrinkDip)
- Air and creepage distance: .024" min. (.012 for series 117 ShrinkDip)
- Capacitance: 0.3 pF max.

ENVIRONMENTAL DATA

- Operating temperature range: -55/+125°C
- Vibration (No electrical discontinuity greater than 1µs): 10-2000 Hz, 15 g
- Shock (No electrical discontinuity greater than 1µs): 150 g
- Solderability: IEC 68-2-20 Ta
- Resistance to soldering heat: IEC 68-2-20, 260°C, 5s
- Resistance to atmospheric corrosion: IEC 68-2-42 and 43
- Climatic category (IEC): 55/125/21

TECHNICAL SPECIFICATIONS FOR PLCC SOCKETS

MATERIALS:

- Insulator: Glass filled thermoplastic, self-extinguishing rated, UL94V-0, color black.
- Contact: Plated copper alloy overall nickel underplating. finish: (active contact area) tin/lead . (termination area) tin/lead.

MECHANICAL DATA:

- Contact pressure (per contact): 150 grams min.
- Mechanical life (cycles): 50 cycles min.

ELECTRICAL DATA:

- Rated current: SMD types: 1A
Thru-hole types: 2A
- Contact resistance: 20 mΩ max.
- Insulation resistance: 5000 MΩ min.
- Dielectric strength: 600 VRMS min.
- Capacitance: 2 pF max.

ENVIRONMENTAL DATA

- Operating temperature: -55/+125°C
- Vibration (No electrical discontinuity greater than 1µs): 10-2000 Hz, 15 g
- Climatic category (IEC): 55/85/21

PLCC Extraction Tool

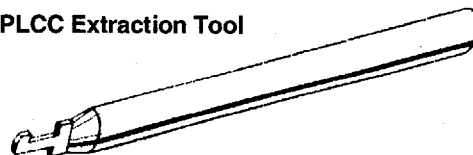

Part Number 8604-5450