

**Silicon NPN Planar RF Transistor**

**Applications**

Wide band amplifier up to GHz range.

**Features**

- High power gain
- Low noise figure
- High transition frequency

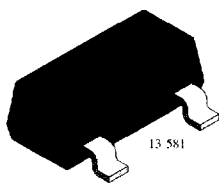
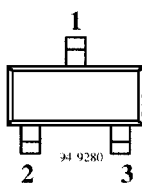

BFR92A Marking: + P2  
Plastic case (SOT 23)  
1= Collector; 2= Base; 3= Emitter

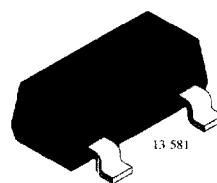
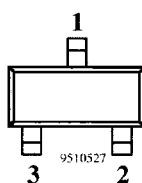

BFR92AR Marking: + P5  
Plastic case (SOT 23)  
1= Collector; 2= Base; 3= Emitter

**Absolute Maximum Ratings**

Parameters	Symbol	Value	Unit
Collector-base voltage	$V_{CB0}$	20	V
Collector-emitter voltage	$V_{CE0}$	15	V
Emitter-base voltage	$V_{EB0}$	2	V
Collector current	$I_C$	30	mA
Total power dissipation $T_{amb} \leq 60^\circ\text{C}$	$P_{tot}$	200	mW
Junction temperature	$T_j$	150	$^\circ\text{C}$
Storage temperature range	$T_{stg}$	-65 to +150	$^\circ\text{C}$

**Maximum Thermal Resistance**

Parameters	Symbol	Value	Unit
Junction ambient on glass fibre printed board (25 x 20 x 1.5) mm <sup>3</sup> plated with 35 $\mu\text{m}$ Cu	$R_{thJA}$	450	K/W

## Electrical DC Characteristics

$T_{amb} = 25^{\circ}\text{C}$

Parameters / Test Conditions	Symbol	Min.	Typ.	Max.	Unit
Collector-emitter cut-off current $V_{CE} = 20\text{ V}, V_{BE} = 0$	$I_{CES}$			100	$\mu\text{A}$
Collector-base cut-off current $V_{CB} = 10\text{ V}, I_E = 0$	$I_{CBO}$			100	nA
Emitter-base cut-off current $V_{EB} = 2\text{ V}, I_C = 0$	$I_{EBO}$			10	$\mu\text{A}$
Collector-emitter breakdown voltage $I_C = 1\text{ mA}, I_B = 0$	$V_{(BR)ICEO}$	15			V
DC forward current transfer ratio $V_{CE} = 10\text{ V}, I_C = 14\text{ mA}$	$h_{FE}$	65	100	150	

## Electrical AC Characteristics

$T_{amb} = 25^{\circ}\text{C}$

Parameters / Test Conditions	Symbol	Min.	Typ.	Max.	Unit
Transition frequency $V_{CE} = 10\text{ V}, I_C = 14\text{ mA}, f = 500\text{ MHz}$	$f_T$	5.0	6.0		GHz
Collector-base capacitance $V_{CB} = 10\text{ V}, f = 1\text{ MHz}$	$C_{cb}$		0.3		pF
Collector-emitter capacitance $V_{CE} = 10\text{ V}, f = 1\text{ MHz}$	$C_{ce}$		0.15		pF
Emitter-base capacitance $V_{EB} = 0.5\text{ V}, f = 1\text{ MHz}$	$C_{eb}$		0.65		pF
Noise figure $V_{CE} = 10\text{ V}, I_C = 2\text{ mA}, Z_S = 50\ \Omega, f = 800\text{ MHz}$	F		1.8		dB
Power gain $V_{CE} = 10\text{ V}, Z_S = 50\ \Omega, Z_L = Z_{Lopt}, I_C = 14\text{ mA}, f = 800\text{ MHz}$	$G_{pe}$		16		dB
Linear output voltage – two tone intermodulation test $V_{CE} = 10\text{ V}, I_C = 14\text{ mA}, d_{JM} = 60\text{ dB}, f_1 = 806\text{ MHz}, f_2 = 810\text{ MHz}, Z_S = Z_L = 50\ \Omega$	$V_1 = V_2$		120		mV
Third order intercept point $V_{CE} = 10\text{ V}, I_C = 14\text{ mA}, f = 800\text{ MHz}$	$IP_3$		24		dBm

**Common Emitter S-Parameters**  
**Z<sub>0</sub> = 50 Ω**

V <sub>CE</sub> /V	I <sub>C</sub> /mA	f/MHz	S <sub>11</sub>		S <sub>21</sub>		S <sub>12</sub>		S <sub>22</sub>	
			LIN MAG	ANG	LIN MAG	ANG	LIN MAG	ANG	LIN MAG	ANG
				deg		deg		deg		deg
5	2	100	0.902	-17.5	6.38	164.6	0.025	79.9	0.978	-7.6
		300	0.761	-50.2	5.51	137.8	0.064	63.1	0.859	-19.3
		500	0.577	-76.8	4.48	117.8	0.086	53.7	0.736	-24.2
		800	0.399	-105.3	3.28	98.9	0.104	49.7	0.642	-25.3
		1000	0.339	-121.9	2.79	90.0	0.114	50.3	0.618	-26.0
		1200	0.303	-138.1	2.45	82.1	0.124	51.1	0.603	-28.0
		1500	0.284	-163.3	2.07	71.4	0.140	53.1	0.577	-31.2
		1800	0.272	172.9	1.79	62.5	0.157	55.5	0.560	-33.9
	2000	0.278	159.4	1.65	57.3	0.171	56.6	0.558	-36.0	
	5	100	0.783	-27.2	12.84	155.8	0.023	76.3	0.934	-12.7
		300	0.534	-69.6	9.12	122.8	0.052	61.9	0.711	-25.1
		500	0.351	-97.6	6.41	104.8	0.068	59.5	0.580	-25.6
		800	0.220	-128.3	4.28	89.8	0.091	61.1	0.518	-22.1
		1000	0.188	-145.2	3.53	82.9	0.107	62.5	0.515	-22.2
		1200	0.175	-162.0	3.04	76.5	0.124	62.8	0.510	-24.1
		1500	0.189	175.1	2.51	67.8	0.149	63.0	0.494	-27.3
		1800	0.200	153.5	2.16	60.2	0.175	62.4	0.483	-30.0
	2000	0.214	140.6	1.98	55.8	0.194	61.6	0.481	-32.6	
	10	100	0.641	-38.1	19.40	146.3	0.020	73.2	0.869	-17.6
		300	0.362	-85.8	11.09	112.0	0.043	65.2	0.597	-26.0
		500	0.229	-116.7	7.27	97.3	0.062	66.3	0.496	-22.9
		800	0.148	-151.6	4.69	84.9	0.089	68.1	0.465	-18.1
		1000	0.136	-168.5	3.83	79.0	0.108	68.1	0.473	-18.4
		1200	0.133	176.8	3.27	73.4	0.127	67.8	0.473	-20.6
		1500	0.160	158.3	2.70	65.7	0.156	66.5	0.461	-24.6
		1800	0.183	139.4	2.30	58.9	0.184	64.8	0.452	-27.4
	2000	0.198	130.4	2.12	54.8	0.203	63.5	0.450	-30.1	
	14	100	0.566	-44.3	22.20	141.5	0.019	72.7	0.832	-19.4
		300	0.301	-94.2	11.58	108.1	0.041	67.5	0.560	-25.1
		500	0.195	-127.0	7.43	94.6	0.060	69.0	0.475	-20.9
		800	0.137	-164.6	4.78	83.2	0.089	70.1	0.456	-16.5
		1000	0.129	-179.9	3.88	77.6	0.109	69.9	0.466	-17.1
		1200	0.132	167.7	3.30	72.3	0.128	69.1	0.469	-19.4
		1500	0.162	153.1	2.72	64.9	0.157	67.5	0.456	-23.4
		1800	0.183	136.6	2.32	58.1	0.185	65.6	0.448	-26.3
	2000	0.204	127.4	2.13	54.1	0.205	64.1	0.446	-29.2	
	20	100	0.484	-52.5	24.55	136.0	0.018	72.0	0.788	-20.7
		300	0.251	-106.2	11.67	104.3	0.039	69.5	0.531	-22.8
		500	0.181	-141.8	7.37	92.1	0.058	71.5	0.466	-18.3
		800	0.144	-177.4	4.70	81.3	0.088	72.0	0.456	-14.4
		1000	0.138	169.3	3.82	76.0	0.108	71.4	0.469	-15.3
		1200	0.145	159.1	3.26	70.9	0.127	70.6	0.472	-18.1
		1500	0.179	148.3	2.67	63.7	0.157	68.4	0.461	-22.4
		1800	0.202	133.7	2.28	57.0	0.185	66.4	0.453	-25.4
	2000	0.220	125.9	2.10	52.8	0.205	64.8	0.452	-28.4	

## Common Emitter S-Parameters

$Z_0 = 50 \Omega$

V <sub>CE</sub> /V	I <sub>C</sub> /mA	f/MHz	S <sub>11</sub>		S <sub>21</sub>		S <sub>12</sub>		S <sub>22</sub>	
			LIN MAG	ANG	LIN MAG	ANG	LIN MAG	ANG	LIN MAG	ANG
				deg		deg		deg		deg
10	2	100	0.915	-16.2	6.32	165.5	0.020	80.5	0.981	-6.2
		300	0.780	-46.7	5.56	139.6	0.054	65.1	0.883	-16.1
		500	0.597	-71.2	4.57	119.9	0.073	55.8	0.778	-20.4
		800	0.405	-97.6	3.37	101.0	0.089	52.2	0.692	-21.6
		1000	0.339	-113.1	2.87	92.3	0.098	53.0	0.677	-22.4
		1200	0.294	-129.6	2.53	84.2	0.107	54.3	0.663	-24.0
		1500	0.261	-155.8	2.13	73.7	0.121	56.8	0.643	-27.0
		1800	0.240	179.2	1.84	64.8	0.136	59.2	0.630	-29.6
	2000	0.243	163.2	1.70	59.8	0.149	61.1	0.630	-31.4	
	5	100	0.816	-24.3	12.50	157.4	0.019	77.2	0.947	-10.3
		300	0.569	-62.7	9.15	125.3	0.044	63.6	0.761	-20.5
		500	0.372	-87.9	6.55	106.9	0.059	60.6	0.647	-21.1
		800	0.220	-114.2	4.41	91.6	0.079	62.3	0.592	-18.8
		1000	0.175	-129.6	3.63	84.6	0.093	63.9	0.590	-19.1
		1200	0.153	-145.8	3.13	78.3	0.107	64.8	0.589	-20.8
		1500	0.153	-175.7	2.59	69.7	0.129	65.5	0.576	-24.1
		1800	0.157	158.0	2.22	62.1	0.152	65.5	0.567	-26.6
	2000	0.170	143.4	2.04	57.9	0.168	65.3	0.567	-28.7	
	10	100	0.696	-33.7	18.83	148.4	0.017	74.6	0.896	-13.8
		300	0.397	-75.7	11.20	114.4	0.038	66.4	0.666	-20.8
		500	0.237	-101.2	7.41	99.0	0.054	67.0	0.577	-18.6
		800	0.132	-130.2	4.81	86.4	0.078	68.9	0.553	-15.5
		1000	0.103	-149.3	3.92	80.4	0.094	69.4	0.560	-16.0
		1200	0.097	-165.8	3.35	75.0	0.111	69.5	0.561	-18.2
		1500	0.116	167.2	2.76	67.5	0.136	69.0	0.551	-21.9
		1800	0.133	141.3	2.36	60.4	0.160	67.9	0.545	-24.4
	2000	0.148	129.4	2.16	56.4	0.178	66.8	0.549	-27.1	
	14	100	0.639	-38.8	21.41	143.8	0.016	73.2	0.866	-15.2
300		0.339	-82.4	11.61	110.2	0.036	67.5	0.636	-19.8	
500		0.199	-110.0	7.52	96.3	0.053	69.4	0.562	-16.9	
800		0.113	-144.1	4.83	84.4	0.077	70.7	0.549	-14.2	
1000		0.093	160.9	3.93	78.9	0.094	71.1	0.556	-14.9	
1200		0.090	179.0	3.36	73.7	0.110	70.5	0.560	-17.3	
1500		0.118	158.6	2.76	66.4	0.136	69.8	0.550	-21.0	
1800		0.137	137.7	2.35	59.5	0.161	68.4	0.546	-24.0	
2000	0.155	125.7	2.16	55.6	0.178	67.4	0.548	-26.5		
20	100	0.576	-45.8	23.38	138.5	0.015	72.0	0.836	-15.8	
	300	0.286	-91.7	11.55	106.1	0.034	69.0	0.620	-17.7	
	500	0.177	-123.1	7.34	93.4	0.051	71.3	0.565	-14.7	
	800	0.113	-161.1	4.69	82.2	0.075	72.4	0.557	-12.6	
	1000	0.101	-177.3	3.81	77.1	0.092	72.4	0.568	-13.8	
	1200	0.107	168.1	3.24	72.0	0.109	71.9	0.571	-16.4	
	1500	0.136	152.5	2.67	64.8	0.134	70.9	0.564	-20.4	
	1800	0.160	133.1	2.27	58.1	0.159	69.5	0.559	-23.5	
2000	0.181	124.2	2.09	54.0	0.176	68.4	0.560	-25.9		

**Typical Characteristics** ( $T_j = 25^\circ\text{C}$  unless otherwise specified)

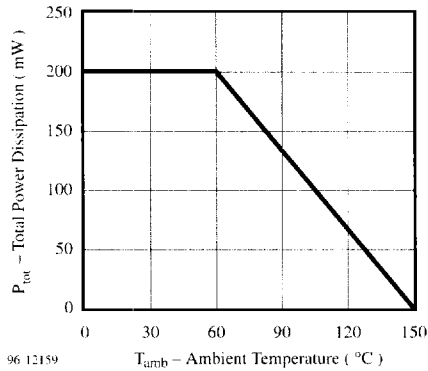

Figure 1. Total Power Dissipation vs. Ambient Temperature

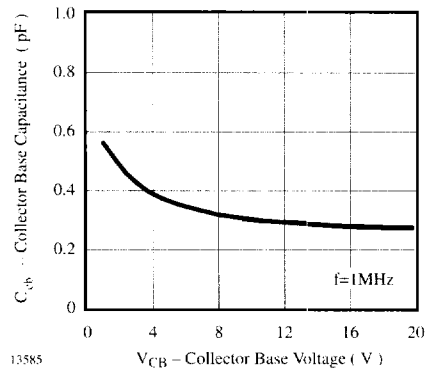

Figure 3. Collector Base Capacitance vs. Collector Base Voltage

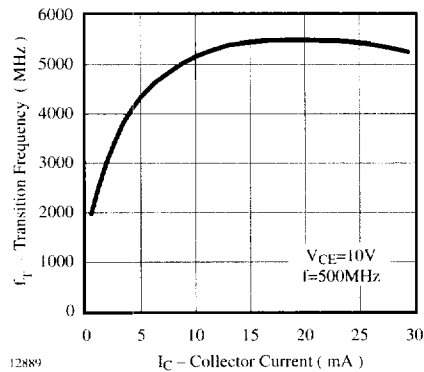

Figure 2. Transition Frequency vs. Collector Current

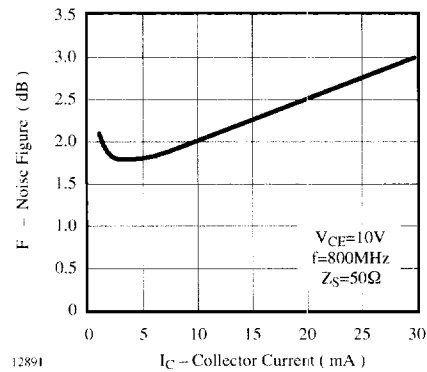

Figure 4. Noise Figure vs. Collector Current

$V_{CE} = 10 \text{ V}; I_C = 14 \text{ mA}; Z_0 = 50 \Omega$

$S_{11}$

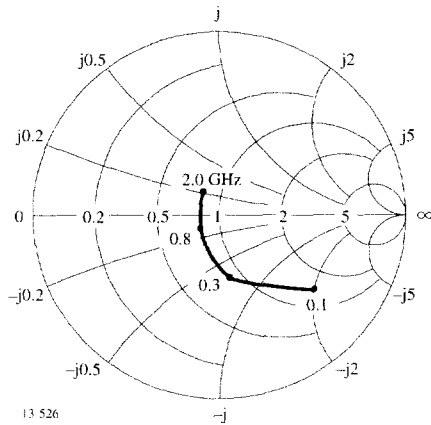

Figure 5. Input reflection coefficient

$S_{12}$

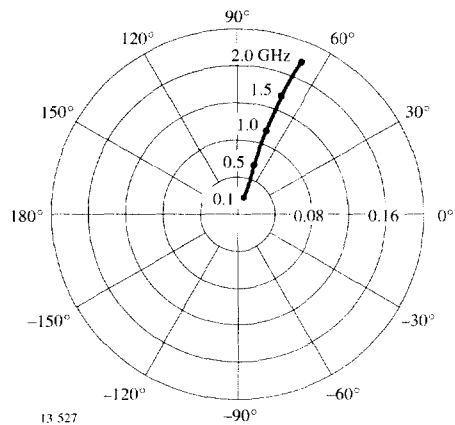

Figure 7. Reverse transmission coefficient

$S_{21}$

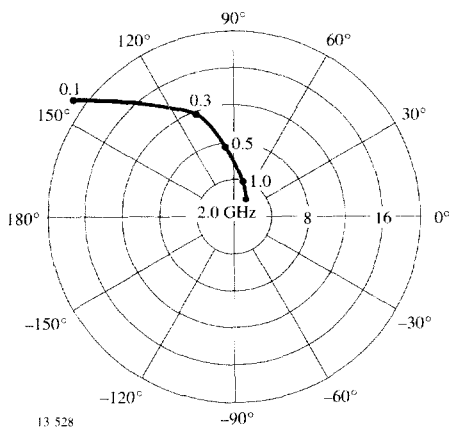

Figure 6. Forward transmission coefficient

$S_{22}$

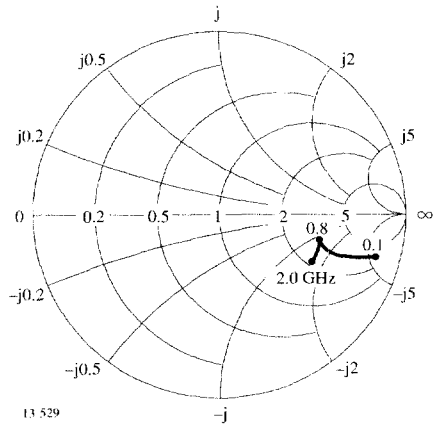
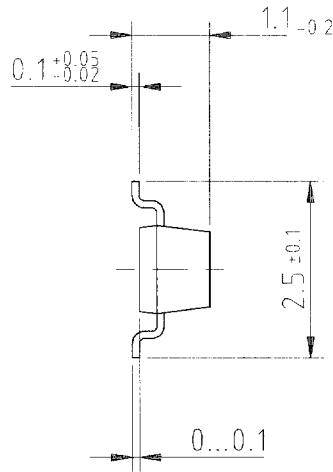
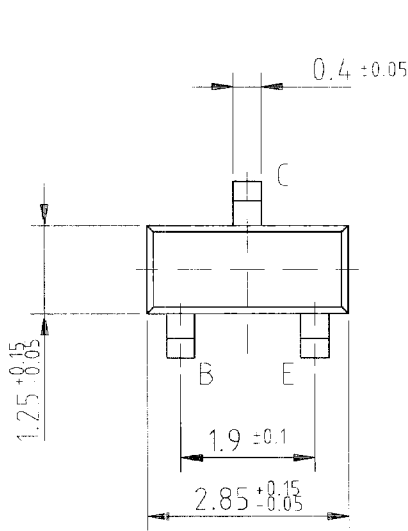
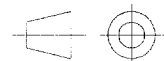

Figure 8. Output reflection coefficient

**Dimensions of BFR92A in mm**



95 11346

  
technical drawings  
according to DIN  
specifications

**Dimensions of BFR92AR in mm**

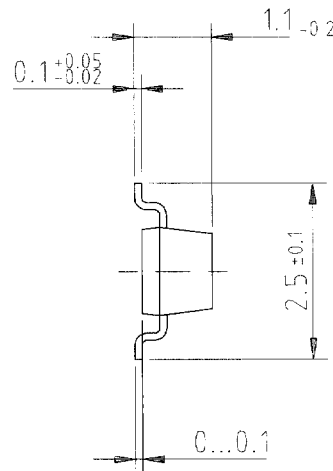
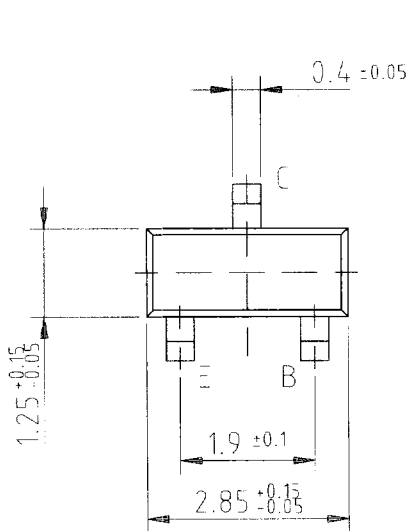

95 11347

  
technical drawings  
according to DIN  
specifications