

### Features

- Diffused Junction
- Low Forward Voltage Drop
- High Surge Current Capability
- High Reliability
- Ideally Suited for Use in High Frequency SMPS, Inverters and As Free Wheeling Diodes

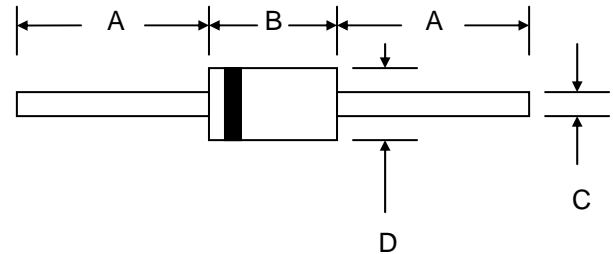

### Mechanical Data

- Case: DO-201AD, Molded Plastic
- Terminals: Plated Leads Solderable per MIL-STD-202, Method 208
- Polarity: Cathode Band
- Weight: 1.2 grams (approx.)
- Mounting Position: Any
- Marking: Type Number
- **Lead Free: For RoHS / Lead Free Version, Add "-LF" Suffix to Part Number, See Page 4**

DO-201AD		
Dim	Min	Max
A	25.4	—
B	7.20	9.50
C	1.20	1.30
D	4.80	5.30
All Dimensions in mm		

### Maximum Ratings and Electrical Characteristics @T<sub>A</sub>=25°C unless otherwise specified

Single Phase, half wave, 60Hz, resistive or inductive load.  
For capacitive load, derate current by 20%.

Characteristic	Symbol	UF 5400	UF 5401	UF 5402	UF 5403	UF 5404	UF 5406	UF 5407	UF 5408	Unit
Peak Repetitive Reverse Voltage	V <sub>RRM</sub>	50	100	200	300	400	600	800	1000	V
Working Peak Reverse Voltage	V <sub>RWM</sub>									
DC Blocking Voltage	V <sub>R</sub>									
RMS Reverse Voltage	V <sub>R(RMS)</sub>	35	70	140	210	280	420	560	700	V
Average Rectified Output Current (Note 1) @T <sub>A</sub> = 55°C	I <sub>O</sub>	3.0								A
Non-Repetitive Peak Forward Surge Current 8.3ms Single Half Sine-Wave Superimposed on Rated Load (JEDEC Method)	I <sub>FSM</sub>	150								A
Forward Voltage @I <sub>F</sub> = 3.0A	V <sub>FM</sub>	1.0			1.3		1.7			V
Peak Reverse Current @T <sub>A</sub> = 25°C At Rated DC Blocking Voltage @T <sub>A</sub> = 100°C	I <sub>RM</sub>	10 100								μA
Reverse Recovery Time (Note 2)	t <sub>r</sub>	50				75				nS
Typical Junction Capacitance (Note 3)	C <sub>J</sub>	45				36				pF
Typical Thermal Resistance Junction to Ambient (Note 1)	R <sub>JA</sub>	20								°C/W
Typical Thermal Resistance Junction to Lead (Note 1)	R <sub>JL</sub>	8.5								
Operating Temperature Range	T <sub>J</sub>	-65 to +125								°C
Storage Temperature Range	T <sub>STG</sub>	-65 to +150								°C

Note: 1. Leads maintained at ambient temperature at a distance of 9.5mm from the case.  
2. Measured with I<sub>F</sub> = 0.5A, I<sub>R</sub> = 1.0A, I<sub>RR</sub> = 0.25A.  
3. Measured at 1.0 MHz and Applied Reverse Voltage of 4.0V D.C.

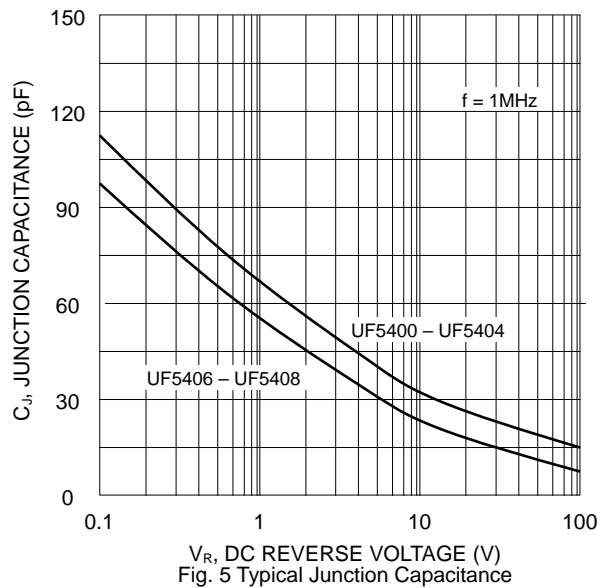
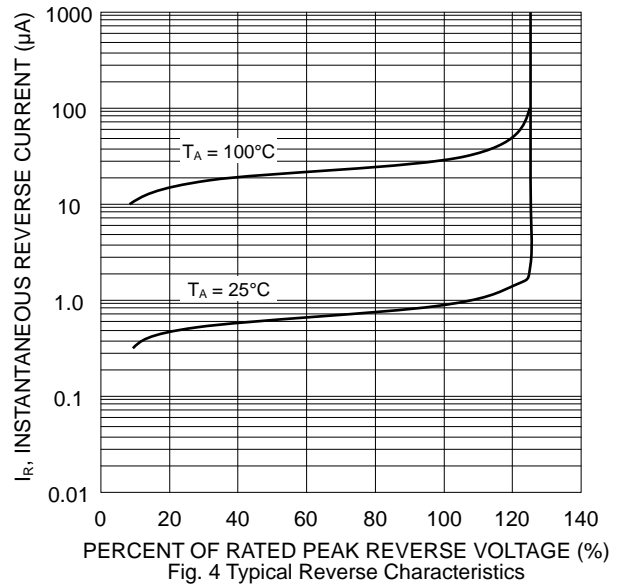
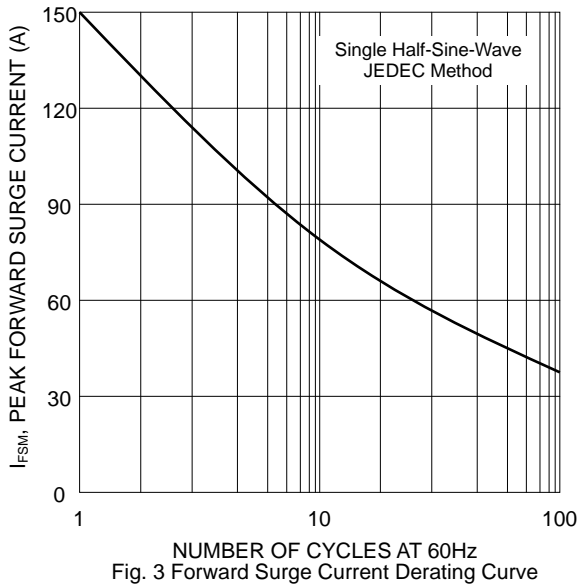
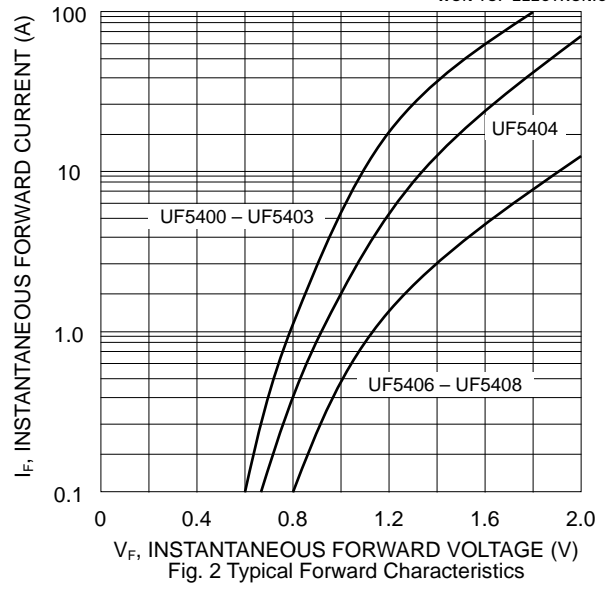
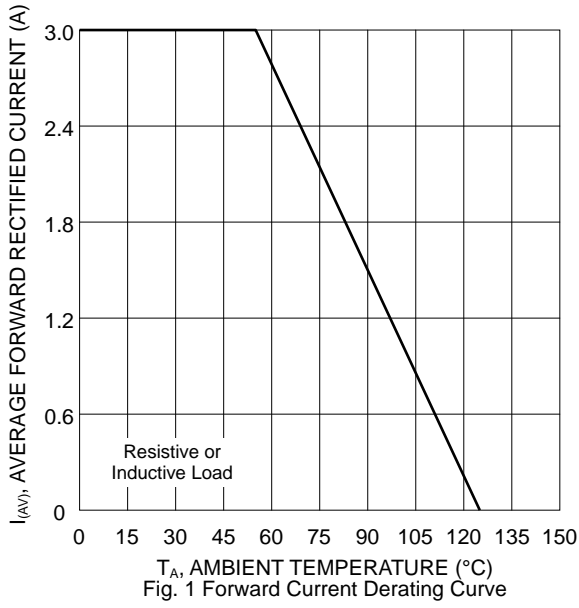

## MARKING INFORMATION

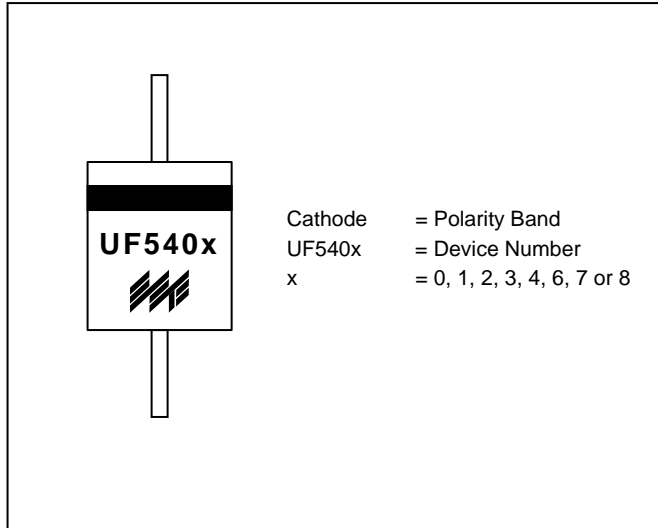

## TAPING SPECIFICATIONS

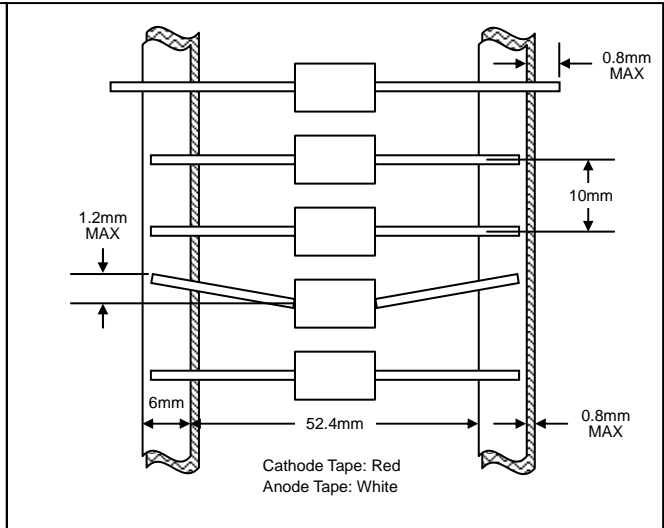

## PACKAGING INFORMATION

### TAPE & REEL

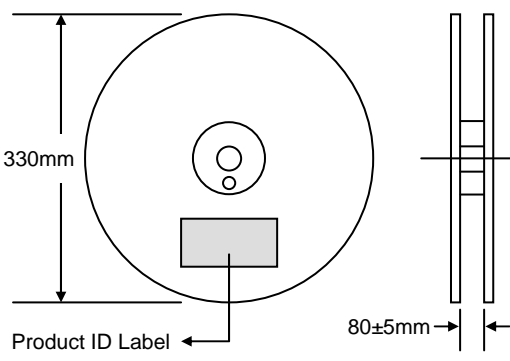

330mm  
 Product ID Label  
 80±5mm

### TAPE & BOX

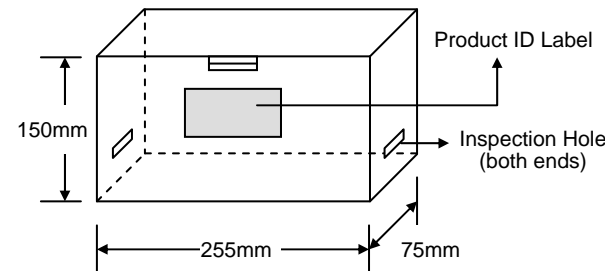

150mm  
 255mm  
 75mm  
 Product ID Label  
 Inspection Hole (both ends)

### BULK

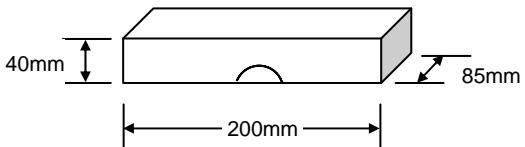

40mm  
 200mm  
 85mm

Packaging	Reel Diameter / Box Size (mm)	Quantity (PCS)	Carton Size (mm)	Quantity (PCS)	Approx. Gross Weight (KG)
<b>TAPE &amp; REEL</b>	330	1,200	370 x 370 x 420	6,000	10.0
<b>TAPE &amp; BOX</b>	255 x 75 x 150	1,200	400 x 273 x 415	12,000	17.0
<b>BULK</b>	200 x 85 x 40	500	459 x 214 x 256	12,500	16.0

**Note:** 1. Paper reel, white or gray color. Core material: plastic or metal.  
 2. Components are packed in accordance with EIA standard RS-296-E.

## ORDERING INFORMATION

Product No.	Package Type	Shipping Quantity
UF540x-T3	DO-201AD	1200/Tape & Reel
<b>UF540x-TB</b>	DO-201AD	1200/Tape & Box
UF540x	DO-201AD	500 Units/Box

1. Products listed in **bold** are WTE **Preferred** devices.
2. Shipping quantity given is for minimum packing quantity only. For minimum order quantity, please consult the Sales Department.
3. **To order RoHS / Lead Free version (with Lead Free finish), add "-LF" suffix to part number above. For example, UF5400-TB-LF.**

WON-TOP ELECTRONICS and  are registered trademarks of Won-Top Electronics Co., Ltd (WTE). WTE has checked all information carefully and believes it to be correct and accurate. However, WTE cannot assume any responsibility for inaccuracies. Furthermore, this information does not give the purchaser of semiconductor devices any license under patent rights to manufacturer. WTE reserves the right to change any or all information herein without further notice.

**WARNING:** DO NOT USE IN LIFE SUPPORT EQUIPMENT. WTE power semiconductor products are not authorized for use as critical components in life support devices or systems without the express written approval.

**Won-Top Electronics Co., Ltd.**  
No. 44 Yu Kang North 3rd Road,  
Chine Chen Dist., Kaohsiung 806, Taiwan  
**Phone:** 886-7-822-5408 or 886-7-822-5410  
**Fax:** 886-7-822-5417  
**Email:** sales@wontop.com  
**Internet:** <http://www.wontop.com>

*We power your everyday.*