

## DUAL SCHOTTKY RECTIFIERS IN HERMETIC ISOLATED TO258AA PACKAGE

SM3S42\*\*\*

These devices offer two Schottky rectifiers mounted in isolated and hermetically sealed packages. Use of Beryllia substrates ensures the lowest possible thermal impedance, thereby decreasing losses and providing increased efficiency. Typical applications include switching power supplies, inverters and use as free wheeling diodes.

### FEATURES

Low Forward Voltage  
 High Surge Capability  
 Guard Ring for Stress Protection  
 High Temp. Glass Passivated Junction  
 Available with High Reliability Screening

### QUICK REFERENCE DATA

- $V_R = 45V$
- $I_F = 30A$
- $I_{FSM} = 150 A$
- $V_F = 0.78V$

### ABSOLUTE MAXIMUM RATINGS (@ 25°C unless otherwise specified)

Parameter	Symbol	SM3S42*	Units
Working Reverse Voltage	$V_{RWM}$	45	V
Repetitive Reverse Voltage	$V_{RRM}$	45	V
Average Forward Current ( $T_C=100^\circ C$ )	$I_{F(AV)}$	30	A
Repetitive Peak Surge Current	$I_{FRM}$	64	A
Non-Repetitive Peak Surge Current (1)	$I_{FSM}$	150	A
Operating Junction and Storage Temperature Range	$T_{STG}, T_J$	-65 to 150	°C

(1)  $t_p = 8.3ms$ , @  $V_R$  &  $T_J$  max

## SM3S42\*\*\*

DUAL SCHOTTKY RECTIFIERS IN HERMETIC  
ISOLATED TO258AA PACKAGE

## ELECTRICAL CHARACTERISTICS (@ 25°C unless otherwise specified)

Parameter	Symbol	SM3S42*	Units	TEST CONDITIONS
Forward Voltage Drop max. (1)	V <sub>F</sub>	0.60	V	I <sub>F</sub> =15A
		0.56		I <sub>F</sub> =15A, T <sub>C</sub> =125°C
Forward Voltage Drop max. (1)	V <sub>F</sub>	0.78	V	I <sub>F</sub> =30A
		0.75		I <sub>F</sub> =30A, T <sub>C</sub> =125°C
Reverse Current max. (1)	I <sub>R</sub>	0.2	mA	V <sub>R</sub> =V <sub>RRM</sub>
		40		V <sub>R</sub> =V <sub>RRM</sub> , T <sub>C</sub> =125°C

(1) Pulse Test: Pulsewidth = 300μs; Duty Cycle &lt; 2%

## THERMAL RESISTANCE

Symbol	Parameter	Device	Max.	Units
R <sub>θJC</sub>	Junction to Case	ALL	1.5	°C/W
R <sub>θJA</sub>	Junction to Ambient		60	

**DUAL SCHOTTKY RECTIFIERS IN HERMETIC ISOLATED TO258AA PACKAGE**

**SM3S42\*\*\***

**MECHANICAL OUTLINE AND CONFIGURATION**

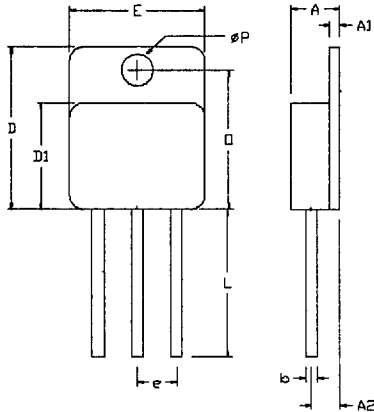

DIM	MILLIMETERS		INCHES	
	MIN	MAX	MIN.	MAX
A	6.09	6.85	.240	.270
A1	.88	1.14	.035	.045
A2	3.55	BSC	.140	BSC
b	1.39	1.65	.055	.065
D	20.70	21.20	.815	.835
D1	13.46	13.97	.530	.550
e	5.08	BSC	.200	BSC
E	17.39	17.65	.685	.695
L	12.70	19.05	.500	.750
P	17.70	17.95	.697	.707
P	3.93	4.19	.155	.165

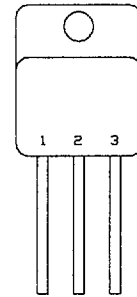

See ordering information for available pinout configurations

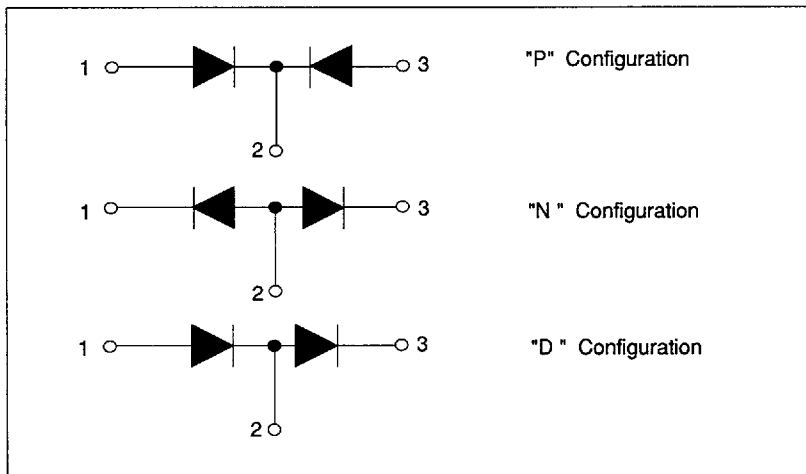

**SM3S42\*\*\*****DUAL SCHOTTKY RECTIFIERS IN HERMETIC  
ISOLATED TO258AA PACKAGE**

---

**ORDERING INFORMATION**

The last three characters of the SEMTECH part numbering system identify the pinout, lead bend configuration and the level of testing required. All devices are tested for hermeticity and compliance to the appropriate electrical characteristics.

**Pinout**

- P- Positive Center Tap
- N- Negative Center Tap
- D- Doubler

**Lead Bend**

- S- Straight Leads
- D- 90° Bend Down (see fig 10 at the end of this section)

**Screening**

- U- Unscreened
- T- Screening per MIL-S-19500 Table II

(Unless specified by the customer, devices will have straight leads and be unscreened.)

e.g SM3S42PDT is a SM3S42 in positive center tap configuration, with bent leads and screening to MIL-S-19500 Table II.

PACKAGE OUTLINE DRAWINGS

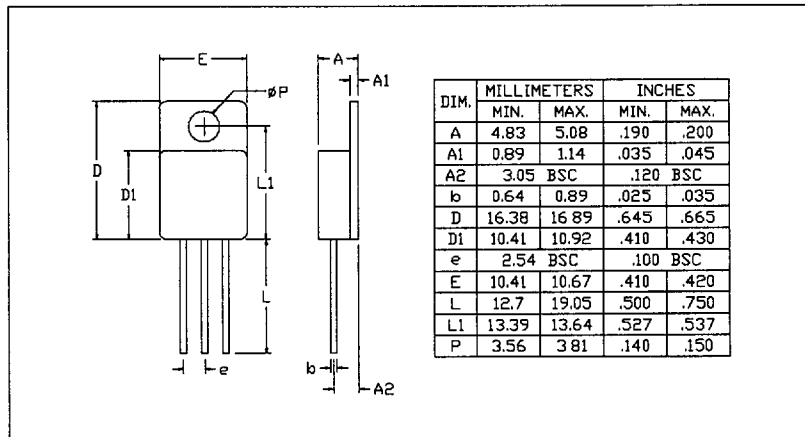

Fig.1 STRAIGHT LEAD TO257AA (S-SUFFIX)

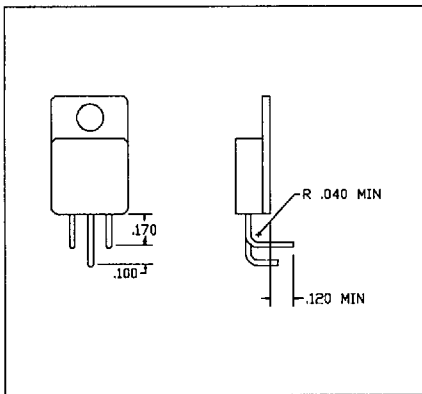

Fig.2 CLAW BEND TO257AA (C-SUFFIX)

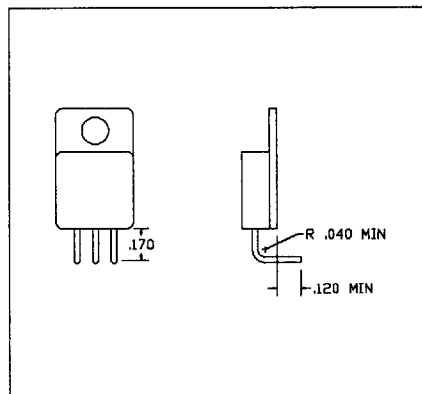

Fig.3 BENT DOWN LEAD TO257AA (D-SUFFIX)

PACKAGE OUTLINE DRAWINGS

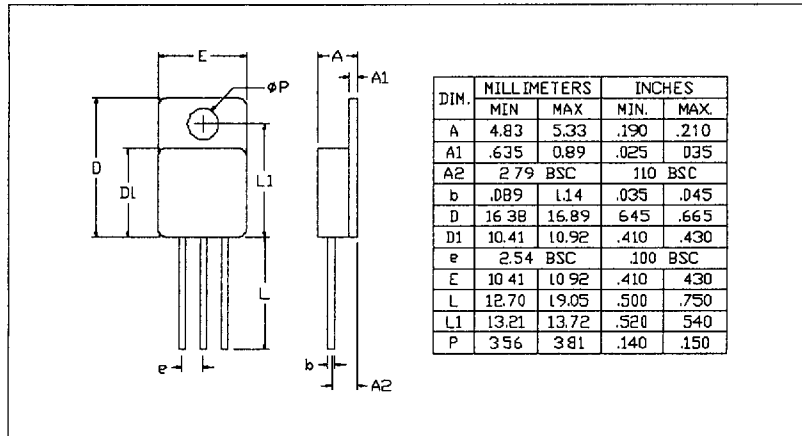

Fig.4 STRAIGHT LEAD TO257AB (S-SUFFIX)

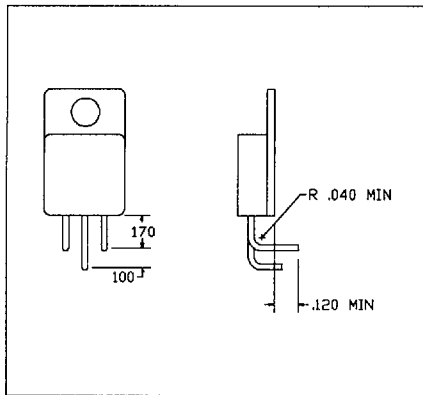

Fig.5 CLAW BEND TO257AB (C-SUFFIX)

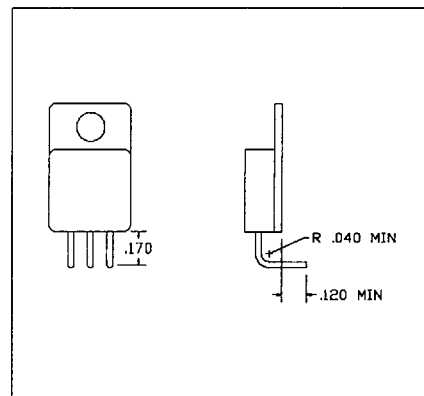

Fig.6 BENT DOWN LEAD TO257AB (D-SUFFIX)

PACKAGE OUTLINE DRAWINGS

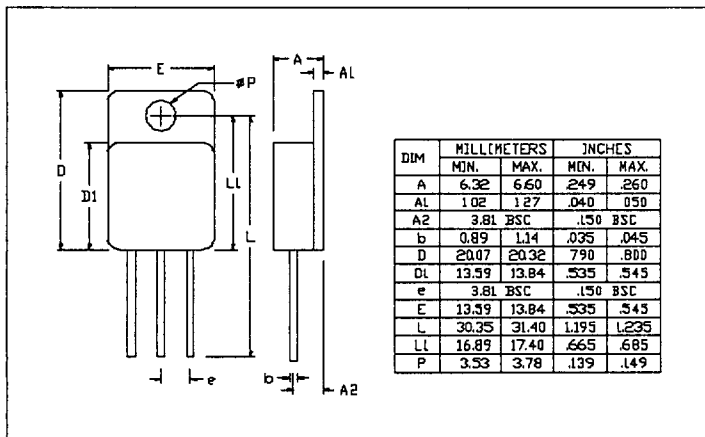

Fig.7 STRAIGHT LEAD TO254AA (S-SUFFIX)

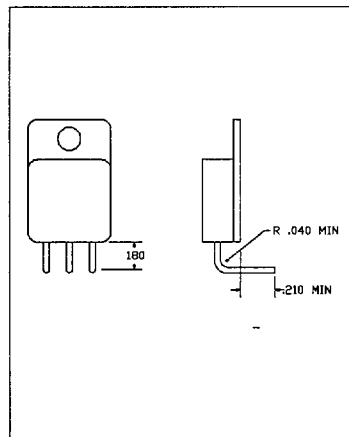

Fig.8 BENT DOWN LEAD TO254AA (D-SUFFIX)

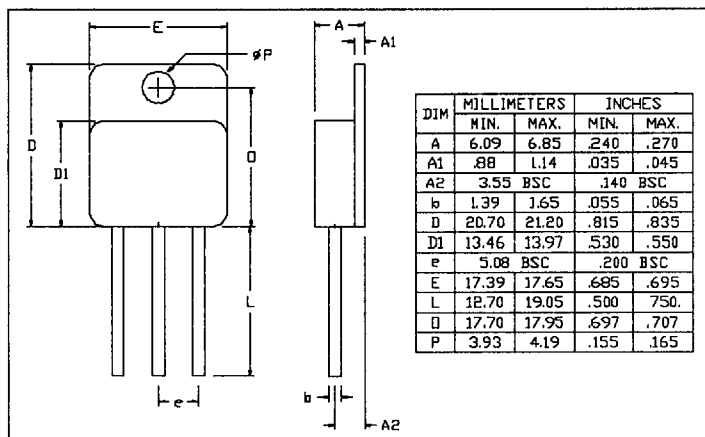

Fig.9 STRAIGHT LEAD TO258AA (S-SUFFIX)

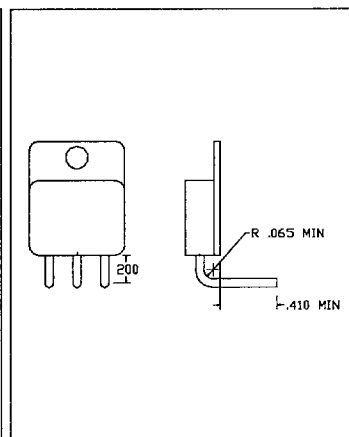

Fig.10 BENT DOWN LEAD TO258AA (D-SUFFIX)

PACKAGE OUTLINE DRAWINGS

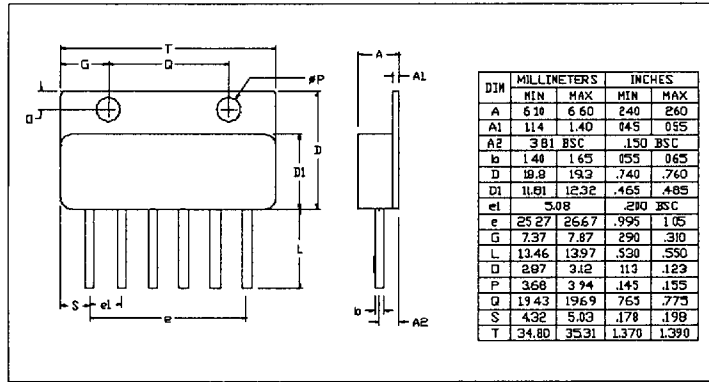

Fig.11 STRAIGHT LEAD 6 PIN TOP MOUNT (S-SUFFIX)

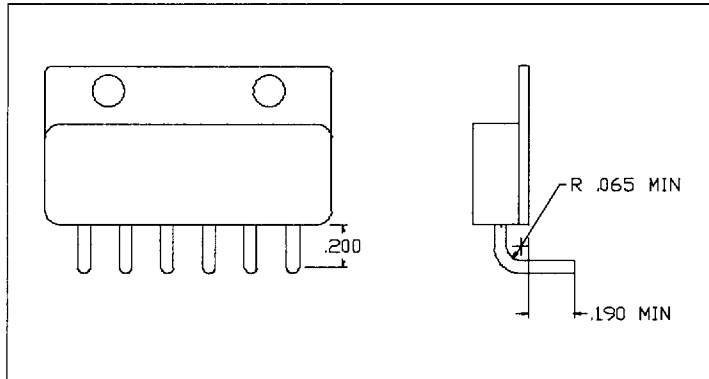

Fig.12 BENT DOWN 6 PIN TOP MOUNT (D-SUFFIX)

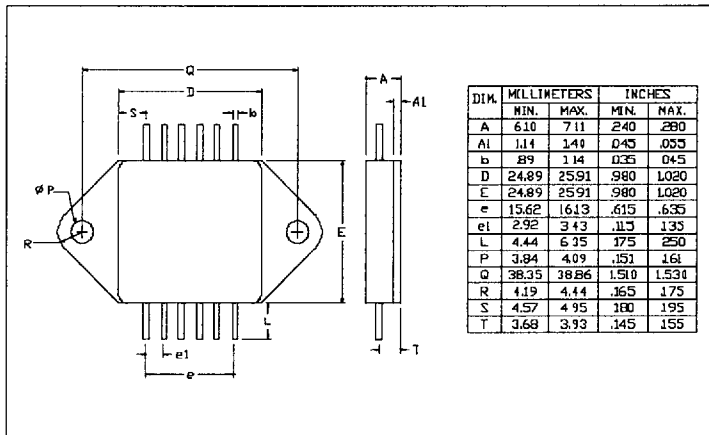

Fig.13 12 PIN "QUADPACK"