

Customer Information Sheet

DRAWING No.: M80-4C1XXXXFC, M80-4C1XXXXFC-00-000-00-000 SHT 2 OF 2

IF IN DOUBT - ASK

(C)

NOT TO SCALE

THIRD ANGLE PROJECTION

ALL DIMENSIONS IN mm

SPECIFICATIONS:

MATERIAL:
 Moulding = GLASS-FILLED PPS, UL94V-0, BLACK
 CONTACT CLIP = BERYLLIUM COPPER
 CONTACT SHELL = BRASS
 101-SCREW, COLLAR = STAINLESS STEEL
 SPRING = MUSIC WIRE

FINISH:
 05 = 0.3µ GOLD CLIP, 0.25-0.3µ GOLD SHELL
 42 = 0.3µ GOLD CLIP, 3.5-5.0µ 100% TIN OVER NICKEL SHELL
 05 & 42 = TIN COATED SPRINGS

ELECTRICAL:
 CURRENT RATING AT 25°C = 3.0A MAX
 CURRENT RATING AT 85°C = 2.2A MAX
 WORKING VOLTAGE = 120V AC/DC
 VOLTAGE PROOF = 360V AC/DC
 CONTACT RESISTANCE = 25 mΩ MAX
 INSULATION RESISTANCE = 100 MΩ MIN

MECHANICAL:
 INSERTION FORCE (∅0.5mm GAUGE) = 2.8N MAX
 WITHDRAWAL FORCE (∅0.5mm GAUGE) = 0.2N MIN

ENVIRONMENTAL:
 TEMPERATURE RANGE = -55°C TO +121°C

PACKING:
 LOOSE
 FOR COMPLETE SPECIFICATION, SEE COMPONENT SPECIFICATION C005XX (LATEST ISSUE)

NOTES:

- CONNECTOR IS SUPPLIED WITH CONTACTS LOOSE.
- FOR EXTRA CONTACTS, USE PART No.'s.
 M80-0130001 FOR M80-4C1XX42FC-00-000-00-000
 M80-0130005 FOR M80-4C1XX05FC-00-000-00-000
- RECOMMENDED WIRE TYPE = BS 3G 210 TYPE A, PTFE INSULATED 24-28 AWG. MAX INSULATION DIAMETER = ∅1.10mm, STRIP WIRE BY 2.00mm.
- RECOMMENDED HAND CRIMP TOOL = M22520/2-01 WITH POSITIONER T5747.
- CONTACT INSERTION & EXTRACTION TOOL = Z80-280
- INSTRUCTION SHEETS ARE AVAILABLE.
- SPRING LOAD WHEN SOLID = 2.642N.
 SPRING RATE = 1.32N/mm.
- LENGTH WILL BE 1.9mm WHEN 101-SCREWS ARE ENGAGED WITH RETAINERS IN MATING CONNECTOR.
- ALL PART LABELLING TO BE AS ORDER CODE, EITHER WITH TRAILING ZEROS OR LEFT BLANK AS PER ORDER CODE EXAMPLES 1 AND 2.

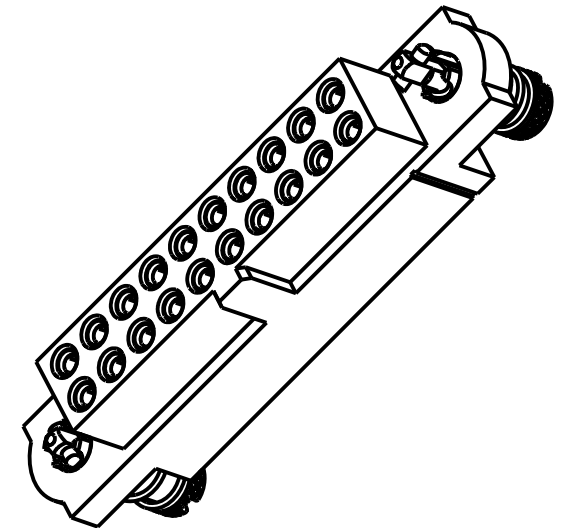
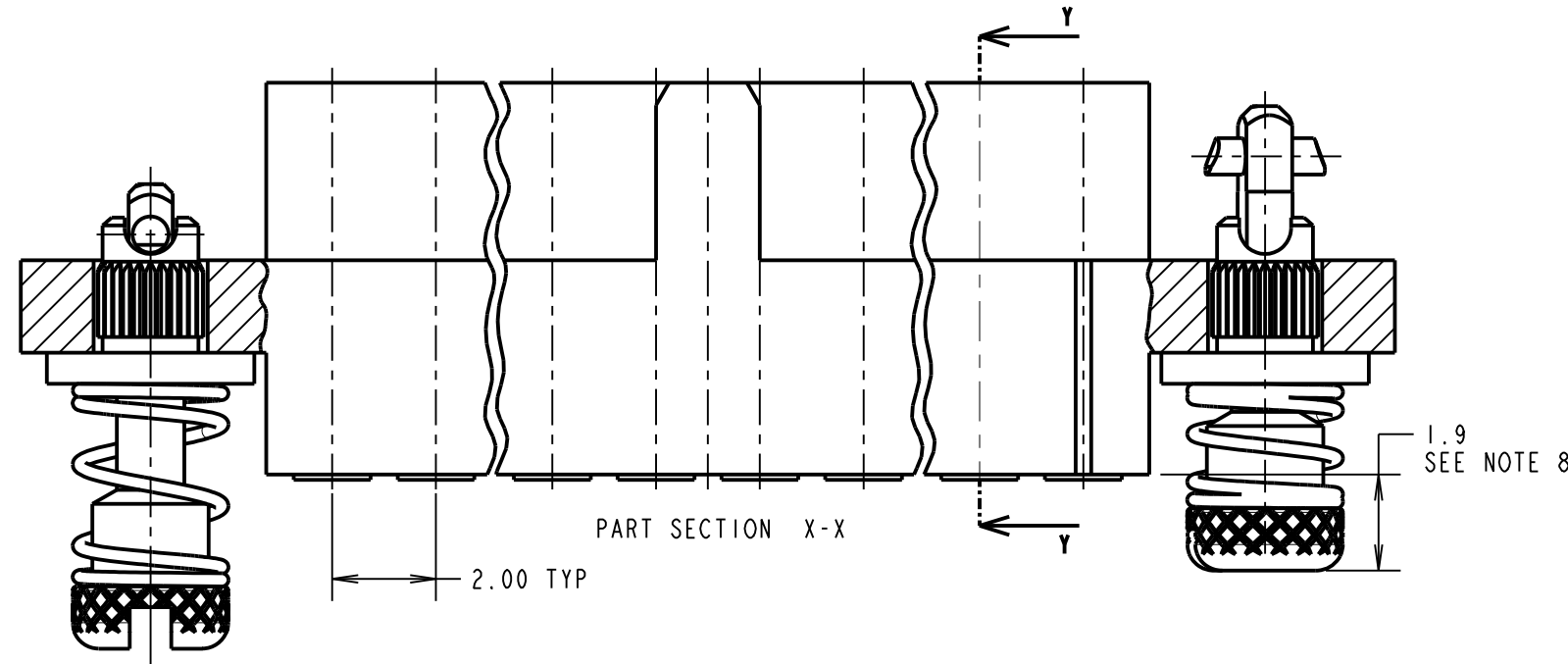
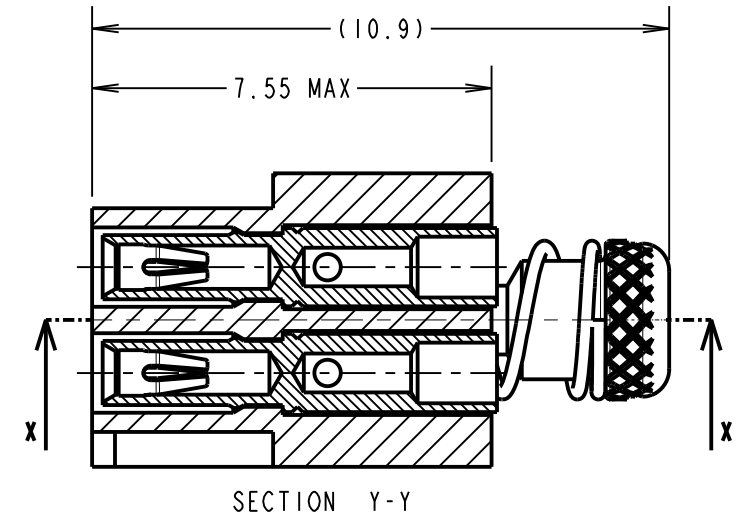
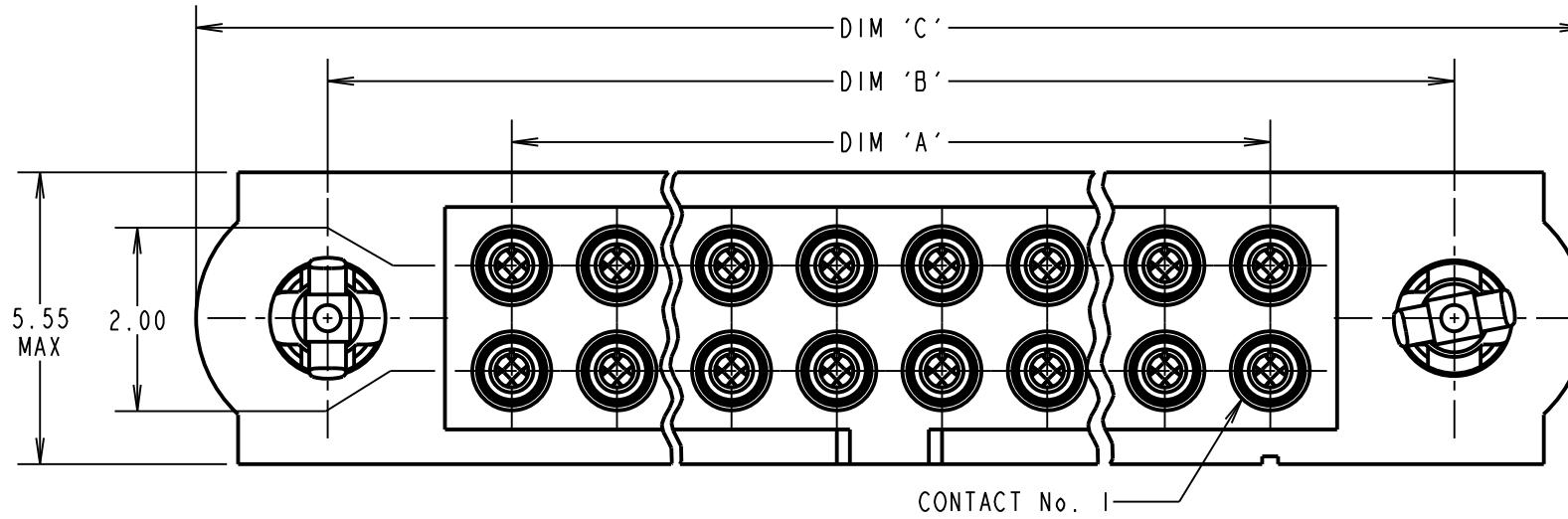

DIMENSION	CALCULATION
DIM 'A'	TOTAL No. OF CONTACTS - 2
DIM 'B'	TOTAL No. OF CONTACTS + 5
DIM 'C'	TOTAL NUMBER CONTACTS + 10

EXAMPLE ORDER CODE 1: CONNECTOR WITH 20 SIGNAL CONTACTS, GOLD CLIP AND 100% TIN SHELL

M80-4C12042FC-00-000-00-000

DIM 'A' = 18.00mm, DIM 'B' = 25.00mm, DIM 'C' = 30.00mm.

EXAMPLE ORDER CODE 2: CONNECTOR WITH 20 SIGNAL CONTACTS, GOLD CLIP AND 100% TIN SHELL

M80-4C12042FC

DIM 'A' = 18.00mm, DIM 'B' = 25.00mm, DIM 'C' = 30.00mm.



CONTACT: (QTY = TOTAL No. OF CONTACTS)
 M80-01300XX (SEE NOTE 2)

05 = GOLD CLIP, GOLD SHELL
 01 = GOLD CLIP, 100% TIN OVER NICKEL SHELL

ORDER CODE: **M80-4C1XXXXFC-XX-XXX-XX-XXX**

TOTAL No. OF CONTACTS
 04 TO 50
 (EVEN NUMBERS ONLY)

FINISH CODE
 05 - GOLD CLIP, GOLD SHELL
 42 - GOLD CLIP, 100% TIN, OVER NICKEL SHELL

NUMBER OF SPECIAL CONTACTS
 X's CAN BE DISPLAYED AS TRAILING ZEROS OR LEFT BLANK
 SEE EXAMPLE ORDER CODES FOR EXPLANATION.

RA	2	27.01.11	11106
NAME	ISS.	DATE	C/NOTE
APPROVED:		R. ADDE	
CHECKED:		M.G. PLESTED	
DRAWN:		S. FLOWER	
CUSTOMER REF.:			
ASSEMBLY DRG:			

HARWIN

HARWIN USA TEL: 603 893 5376 FAX: 603 893 5396 mis@harwin.com	HARWIN Europe (UK) TEL: 023 9231 4545 FAX: 023 9231 4590 mis@harwin.co.uk	HARWIN Asia TEL: +65 6 779 4909 FAX: +65 6 779 3868 mis@harwin.com.sg
--	--	--

THIS DRAWING AND ANY INFORMATION OR DESCRIPTIVE MATTER SET OUT HEREON ARE CONFIDENTIAL AND COPYRIGHT PROPERTY OF THE HARWIN GROUP AND MUST NOT BE DISCLOSED, LOANED, COPIED OR USED FOR MANUFACTURING, TENDERING OR FOR ANY OTHER PURPOSE WITHOUT THEIR WRITTEN PERMISSION.

TOLERANCES
 X. = ±1mm
 X.X = ±0.25mm
 X.XX = ±0.10mm
 X.XXX = ±0.01mm
 ANGLES = ±5°
 UNLESS STATED

MATERIAL:
 SEE ABOVE
FINISH: SEE ABOVE
S/AREA: mm²

TITLE: DATAMATE J-TEK FEMALE CRIMP ASSY (SMALL BORE) WITH 10ILOK JACKSCREWS
DRAWING NUMBER: M80-4C1XXXXFC, M80-4C1XXXXFC-00-000-00-000
 SHT 2 OF 2