

High Efficiency LED, Ø 3 mm Tinted Total Diffused Package

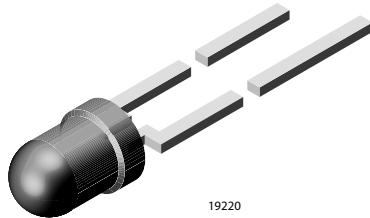

19220

DESCRIPTION

The TLH.46.. series was developed for applications which need a very wide radiation angle like backlighting, general indicating and lighting purposes. It is housed in a 3 mm tinted total diffused plastic package. The wide viewing angle of these devices provides a high on-off contrast.

Several selection types with different luminous intensities are offered. All LEDs are categorized in luminous intensity groups. The green and yellow LEDs are categorized additionally in wavelength groups.

That allows users to assemble LEDs with uniform appearance.

FEATURES

- Choice of three bright colors
- Standard Ø 3 (T-1) package
- Small mechanical tolerances
- Suitable for DC and high peak current
- Very wide viewing angle
- Luminous intensity categorized
- Yellow and green color categorized
- Compliant to RoHS directive 2002/95/EC and in accordance to WEEE 2002/96/EC

RoHS
COMPLIANT

APPLICATIONS

- Status lights
- Off/on indicator
- Background illumination
- Readout lights
- Maintenance lights
- Legend light

PRODUCT GROUP AND PACKAGE DATA

- Product group: LED
- Package: 3 mm
- Product series: standard
- Angle of half intensity: $\pm 60^\circ$

| PARTS TABLE | | |
|----------------|---------------------------|--------------|
| PART | COLOR, LUMINOUS INTENSITY | TECHNOLOGY |
| TLHR4600 | Red, $I_V > 1$ mcd | GaAsP on GaP |
| TLHR4605 | Red, $I_V > 2.5$ mcd | GaAsP on GaP |
| TLHR4605-MS12Z | Red, $I_V > 2.5$ mcd | GaAsP on GaP |
| TLHY4600 | Yellow, $I_V > 0.63$ mcd | GaAsP on GaP |
| TLHY4600-AS12 | Yellow, $I_V > 0.63$ mcd | GaAsP on GaP |
| TLHY4601 | Yellow, $I_V > 1$ mcd | GaAsP on GaP |
| TLHY4605 | Yellow, $I_V > 2.5$ mcd | GaAsP on GaP |
| TLHG4600 | Green, $I_V > 1$ mcd | GaP on GaP |
| TLHG4605 | Green, $I_V > 4$ mcd | GaP on GaP |
| TLHG4605-AS12Z | Green, $I_V > 4$ mcd | GaP on GaP |
| TLHG4605-MS21Z | Green, $I_V > 4$ mcd | GaP on GaP |

| ABSOLUTE MAXIMUM RATINGS ¹⁾ TLHR460. , TLHY460. , TLHG460. | | | | |
|---|---|------------|---------------|------------------|
| PARAMETER | TEST CONDITION | SYMBOL | VALUE | UNIT |
| Reverse voltage | | V_R | 6 | V |
| DC Forward current | $T_{amb} \leq 60\text{ }^\circ\text{C}$ | I_F | 30 | mA |
| Surge forward current | $t_p \leq 10\text{ }\mu\text{s}$ | I_{FSM} | 1 | A |
| Power dissipation | $T_{amb} \leq 60\text{ }^\circ\text{C}$ | P_V | 100 | mW |
| Junction temperature | | T_j | 100 | $^\circ\text{C}$ |
| Operating temperature range | | T_{amb} | - 20 to + 100 | $^\circ\text{C}$ |
| Storage temperature range | | T_{stg} | - 55 to + 100 | $^\circ\text{C}$ |
| Soldering temperature | $t \leq 5\text{ s}$, 2 mm from body | T_{sd} | 260 | $^\circ\text{C}$ |
| Thermal resistance junction/ambient | | R_{thJA} | 400 | K/W |

Note:

¹⁾ $T_{amb} = 25\text{ }^\circ\text{C}$, unless otherwise specified

| OPTICAL AND ELECTRICAL CHARACTERISTICS ¹⁾ TLHR460., RED | | | | | | | |
|--|--------------------------------|----------|-------------|------|----------|------|------|
| PARAMETER | TEST CONDITION | PART | SYMBOL | MIN. | TYP. | MAX. | UNIT |
| Luminous intensity ²⁾ | $I_F = 10\text{ mA}$ | TLHR4600 | I_V | 1 | 4 | | mcd |
| | | TLHR4605 | I_V | 2.5 | 6 | | mcd |
| Dominant wavelength | $I_F = 10\text{ mA}$ | | λ_d | 612 | | 625 | nm |
| Peak wavelength | $I_F = 10\text{ mA}$ | | λ_p | | 635 | | nm |
| Angle of half intensity | $I_F = 10\text{ mA}$ | | φ | | ± 60 | | deg |
| Forward voltage | $I_F = 20\text{ mA}$ | | V_F | | 2 | 3 | V |
| Reverse voltage | $I_R = 10\text{ }\mu\text{A}$ | | V_R | 6 | 15 | | V |
| Junction capacitance | $V_R = 0$, $f = 1\text{ MHz}$ | | C_j | | 50 | | pF |

Note:

¹⁾ $T_{amb} = 25\text{ }^\circ\text{C}$, unless otherwise specified

²⁾ In one packing unit $I_{Vmin.}/I_{Vmax.} \leq 0.5$

| OPTICAL AND ELECTRICAL CHARACTERISTICS ¹⁾ TLHY460., YELLOW | | | | | | | |
|---|--------------------------------|----------|-------------|------|----------|------|------|
| PARAMETER | TEST CONDITION | PART | SYMBOL | MIN. | TYP. | MAX. | UNIT |
| Luminous intensity ²⁾ | $I_F = 10\text{ mA}$ | TLHY4600 | I_V | 0.63 | 3.5 | | mcd |
| | | TLHY4601 | I_V | 1 | 4 | | mcd |
| | | TLHY4605 | I_V | 2.5 | 5 | | mcd |
| Dominant wavelength | $I_F = 10\text{ mA}$ | | λ_d | 581 | | 594 | nm |
| Peak wavelength | $I_F = 10\text{ mA}$ | | λ_p | | 585 | | nm |
| Angle of half intensity | $I_F = 10\text{ mA}$ | | φ | | ± 60 | | deg |
| Forward voltage | $I_F = 20\text{ mA}$ | | V_F | | 2.4 | 3 | V |
| Reverse voltage | $I_R = 10\text{ }\mu\text{A}$ | | V_R | 6 | 15 | | V |
| Junction capacitance | $V_R = 0$, $f = 1\text{ MHz}$ | | C_j | | 50 | | pF |

Note:

¹⁾ $T_{amb} = 25\text{ }^\circ\text{C}$, unless otherwise specified

²⁾ In one packing unit $I_{Vmin.}/I_{Vmax.} \leq 0.5$

| OPTICAL AND ELECTRICAL CHARACTERISTICS ¹⁾ TLHG460., GREEN | | | | | | | |
|---|------------------------------|----------|-------------|------|----------|------|------|
| PARAMETER | TEST CONDITION | PART | SYMBOL | MIN. | TYP. | MAX. | UNIT |
| Luminous intensity ²⁾ | $I_F = 10 \text{ mA}$ | TLHG4600 | I_V | 1 | 4 | | mcd |
| | | TLHG4605 | I_V | 4 | 6 | | mcd |
| Dominant wavelength | $I_F = 10 \text{ mA}$ | | λ_d | 562 | | 575 | nm |
| Peak wavelength | $I_F = 10 \text{ mA}$ | | λ_p | | 565 | | nm |
| Angle of half intensity | $I_F = 10 \text{ mA}$ | | ϕ | | ± 60 | | deg |
| Forward voltage | $I_F = 20 \text{ mA}$ | | V_F | | 2.4 | 3 | V |
| Reverse voltage | $I_R = 10 \mu\text{A}$ | | V_R | 6 | 15 | | V |
| Junction capacitance | $V_R = 0, f = 1 \text{ MHz}$ | | C_j | | 50 | | pF |

Note:

¹⁾ $T_{\text{amb}} = 25 \text{ }^\circ\text{C}$, unless otherwise specified

²⁾ In one packing unit $I_{V\text{min.}}/I_{V\text{max.}} \leq 0.5$

| LUMINOUS INTENSITY CLASSIFICATION | | |
|--|-----------------------|------|
| GROUP | LIGHT INTENSITY (mcd) | |
| STANDARD | MIN. | MAX. |
| K | 0.63 | 1.25 |
| L | 1 | 2 |
| M | 1.6 | 3.2 |
| N | 2.5 | 5 |
| P | 4 | 8 |
| Q | 6.3 | 12.5 |
| R | 10 | 20 |
| S | 16 | 32 |
| T | 25 | 50 |
| U | 40 | 80 |

Note:

Luminous intensity is tested at a current pulse duration of 25 ms and an accuracy of $\pm 11 \%$.

The above type numbers represent the order groups which include only a few brightness groups. Only one group will be shipped on each bag (there will be no mixing of two groups on each bag).

In order to ensure availability, single brightness groups will not be orderable.

In a similar manner for colors where wavelength groups are measured and binned, single wavelength groups will be shipped on any one bag. In order to ensure availability, single wavelength groups will not be orderable.

TYPICAL CHARACTERISTICS

$T_{\text{amb}} = 25 \text{ }^\circ\text{C}$, unless otherwise specified

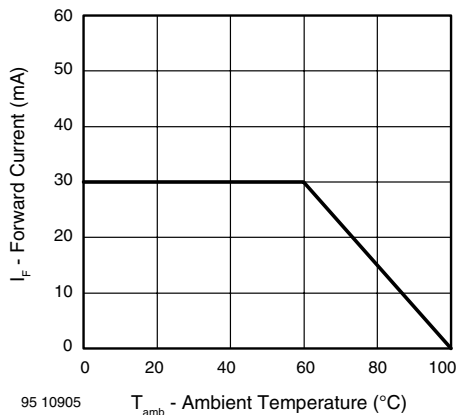

Figure 1. Forward Current vs. Ambient Temperature for InGaN

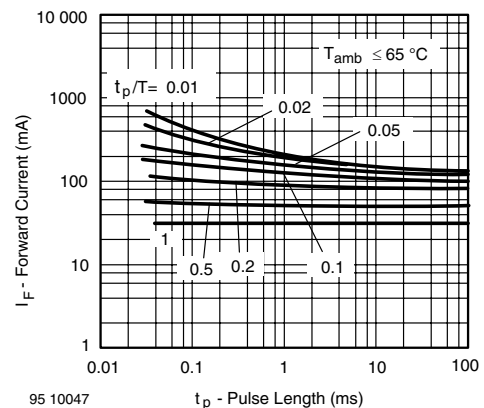

Figure 2. Forward Current vs. Pulse Length

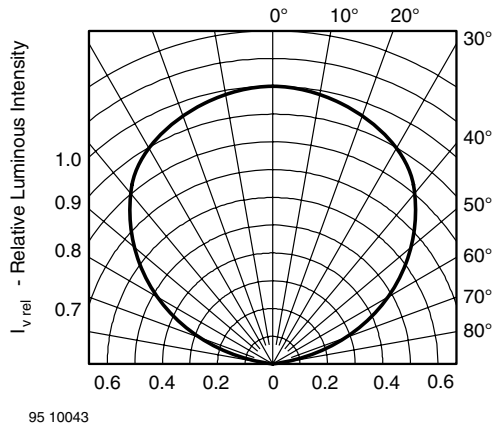

Figure 3. Rel. Luminous Intensity vs. Angular Displacement

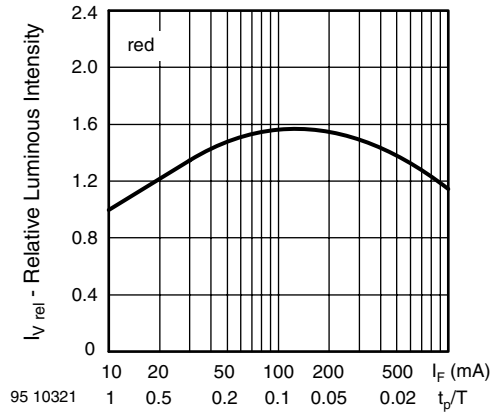

Figure 6. Rel. Lumin. Intensity vs. Forw. Current/Duty Cycle

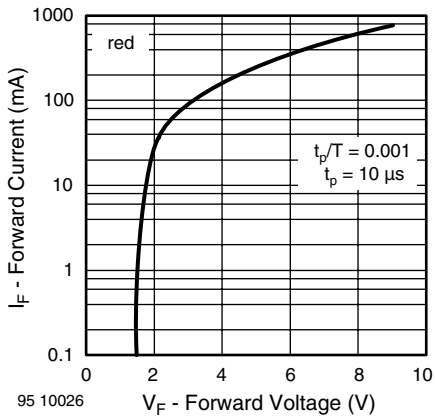

Figure 4. Forward Current vs. Forward Voltage

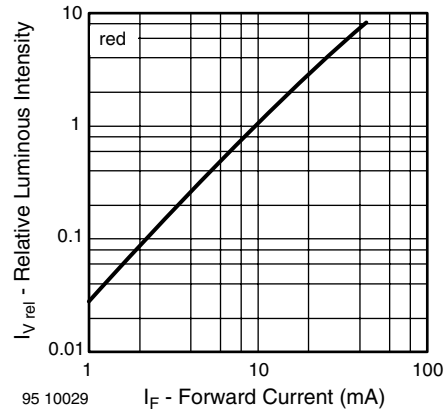

Figure 7. Relative Luminous Intensity vs. Forward Current

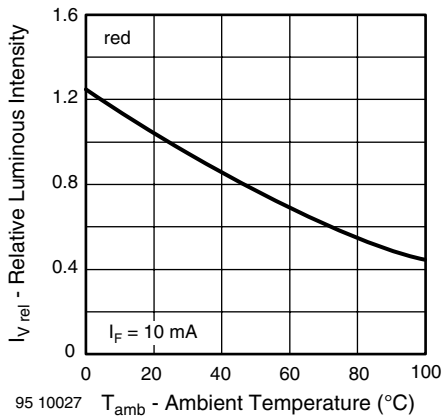

Figure 5. Rel. Luminous Intensity vs. Ambient Temperature

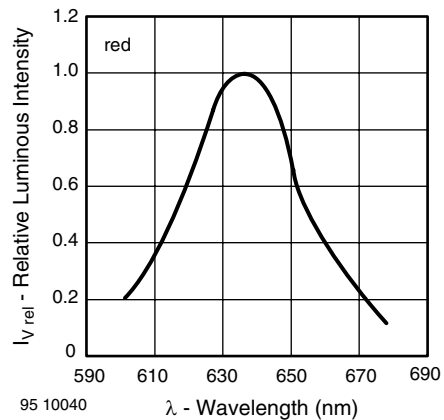

Figure 8. Relative Intensity vs. Wavelength

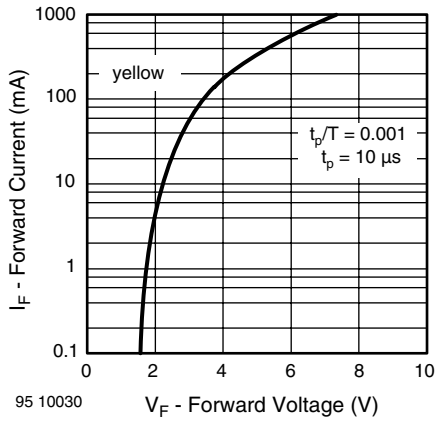

Figure 9. Forward Current vs. Forward Voltage

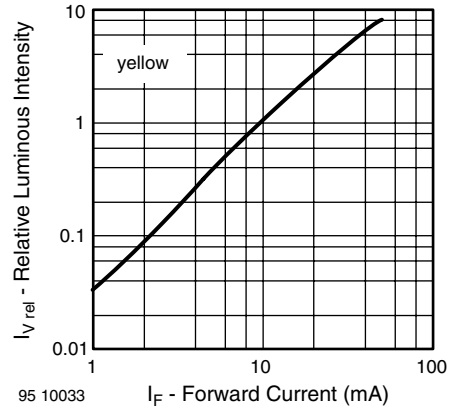

Figure 12. Relative Luminous Intensity vs. Forward Current

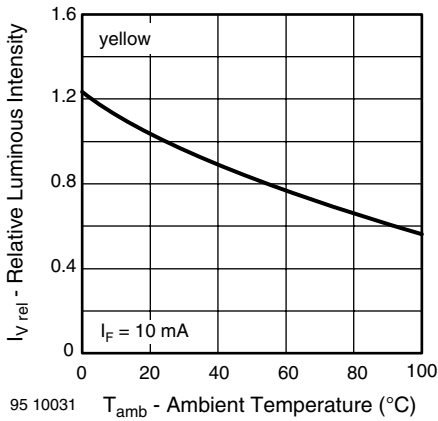

Figure 10. Rel. Luminous Intensity vs. Ambient Temperature

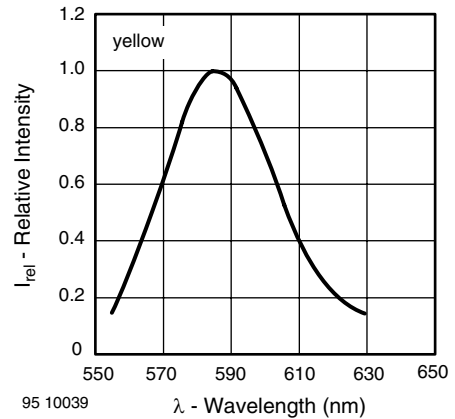

Figure 13. Relative Intensity vs. Wavelength

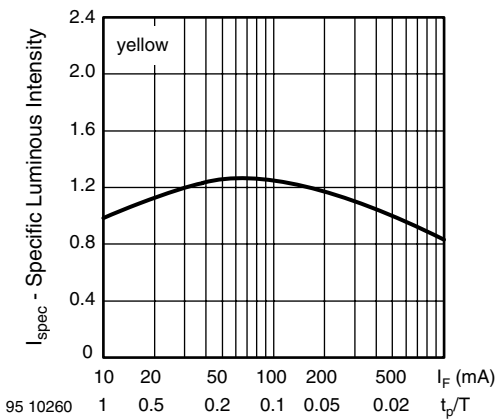

Figure 11. Rel. Lumin. Intensity vs. Forw. Current/Duty Cycle

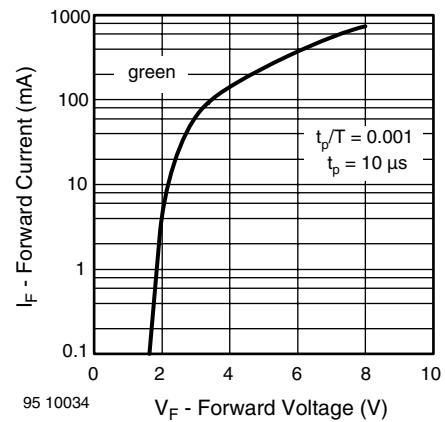

Figure 14. Forward Current vs. Forward Voltage

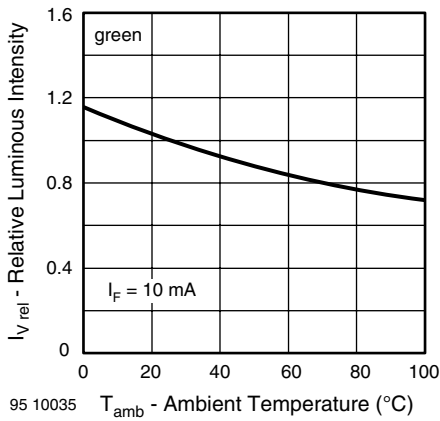

Figure 15. Rel. Luminous Intensity vs. Ambient Temperature

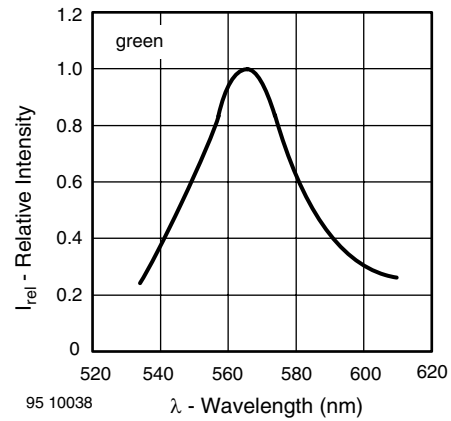

Figure 18. Relative Intensity vs. Wavelength

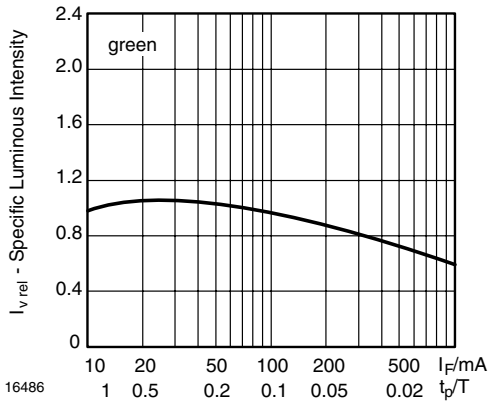

Figure 16. Rel. Lumin. Intensity vs. Forw. Current/Duty Cycle

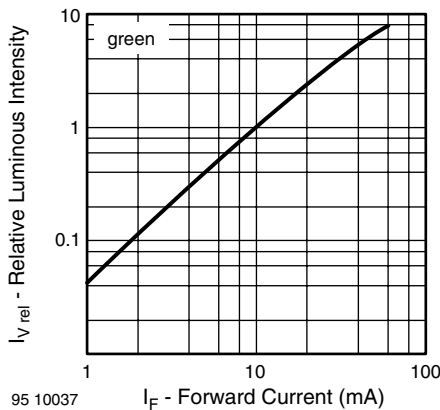
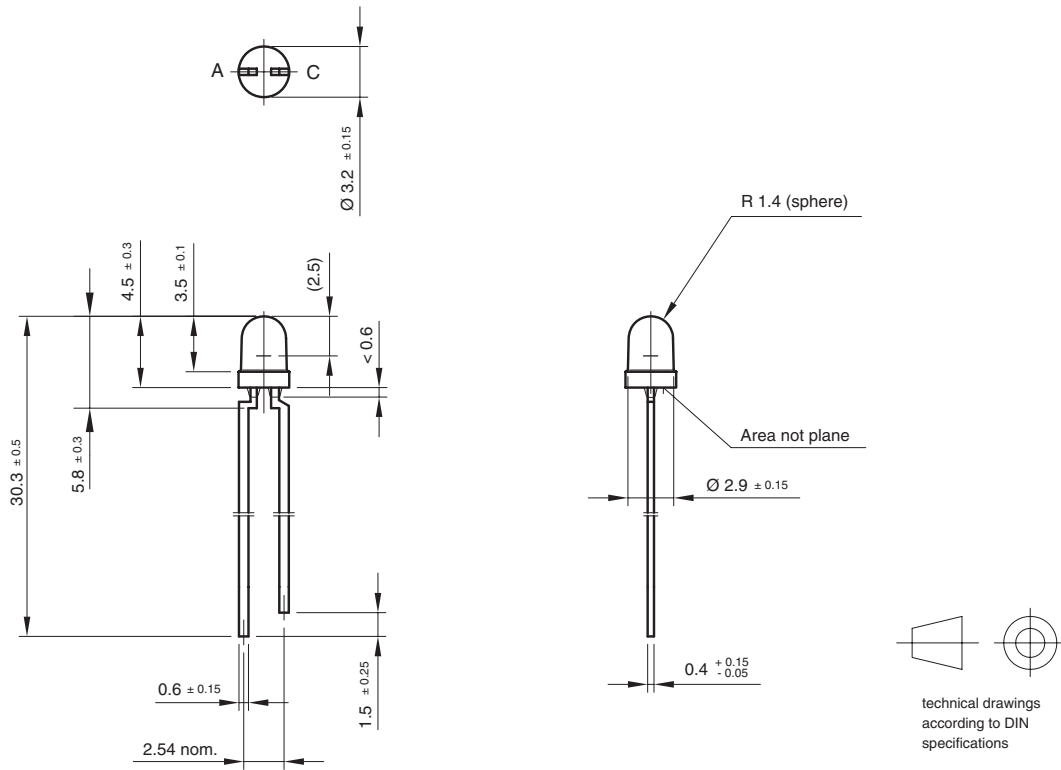

Figure 17. Relative Luminous Intensity vs. Forward Current



PACKAGE DIMENSIONS in millimeters



Drawing-No.: 6.544-5255.01-4
Issue: 7; 25.09.08
95 10913

TAPE

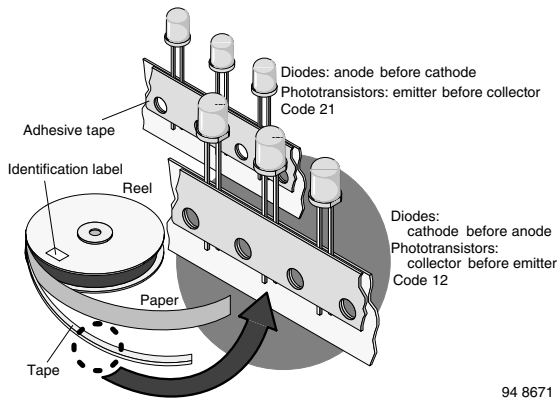

Figure 19. LED in Tape

94 8671

AMMOPACK

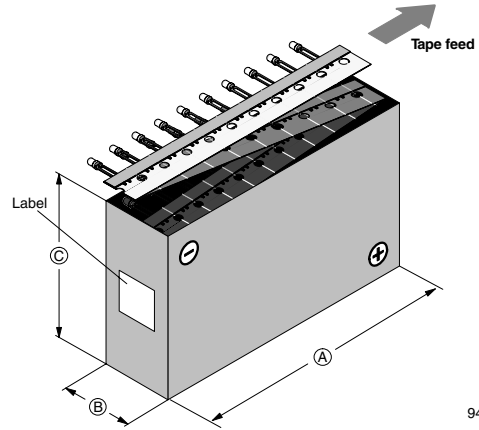
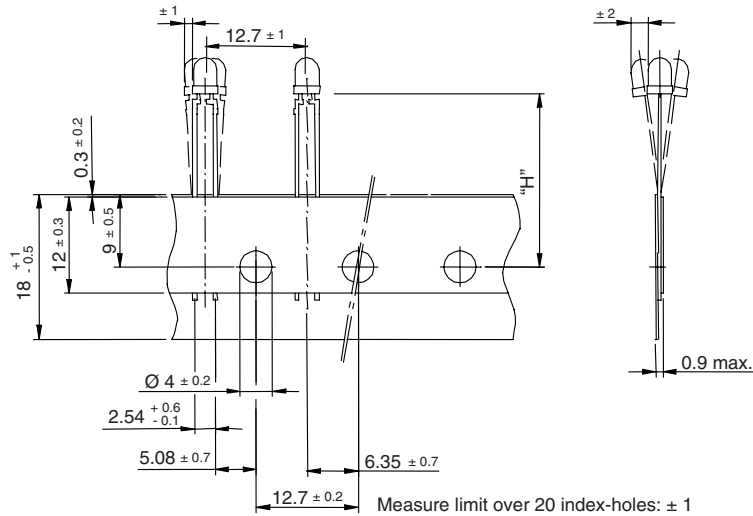

Figure 20. Tape Direction

94 8667-1

Note:
AS12Z and AS21Z still valid for already existing types BUT NOT FOR NEW DESIGN

TAPE DIMENSIONS in millimeters



| | |
|---------------|---------------------------|
| Quantity per: | Reel (Mat. - No. 1764) |
| | 2000 |

94 8171

| | |
|--------|-------------------|
| Option | Dim. "H" ± 0.5 mm |
| AS | 17.3 |
| MS | 25.5 |



Disclaimer

All product specifications and data are subject to change without notice.

Vishay Intertechnology, Inc., its affiliates, agents, and employees, and all persons acting on its or their behalf (collectively, "Vishay"), disclaim any and all liability for any errors, inaccuracies or incompleteness contained herein or in any other disclosure relating to any product.

Vishay disclaims any and all liability arising out of the use or application of any product described herein or of any information provided herein to the maximum extent permitted by law. The product specifications do not expand or otherwise modify Vishay's terms and conditions of purchase, including but not limited to the warranty expressed therein, which apply to these products.

No license, express or implied, by estoppel or otherwise, to any intellectual property rights is granted by this document or by any conduct of Vishay.

The products shown herein are not designed for use in medical, life-saving, or life-sustaining applications unless otherwise expressly indicated. Customers using or selling Vishay products not expressly indicated for use in such applications do so entirely at their own risk and agree to fully indemnify Vishay for any damages arising or resulting from such use or sale. Please contact authorized Vishay personnel to obtain written terms and conditions regarding products designed for such applications.

Product names and markings noted herein may be trademarks of their respective owners.