

# HS 7541

## 12-Bit Monolithic Multiplying DAC

### FEATURES

- 12-Bit Linearity
- 2 and 4 Quadrant Multiplication
- 0.5 ppm/°C Gain Error Tempco
- Single Power Supply Operation
- Plug-In Replacement for AD7541 and MP7621
- MIL- versions to MIL-STD-883 Rev. C Available

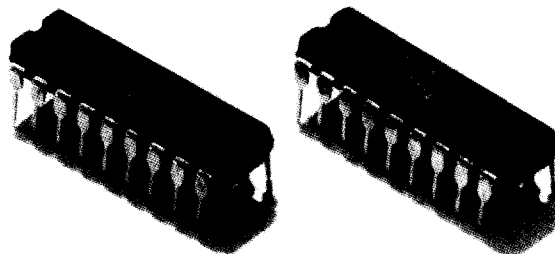

### DESCRIPTION

The HS 7541 is a 12-Bit monolithic digital-to-analog converter featuring a single high-density CMOS chip that includes an advanced resistor network. Linearity of 0.01% is achieved without laser trimming, eliminating a costly manufacturing step while improving stability and reliability.

HS 7541 consists of a highly stable thin film R-2R ladder network and twelve CMOS current switches on a monolithic chip. The "ON" resistances of the switches are binarily scaled, so the voltage drop across each switch is identical. This is essential in maintaining the accuracy of the binarily weighted current division performed by the ladder network. The internal feedback resistor used in the output's current-to-voltage conversion operation is matched to the R-2R

ladder and scaled for a maximum gain error of 0.3% F.S.R. Further, special thermal compensation reduces the gain error drift over temperature.

The HS 7541 is a pin and functional equivalent to the AD7541 and MP7621. It meets or exceeds the performance of these devices, with improved supply rejection, improved temperature stability, lower output glitching and lower variation in linearity and gain error with  $V_{DD}$ .

### FUNCTIONAL DIAGRAM

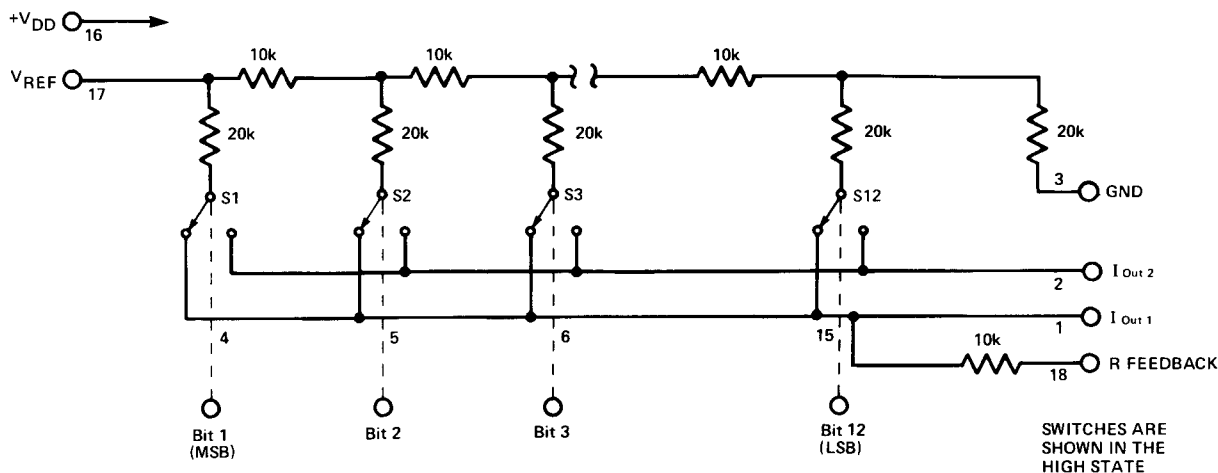

# SPECIFICATIONS

( $V_{DD} = +15V$ ,  $V_{REF} = +10V$  unless otherwise noted)

PARAMETER	$T_A = +25^\circ C$	$T_{min} - T_{max}$	Test Condition
<b>TYPE</b>	Multiplying		
<b>DIGITAL INPUT</b>			
Resolution	12-Bits		
2-Quad. Unipolar Coding	Binary		
4-Quad. Bipolar Coding	Offset Binary		
Logic Compatibility	TTL, CMOS		
Logic Thresholds			
$V_{INH}$	2.4V (min)	2.4V (min)	
$V_{INL}$	0.8V (max)	0.8V (max)	
Input Leakage Current	$\pm 1 \mu A$ (max)	$\pm 1 \mu A$ (max)	$V_{IN} = 0$ or $+15V$
<b>REFERENCE INPUT</b>			
Voltage Range	$\pm 25V$ (max)	$\pm 25V$ (max)	
Input Impedance	$5k \Omega$ (min), $20k \Omega$ (max)	$5k \Omega$ (min), $20k \Omega$ (max)	
<b>ANALOG INPUT</b>			
Output Current <sup>1</sup>	1mA (nominal)		
Output Capacity			
$C_{out 1}$	200pF (max)	200pF (max)	Digital Inputs = $V_{INH}$
$C_{out 2}$	60pF (max)	60pF (max)	Digital Inputs = $V_{INL}$
$C_{out 1}$	60pF (max)	60pF (max)	
$C_{out 2}$	200pF (max)	200pF (max)	
<b>STATIC PERFORMANCE</b>			
Linearity <sup>1</sup>			
HS 7541-1	$\pm 0.024\%$ F.S.R. (max)	$\pm 0.024\%$ F.S.R. (max)	$V_{out 1} = V_{out 2} = 0V$
HS 7541-2	$\pm 0.012\%$ F.S.R. (max)	$\pm 0.012\%$ F.S.R. (max)	$V_{out 1} = V_{out 2} = 0V$
Gain Accuracy <sup>2</sup>	$\pm 0.3\%$ F.S.R. (max)	$\pm 0.4\%$ F.S.R. (max)	
Output Leakage	$\pm 50nA$ (max)	$\pm 200nA$ (max)	$V_{REF} = \pm 10V$
<b>DYNAMIC PERFORMANCE</b>			
Output Current Settling to 0.01%	1 $\mu s$ (max)	1 $\mu s$ (max)	
Reference Feedthrough Error ( $V_{REF} = 20V_{pp}$ @ 10kHz)	1mV <sub>pp</sub> (max)	1mV <sub>pp</sub> (max)	
<b>STABILITY</b>			
Scale Factor	$\pm 2ppm$ F.S.R./ $^\circ C$ (max)	$\pm 2ppm$ F.S.R./ $^\circ C$ (max)	
Linearity	$\pm 0.2ppm$ F.S.R./ $^\circ C$ (max)	$\pm 0.2ppm$ F.S.R./ $^\circ C$ (max)	
<b>POWER SUPPLY</b>			
Voltage ( $V_{DD}$ )			
Nominal	+15V		
Range	+5V to +16V	+5V to +16V	Accuracy guaranteed at +15V
Current - Nominal	2mA	2mA (max)	All inputs high or low
Rejection Ratio (14.5V to 15.5V)	$\pm 0.005\%/%$ (max)	$\pm 0.005\%/%$ (max)	$V_{DD} = 14.5V$ to $15.5V$
<b>TEMPERATURE RANGE</b>			
Operating			
7541C-1,-2		0 $^\circ C$ to +70 $^\circ C$	
7541B-1,-2		-55 $^\circ C$ to +125 $^\circ C$	
Storage		-65 $^\circ C$ to +150 $^\circ C$	

## NOTES:

- The HS 7541 is designed to be used only in those applications where the current output is at virtual ground, i.e., the summing junction of an opamp in the inverting mode. The internal feedback resistor must be used to achieve specified performance.
- Using the internal feedback resistor.

## CAUTION

Do not apply voltages higher than  $V_{DD}$  or less than GND potential on any terminal except  $V_{REF}$ .

## MECHANICAL

Case Style 18 Pin DIP  
 7541C-1,-2 plastic  
 7541B-1,-2 ceramic, side braze

Dimensions

7541C-1,-2

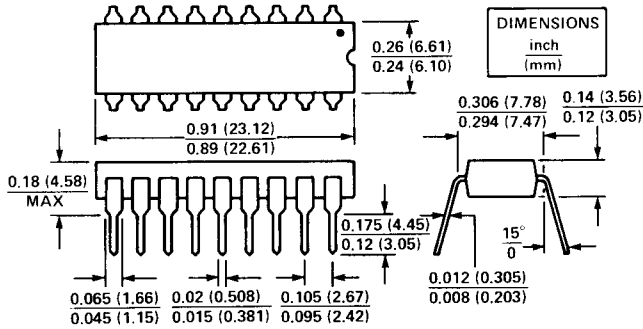

7541E-1,-2  
 7541B-1,-2

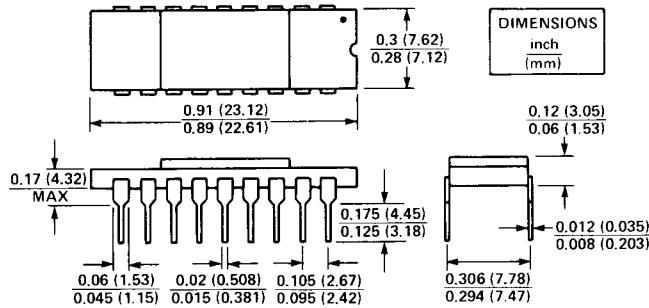

Pin Assignments

PIN	FUNCTION	PIN	FUNCTION
1	OUT 1	18	R FEEDBACK
2	OUT 2	19	V REF
3	GND	16	+V <sub>DD</sub>
4	Bit 1 (MSB)	15	Bit 12 (LSB)
5	Bit 2	14	Bit 11
6	Bit 3	13	Bit 10
7	Bit 4	12	Bit 9
8	Bit 5	11	Bit 8
9	Bit 6	10	Bit 7

## APPLICATIONS INFORMATION

UNIPOLAR OPERATION (2-Quadrant Multiplication)

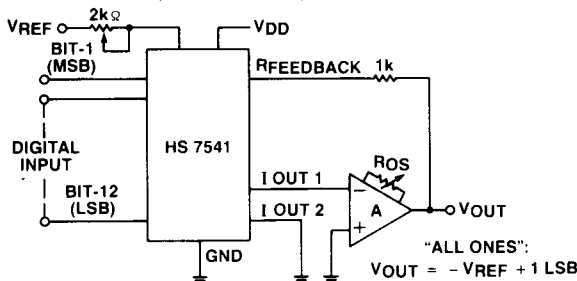

NOTE: To maintain specified HS 7541 linearity, the external amplifier (A) must be zeroed. Apply an ALL "ZEROS" digital input and adjust ROS for  $V_{OUT} = 0 \pm 1mV$ .

BIPOLAR OPERATION (4-Quadrant Multiplication)

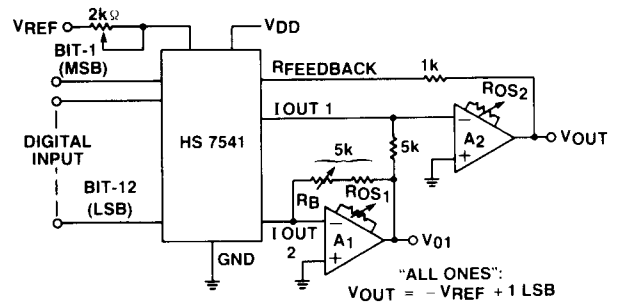

NOTE: To maintain specified HS 7541 linearity, external amplifiers (A<sub>1</sub> and A<sub>2</sub>) must be zeroed. With a digital input of 10...0 and VREF set to zero:  
 a) Set ROS<sub>1</sub> for V<sub>O1</sub> = 0  
 b) Set ROS<sub>2</sub> for V<sub>OUT</sub> = 0  
 c) Set VREF to +10V and adjust R<sub>B</sub> for V<sub>OUT</sub> to be 0 Volts.

UNIPOLAR OPERATION  
 Transfer Characteristics

BINARY INPUT	ANALOG OUTPUT
1 1 1 ... 1 1 1	$-V_{REF} \cdot \frac{4095}{4096}$
1 0 0 ... 0 0 1	$-V_{REF} \cdot \frac{2049}{4096}$
1 0 0 ... 0 0 0	$-V_{REF} \cdot \frac{2048}{4096}$
0 1 1 ... 1 1 1	$-V_{REF} \cdot \frac{2047}{4096}$
0 0 0 ... 0 0 1	$-V_{REF} \cdot \frac{1}{4096}$
0 0 0 ... 0 0 0	0

BIPOLAR OPERATION  
 Transfer Characteristics

OFFSET BINARY INPUT	ANALOG OUTPUT
1 1 1 ... 1 1 1	$-V_{REF} \cdot \frac{2047}{2048}$
1 0 0 ... 0 0 1	$-V_{REF} \cdot \frac{1}{2048}$
1 0 0 ... 0 0 0	0
0 1 1 ... 1 1 1	$V_{REF} \cdot \frac{1}{2048}$
0 0 0 ... 0 0 1	$V_{REF} \cdot \frac{2047}{2048}$
0 0 0 ... 0 0 0	VREF

$$\text{Formula: } V_{OUT} = -V_{REF} \cdot \frac{N}{4096}$$

where N represents the code applied to the DAC

$$\text{Formula: } V_{OUT} = -V_{REF} \cdot \frac{(N-2048)}{2048}$$

where N represents the code applied to the DAC

UNIPOLAR OPERATION

The connections required for digital unipolar operation are shown above. The reference voltage VREF may be either positive or negative. The 2kΩ potentiometer in the VREF line and the 1kΩ resistor in the feedback loop are optional and are only needed when the gain error must be trimmed to less than 0.3% F.S.R. They should track each other to better than 0.1%, but don't have to track 7541's internal network resistors.

BIPOLAR OPERATION

The digital input is offset binary coded and produces an output according to the table above. As with unipolar operation, the gain trim resistors can be omitted in applications accepting a gain error of 0.3% (max).

AMPLIFIER SELECTION

HS 7541 will operate with almost all types of operational amplifiers. However, if certain high speed opamps are selected, the output terminals OUT 1 and OUT 2 should be clamped to ground using Schottky diodes (HP 5082-2811 or equivalent) to prevent OUT 1 or OUT 2 from going negative.

The output resistance of the 7541 varies with the digital input code. The error effect on the output voltage is  $2/3 V_{OS}$ . Therefore, the offset voltage V<sub>OS</sub> of the external opamps must be nulled.

For the same reason, the usual bias current compensation resistor in the amplifiers non-inverting input terminal must not be used. Instead, the amplifier should have a low bias current over the operating temperature range and it should not exceed 75mA.

## TYPICAL PERFORMANCE CHARACTERISTICS

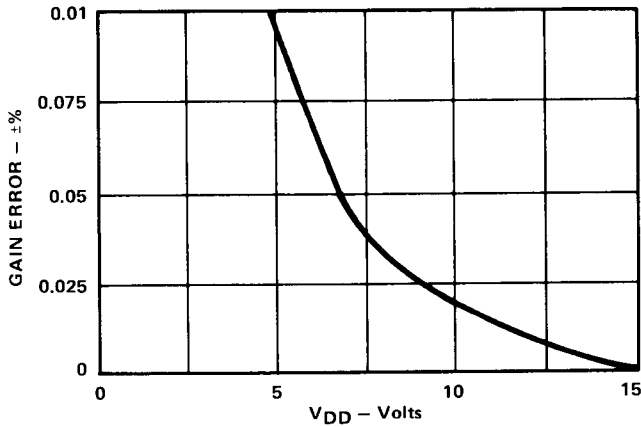

Figure 1. Gain Error vs. Supply Voltage

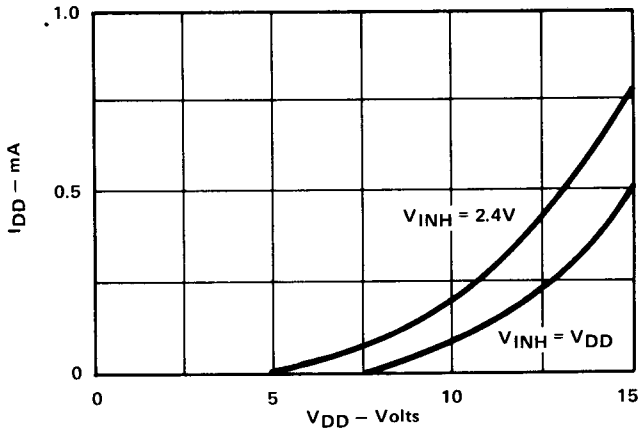

Figure 2. Supply Current vs. Supply Voltage

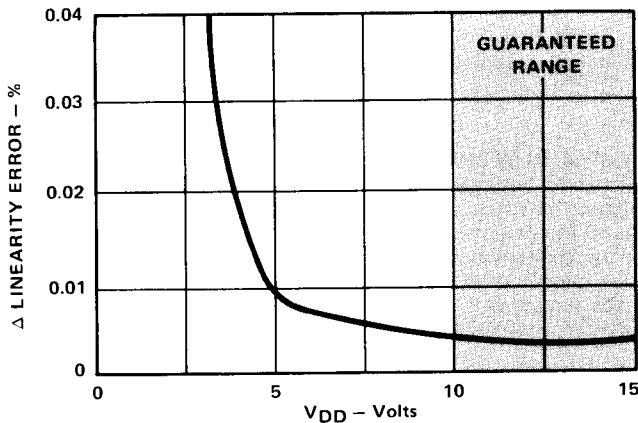

Figure 3. Linearity Error vs. Supply Voltage Typ.

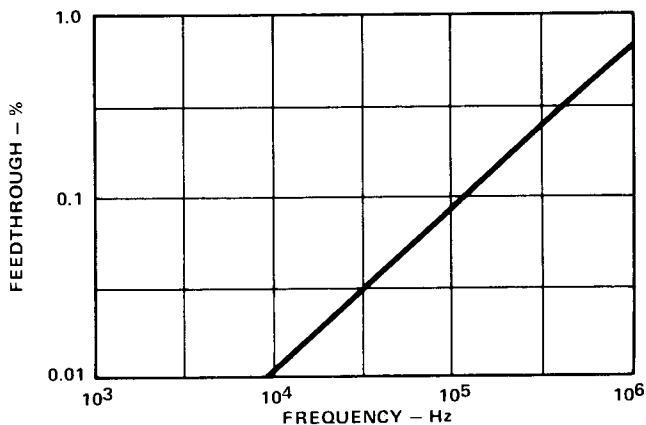

Figure 4. Feedthrough Error vs. Frequency

## APPLICATION HINTS

Linearity depends upon the potential at  $I_{out 1}$  and  $I_{out 2}$  (pin 1 and pin 2) being exactly equal to GND (pin 3) and the output amplifier's non-inverting (+) input. Careful PC board layout and adjustment and selection of the amplifier's offset voltage and bias current are necessary.

The input structures of some high speed operational amplifiers can attempt to draw substantial current during switch-on. Schottky diodes should be used in these circumstances to prevent the absolute maximum rating for  $V_{out 1}$  and  $V_{out 2}$  being exceeded.

The power supply should be carefully checked for noise, which would affect performance, and overshoot which could damage the device.

Unused digital inputs must always be grounded or taken to  $V_{DD}$  to ensure correct operation. Particular care should be taken when digital inputs are routed to another PC card. It is recommended that inputs open-circuited when PC cards are disconnected be taken to  $V_{DD}$  or GND via high value ( $1M\Omega$ ) resistors to prevent the accumulation of static charges.

## HIGH-RELIABILITY PROCESSING

The MIL-temperature ( $-55^{\circ}C$  to  $+125^{\circ}C$  versions of HS 7541 (i.e. HS 7541B-1 and HS 7541B-2) are manufactured and processed to the requirements of MIL-STD-883B. All units undergo a screening and burn-in in accordance with METHOD 5004. For details contact the factory.

**CAUTION:** ESD (Electro-Static Discharge) sensitive device. Permanent damage may occur when unconnected devices are subjected to high energy electrostatic fields. Unused devices must be stored in conductive foam or shunts. Protective foam should be discharged to the destination socket before devices are removed. Devices should be handled at static safe workstations only. Unused digital inputs must be grounded or tied to the logic supply voltage. Unless otherwise noted, the supply voltage at any digital input should never exceed the supply voltage by more than 0.5 volts or go below  $-0.5$  volts. If this condition cannot be maintained, limit input current on digital inputs by using series resistors or contact Hybrid Systems for technical assistance.

## ORDERING INFORMATION

MODEL	DESCRIPTION
HS 7541C-1	$\pm 0.024\%$ Linearity, 0 to $+70^{\circ}C$
HS 7541C-2	$\pm 0.012\%$ Linearity, 0 to $+70^{\circ}C$
HS 7541B-1	$\pm 0.024\%$ Linearity, $-55^{\circ}C$ to $+125^{\circ}C$
HS 7541B-2	$\pm 0.012\%$ Linearity, $-55^{\circ}C$ to $+125^{\circ}C$

Specifications subject to change without notice.