

MC10H334

Quad Bus Driver/Receiver with Transmit and Receiver Latches

The MC10H334 is a Quad Bus Driver/Receiver with transmit and receiver latches. When disabled, (\overline{OE} = high) the bus outputs will fall to -2.0 V. Data to be transmitted or received is passed through its respective latch when the respective latch enable (\overline{DLE} and \overline{RLE}) is at a low level. Information is latched on the positive transition of \overline{DLE} and \overline{RLE} . The parameters specified are with $25\ \Omega$ loading on the bus drivers and $50\ \Omega$ loads on the receivers.

- Propagation Delay, 1.6 ns Typical Data-to-Output
- Improved Noise Margin 150 mV (Over Operating Voltage and Temperature Range)
- Voltage Compensated
- MECL 10K-Compatible

DIP & PLCC PIN ASSIGNMENT

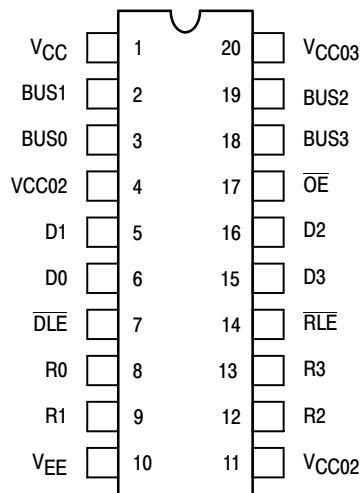

Pin assignment is for Dual-in-Line Package.
For PLCC pin assignment, see the Pin Conversion Tables on page 18 of the ON Semiconductor MECL Data Book (DL122/D).

NOTE:

Each MECL 10H series circuit has been designed to meet the dc specifications shown in the test table, after thermal equilibrium has been established. The circuit is in a test socket or mounted on a printed circuit board and transverse air flow greater than 500 l/fpm is maintained. Receiver outputs are terminated through a 50-ohm resistor to -2.0 volts dc. Bus outputs are terminated through a 25-ohm resistor to -2.0 volts dc.



ON Semiconductor

<http://onsemi.com>

MARKING DIAGRAMS

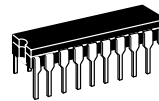

CDIP-20
L SUFFIX
CASE 732

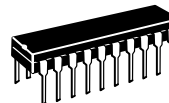
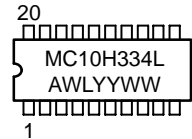

PDIP-20
P SUFFIX
CASE 738

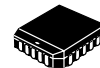
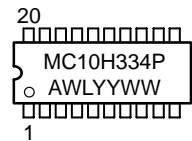

PLCC-20
FN SUFFIX
CASE 775

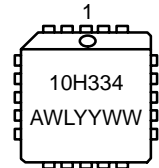

A = Assembly Location
WL = Wafer Lot
YY = Year
WW = Work Week

ORDERING INFORMATION

Device	Package	Shipping
MC10H334L	CDIP-20	18 Units/Rail
MC10H334P	PDIP-20	18 Units/Rail
MC10H334FN	PLCC-20	46 Units/Rail

MC10H334

MAXIMUM RATINGS

Symbol	Characteristic	Rating	Unit
V_{EE}	Power Supply ($V_{CC} = 0$)	-8.0 to 0	Vdc
V_I	Input Voltage ($V_{CC} = 0$)	0 to V_{EE}	Vdc
I_{out}	Output Current – Continuous – Surge	50 100	mA
T_A	Operating Temperature Range	0 to +75	°C
T_{stg}	Storage Temperature Range – Plastic – Ceramic	-55 to +150 -55 to +165	°C °C

ELECTRICAL CHARACTERISTICS ($V_{EE} = -5.2\text{ V} \pm 5\%$) (See Note)

Symbol	Characteristic	0°		25°		75°		Unit
		Min	Max	Min	Max	Min	Max	
I_E	Power Supply Current	-	161	-	161	-	161	mA
I_{inH}	Input Current High	-	397	-	273	-	273	μA
	Pins 5,6,15,16	-	460	-	297	-	297	
	Pins 7,14	-	520	-	357	-	357	
	Pin 17	-		-		-		
I_{inL}	Input Current Low	0.5	-	0.5	-	0.3	-	μA
V_{OH}	High Output Voltage	-1.02	-0.84	-0.98	-0.81	-0.92	-0.735	Vdc
V_{OL}	Low Output Voltage	-1.95	-1.63	-1.95	-1.63	-1.95	-1.60	Vdc
V_{IH}	High Input Voltage	-1.17	-0.84	-1.13	-0.81	-1.07	-0.735	Vdc
V_{IL}	Low Input Voltage	-1.95	-1.48	-1.95	-1.48	-1.95	-1.45	Vdc

AC PARAMETERS

t_{pd}	Propagation Delay							ns
	Data-to-Bus Output	0.5	2.5	0.5	2.5	0.5	2.5	
	\overline{DLE} -to-Bus Output	1.0	2.7	1.0	2.7	1.0	2.7	
	\overline{OE} -to-Bus Output	0.5	2.5	0.5	2.5	0.5	2.5	
	Bus-to-R0	0.5	1.9	0.5	1.9	0.5	1.9	
	\overline{RLE} -to-R0	0.5	2.1	0.5	2.1	0.5	2.1	
	Data-to-Receiver R0	1.0	3.8	1.0	3.8	1.0	3.8	
t_r	Rise Time	0.5	2.2	0.5	2.2	0.5	2.2	ns
t_f	Fall Time	0.5	2.2	0.5	2.2	0.5	2.2	ns

MC10H334

LOGIC DIAGRAM

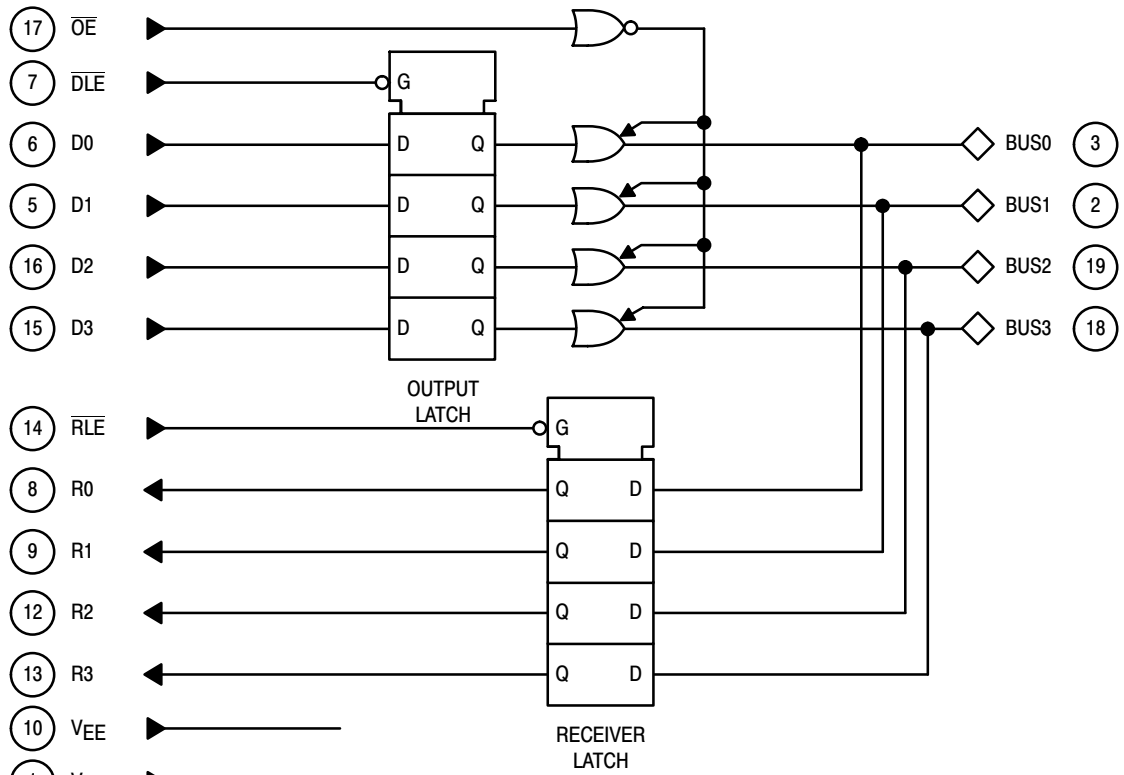

DRIVER TRUTH TABLE

D	\overline{DLE}	\overline{OE}	Bus _{n+1}
X	X	H	-2.0 V
D	L	L	D
X	H	L	Bus _n

RECEIVER TRUTH TABLE

Bus	\overline{RLE}	R _{n+1}
Bus	L	Bus
X	H	R _n