

DO NOT SCALE FROM THIS PRINT

BSW-1XX-X4-X-X-X

No OF POSITIONS  
-02 THRU -36 (PER ROW)  
LEAD STYLE  
-04: C-8-5-X (STANDARD I/W FORCES)  
-24: C-17-5-X (LOW I/W FORCES)  
OPTION  
-S: STANDOFFS (USE BSW-36-X-S, SEE TABLE 1)  
ROW SPECIFICATION  
SEE TABLE 1

PLATING SPECIFICATION

-G: 20µ" GOLD IN CONTACT AREA, 3µ" GOLD ON TAIL  
-T: MATTE TIN CONTACT AND TAIL (STYLE -04 ONLY)  
-S: 30µ" SELECTIVE GOLD IN CONTACT AREA, MATTE TIN ON TAIL  
-H: 30µ" HEAVY GOLD IN CONTACT AREA, 3µ" GOLD ON TAIL (STYLE -04 ONLY)  
-L: 10µ" SELECTIVE GOLD IN CONTACT AREA, MATTE TIN ON TAIL

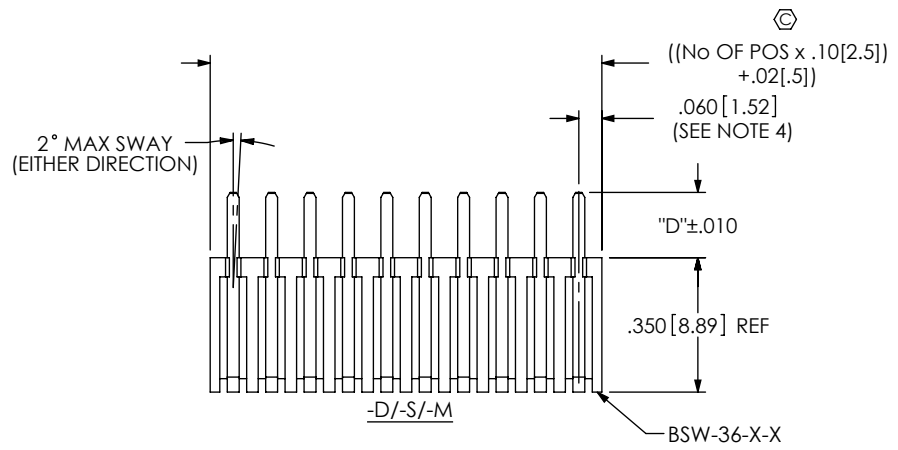

ROW / OPTION	"B"	"C"	"D"	USE BODY
- D	.100 [2.54]	—	.165 [4.19]	BSW-36-D
- S	.100 [2.54]	—	.170 [4.32]	BSW-36-S
- M	.150 [3.81]	—	.125 [3.18]	BSW-36-M
- D - S	.100 [2.54]	.15 [3.8]	—	BSW-36-D-S
- S - S	.100 [2.54]	.15 [3.8]	—	BSW-36-S-S

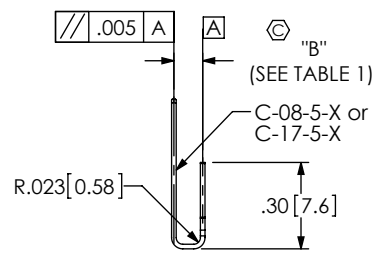
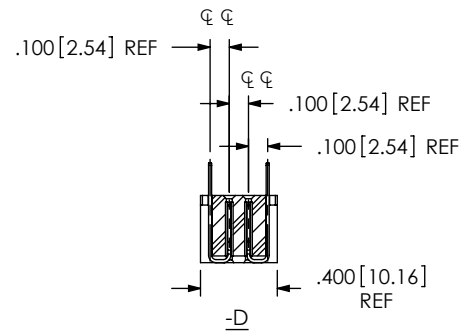
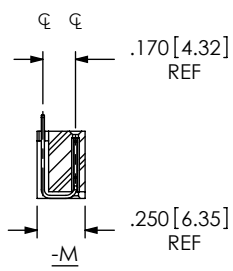
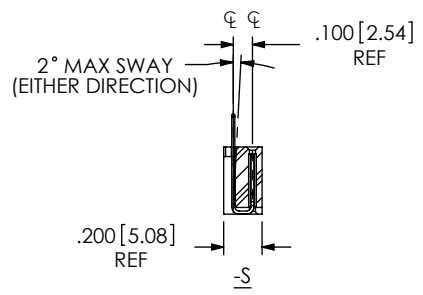

CONTACT SCALE 1.5:1  
CRITICAL 1 DIMENSION MUST BE VERIFIED AT BEGINNING, MIDDLE, AND END OF EACH LOT

FINAL ASSEMBLY

- NOTES:
- ⊕ REPRESENTS A CRITICAL DIMENSION.
  - MINIMUM PUSHOUT FORCE: 3lbs.
  - MAXIMUM ALLOWABLE BOW: T/B .003[.08] INCH/INCH, S/S .008[0.20] INCH/INCH AFTER ASSEMBLY.
  - "END WALLS" AFTER CUTTING SHOULD BE .023[.58]
  - MAXIMUM CUT FLASH: .010[.25].
  - THE IDENTIFICATION SIDE IS TO BE DOWN OR AGAINST THE FORM TOOLING.

POSITION NUMBER LAYOUT

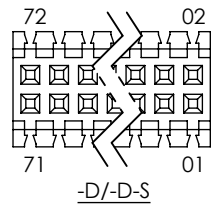
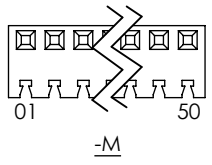
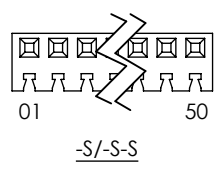

UNLESS OTHERWISE SPECIFIED, DIMENSIONS ARE IN INCHES.  
TOLERANCES ARE:  
DECIMALS ANGLES  
.XX: ±.01 [.3] 2°  
.XXX: ±.005 [.13]  
.XXXX: ±.0020 [.051]

PROPRIETARY NOTE  
THIS DOCUMENT CONTAINS INFORMATION CONFIDENTIAL AND PROPRIETARY TO SAMTEC, INC. AND SHALL NOT BE REPRODUCED OR TRANSFERRED TO OTHER DOCUMENTS OR DISCLOSED TO OTHERS OR USED FOR ANY PURPOSE OTHER THAN THAT WHICH IT WAS OBTAINED WITHOUT THE EXPRESSED WRITTEN CONSENT OF SAMTEC, INC.



520 PARK EAST BLVD, NEW ALBANY, IN 47150  
PHONE: 812-944-6733 FAX: 812-948-5047  
e-Mail: info@SAMTEC.com code 55322

DO NOT SCALE DRAWING SHEET SCALE: 2:1  
MATERIAL:  
INSULATOR: PET, UL 94 VO, COLOR: BLACK  
CONTACT: PHOS BRONZE

DESCRIPTION:  
.100 BOTTOM MOUNT SOCKET ASSEMBLY

DWG. NO. BSW-1XX-X4-X-X-X

BY: PURVIS 03/31/1998 SHEET 1 OF 2

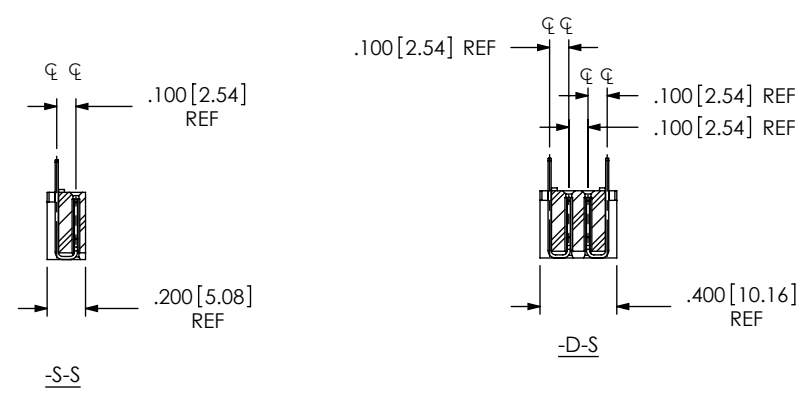
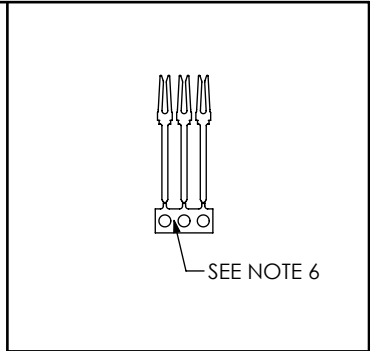
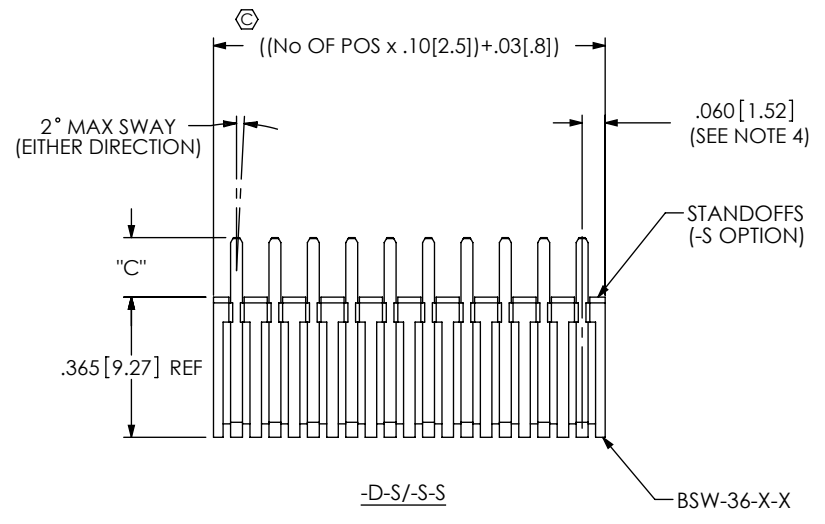

FINAL ASSEMBLY

**PROPRIETARY NOTE**  
 THIS DOCUMENT CONTAINS INFORMATION CONFIDENTIAL AND PROPRIETARY TO SAMTEC, INC. AND SHALL NOT BE REPRODUCED OR TRANSFERRED TO OTHER DOCUMENTS OR DISCLOSED TO OTHERS OR USED FOR ANY PURPOSE OTHER THAN THAT WHICH IT WAS OBTAINED WITHOUT THE EXPRESSED WRITTEN CONSENT OF SAMTEC, INC.

DO NOT SCALE DRAWING

SHEET SCALE: 2:1

	
520 PARK EAST BLVD, NEW ALBANY, IN 47150 PHONE: 812-944-6733 FAX: 812-948-5047 e-Mail info@SAMTEC.com code 55322	
DESCRIPTION:	
.100 BOTTOM MOUNT SOCKET ASSEMBLY	
DWG. NO.	BSW-1XX-X4-X-X-X
BY: PURVIS	03/31/1998
SHEET 2 OF 2	