

SANKEN

SANKEN
LIGHT EMITTING DIODES

T-1 Standard Type (Diffused)

SEL 2110 R SEL 2510 G
SEL 2110 W SEL 2710 Y
SEL 2310 G

FEATURES

- Mounting Requires Only a Small space
- Long-life/High Reliability
- Wide Viewing Angle/Diffused Type
- Selection of 4 Colors/Intensities
- Pulse-Drivable
- COMS/MOS, TTL Compatible

APPLICATIONS

- Low Power Circuit
- Portable Device
- For PCB Checking
- Display of Battery and Communication Devices

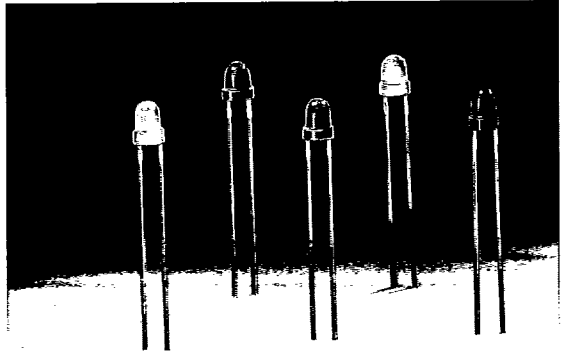

Package Dimensions

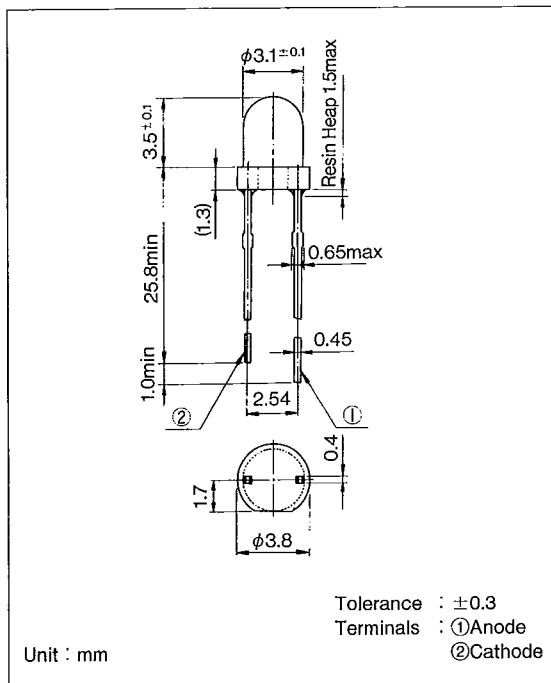

Intensity Ranks

Type No.	Intensity Min. (mcd)	Condition I _F (mA)	Color	
			Lens	Chip
SEL 2110 R A B C D	0.7	10	R	R
	0.8			
	1.1			
	1.5			
SEL 2110 W A B C D	0.7	10	W	R
	0.8			
	1.1			
	1.5			
SEL 2310 G A B C D	1.2	10	G	G
	2.2			
	3.0			
	4.0			
SEL 2510 G A B C D	1.7	20	G	PG
	2.6			
	3.7			
	5.4			
SEL 2710 Y A B C D	3.2	10	Y	Y
	5.5			
	7.0			
	9.0			

R=Red G=Green PG=Pure Green W=Opaline Y=Yellow

Individual Specifications

Electro-Optical Characteristics (Ta = 25°C)							
Symbol	Description	Type No.	Min.	Typ.	Max.	Unit	Test Condition
I_v	Intensity	SEL 2110 R, 2110 W SEL 2310 G SEL 2510 G SEL 2710 Y	0.7 1.2 1.7 3.2	1.5 4.0 5.4 9.0		mcd	$I_F=10$ (mA) * SEL 2510 G Only $I_F=20$ (mA)
$2\theta_{1/2}$	Including Angle Between Half Intensity Points	SEL 2110 R, 2110 W SEL 2310 G SEL 2510 G SEL 2710 Y		60°		Deg	$I_F=10$ (mA) See Note 1
λ_p	Peak Wavelength	SEL 2110 R, 2110 W SEL 2310 G SEL 2510 G SEL 2710 Y		700 560 555 570		nm	$I_F=10$ (mA)
$\Delta\lambda$	Spectral Line Halfwidth	SEL 2110 R, 2110 W SEL 2310 G SEL 2510 G SEL 2710 Y		100 28 20 40		nm	
λ_d	Dominant Wavelength	SEL 2110 R, 2110 W SEL 2310 G SEL 2510 G SEL 2710 Y		650 562 555 566		nm	See Note 2
C	Capacitance	SEL 2110 R, 2110 W SEL 2310 G SEL 2510 G SEL 2710 Y		38 15 42 15		pF	$V_F=0$ $f=1$ (MHz)
V_F	DC Forward Voltage	SEL 2110 R, 2110 W SEL 2310 G SEL 2510 G SEL 2710 Y	1.5	2.0	3.0	V	$I_F=10$ (mA)
V_R	DC Reverse Voltage	SEL 2110 R, 2110 W SEL 2310 G SEL 2510 G SEL 2710 Y	5.0			V	$I_R=100$ (μ A)

- Notes : 1. $\theta_{1/2}$ is the off-axis angle at which the intensity is half the axial intensity.
 2. The dominant wavelength, λ_d , is derived from the CIE chromaticity diagram and it represents the single wavelength which defines the color of the device.

Absolute Maximum Ratings (Ta = 25°C)

Symbol	Description	Ratings	Unit
I _p	Peak Forward Current*1	100	mA
I _F	Max. DC Forward Current*2	30	mA
V _R	DC Reverse Voltage (I _R = 100μA)	5	V
I _{FP}	Transient Max. Peak Forward Current*3 (10μsec Pulse)	500	mA
T _{op}	Operating Temp. Range	-55 to +100	°C
T _{stg}	Storage Temp. Range	-55 to +100	
T _{slid}	Lead Soldering Temp. (more than 4.0 mm from body)	260°C for 5 seconds	

- Notes : 1. See Figure 4
 2. This current derates linearly from 25°C at 0.33 mA/°C
 3. Only for one pulse

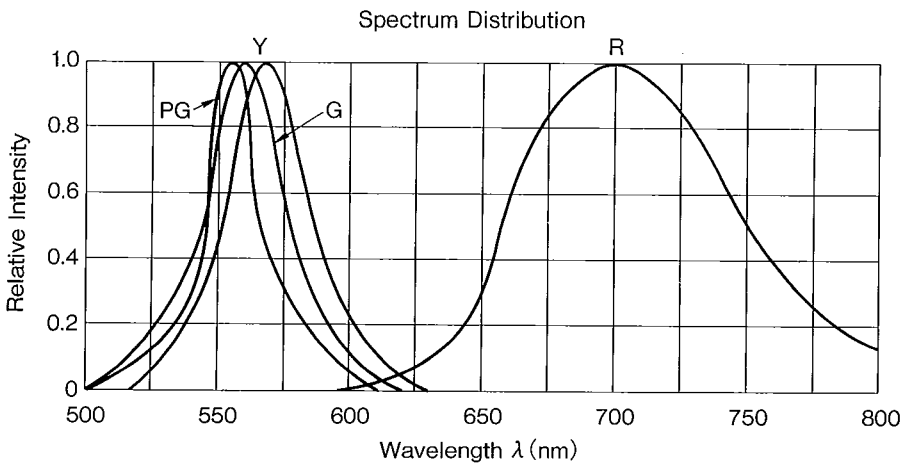

Fig. 1 : Relative Intensity vs. Wavelength

Individual Specifications

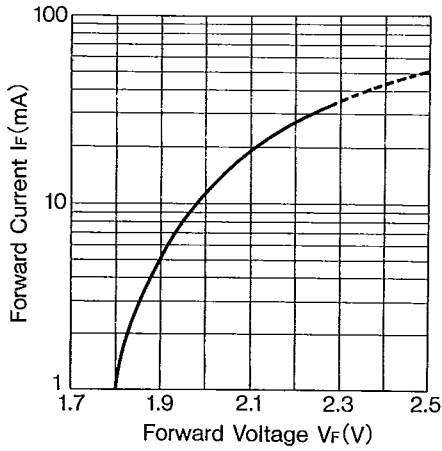

Fig.2 : Forward Current vs. Forward Voltage

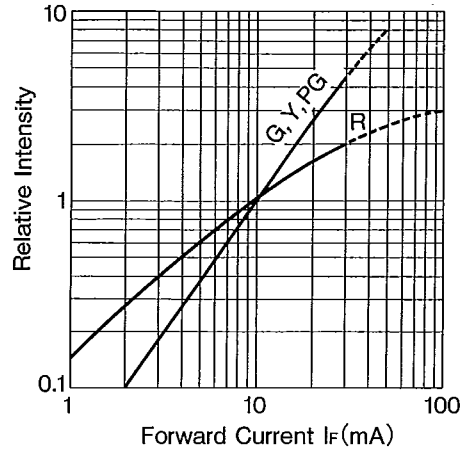

Fig.3 : Relative Intensity vs. Forward Current

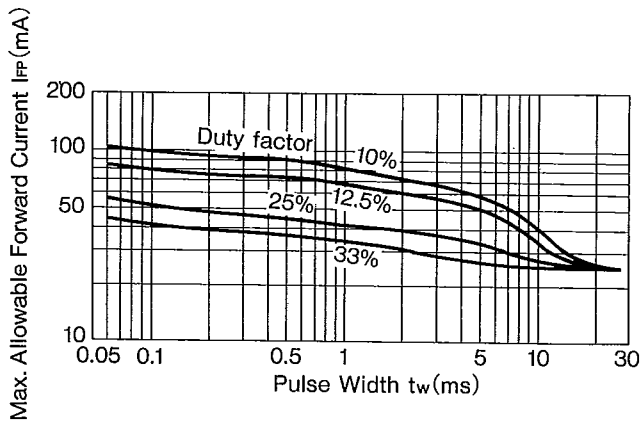

Fig.4 : Max. Allowable Forward Current vs. Pulse Width

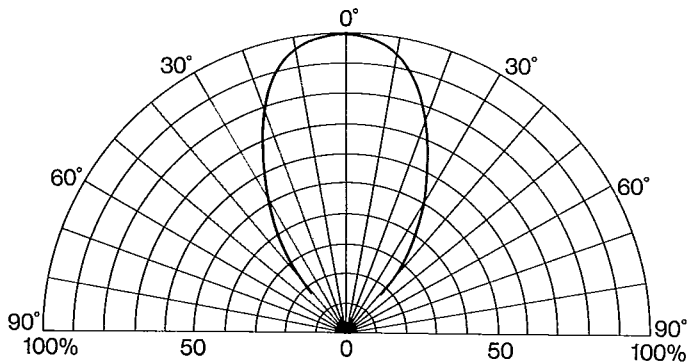

Fig.5 : Viewing Angle