

# MBR1040FCT THRU MBR10200FCT

## List

List..... 1

Package outline..... 2

Features..... 2

Mechanical data..... 2

Maximum ratings .....2

Electrical characteristics..... 2

Rating and characteristic curves..... 3

Pinning information.....4

Marking..... 4

Tube packing.....4

Suggested thermal profiles for soldering processes..... 5

High reliability test capabilities.....6

# MBR1040FCT THRU MBR10200FCT

## 10A High Barrier Power Schottky Rectifiers - 40V-200V

### Features

- Low power loss, high efficiency.
- High current capability
- High surge capability.
- Guardring for overvoltage protection.
- Low stored charge majority carrier conduction
- Silicon epitaxial planar chip, metal silicon junction.
- Lead-free parts meet environmental standards of MIL-STD-19500 /228
- Suffix "-H" indicates Halogen-free parts, ex. MBR1040FCT-H.

### Mechanical data

- Epoxy : UL94-V0 rated flame retardant
- Case : JEDEC ITO-220AB molded plastic body over passivated chip
- Lead : Axial leads, solderable per MIL-STD-202, Method 208 guaranteed
- Polarity: As marked
- Mounting Position : Any
- Weight : Approximated 1.70 gram

### Package outline

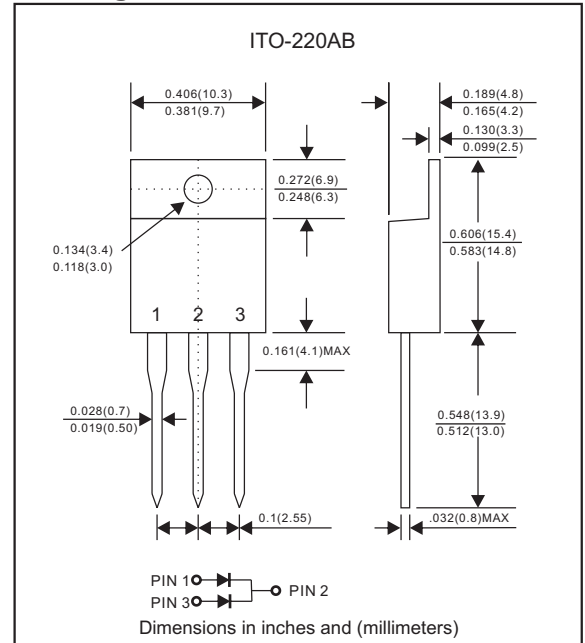

### Maximum ratings (AT $T_A=25^\circ\text{C}$ unless otherwise noted)

PARAMETER	SYMBOLS	MBR 1040FCT	MBR 1045FCT	MBR 1050FCT	MBR 1060FCT	MBR 1080FCT	MBR 10100FCT	MBR 10150FCT	MBR 10200FCT	UNIT	
Maximum repetitive peak reverse voltage	$V_{RRM}$	40	45	50	60	80	100	150	200	V	
Maximum RMS voltage	$V_{RMS}$	28	31.5	35	42	56	70	105	140	V	
Maximum DC blocking voltage	$V_{DC}$	40	45	50	60	80	100	150	200	V	
Maximum average forward rectified current Per device	$I_o$	10								A	
Peak forward surge current 8.3ms single half sine-wave(JEDEC method)	$I_{FSM}$	125								A	
Operating junction temperature range	$T_J$					-55 to +150			-55 to +175		$^\circ\text{C}$
Storage temperature range	$T_{STG}$	-65 to +175								$^\circ\text{C}$	

### Electrical characteristics (AT $T_A=25^\circ\text{C}$ unless otherwise noted)

PARAMETER	SYMBOLS	MBR 1040FCT	MBR 1045FCT	MBR 1050FCT	MBR 1060FCT	MBR 1080FCT	MBR 10100FCT	MBR 10150FCT	MBR 10200FCT	UNIT
Maximum forward voltage at $I_F=5A$ at $I_F=10A$	$V_F$	0.65 0.84		0.75 0.85		0.85 0.95		0.92 1.00		V
Maximum DC reverse current at $T_J=25^\circ\text{C}$ at rated DC blocking voltage at $T_J=125^\circ\text{C}$	$I_R$		0.05 10				0.01 10			mA mA

### Thermal characteristics

PARAMETER	SYMBOLS	MBR 1040FCT	MBR 1045FCT	MBR 1050FCT	MBR 1060FCT	MBR 1080FCT	MBR 10100FCT	MBR 10150FCT	MBR 10200FCT	UNIT
Typical thermal resistance junction to case per leg	$R_{\theta JC}$	3.0								$^\circ\text{C}/\text{W}$

## Rating and characteristic curves (MBR1040FCT THRU MBR10200FCT)

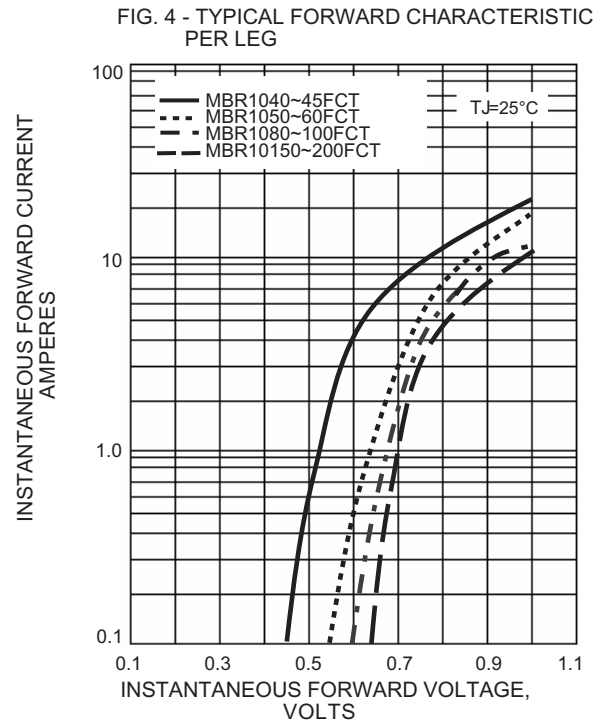
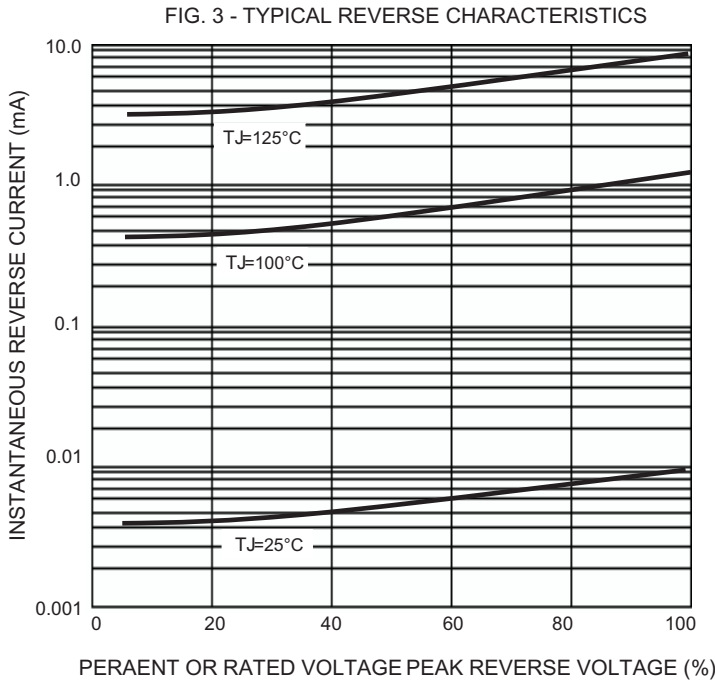
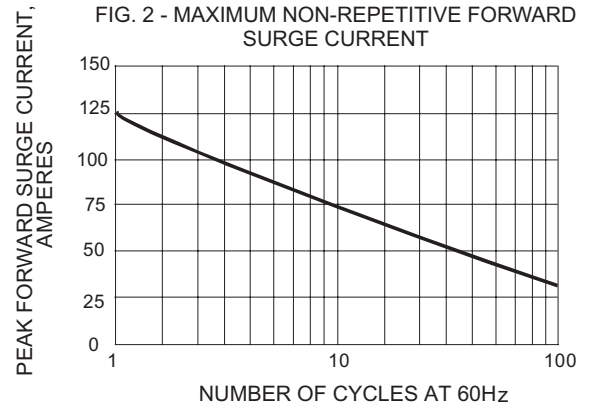
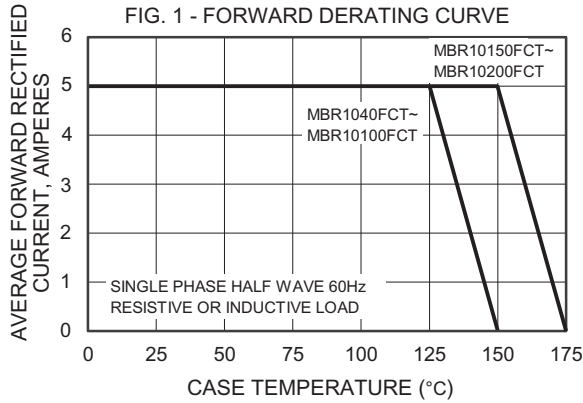

# MBR1040FCT THRU MBR10200FCT

## Pinning information

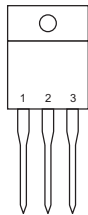
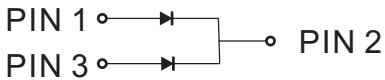
Pin	Simplified outline	Symbol
Pin1 anode Pin2 cathode Pin3 anode		

## Marking

Type number	Marking code
MBR1040FCT	MBR1040FCT
MBR1045FCT	MBR1045FCT
MBR1050FCT	MBR1050FCT
MBR1060FCT	MBR1060FCT
MBR1080FCT	MBR1080FCT
MBR10100FCT	MBR10100FCT
MBR10150FCT	MBR10150FCT
MBR10200FCT	MBR10200FCT

## Tube packing

PACKAGE	TUBE (pcs)	TUBE SIZE (m/m)	BOX (pcs)	INNER BOX (m/m)	CARTON SIZE (m/m)	CARTON (pcs)	APPROX. GROSS WEIGHT (kg)
ITO-220AB	50	525*32*7.0	1,000	555*150*40	580*230*175	5,000	15.0

# MBR1040FCT THRU MBR10200FCT

## Suggested thermal profiles for soldering processes

### 1. Lead free temperature profile wave-soldering

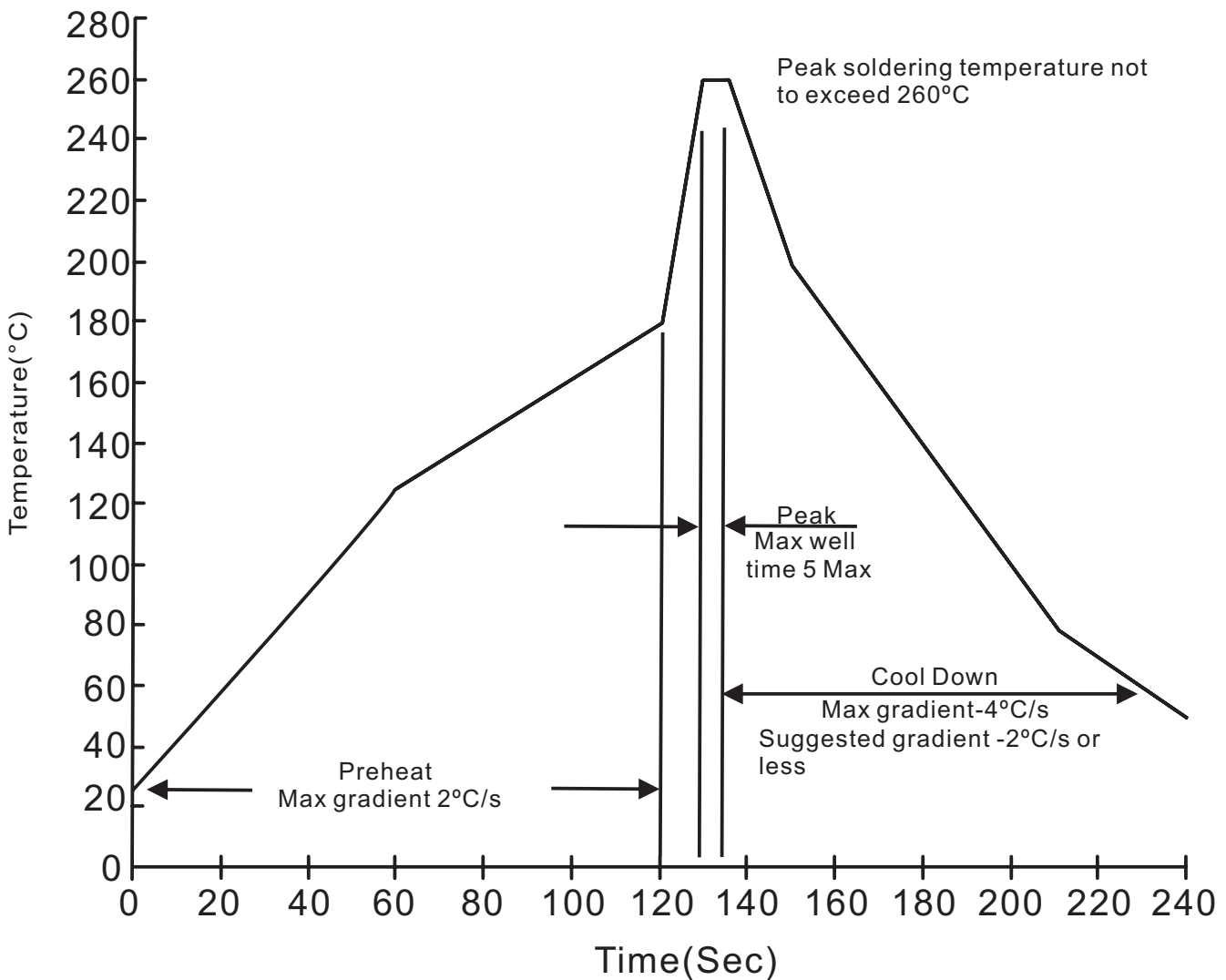

# MBR1040FCT THRU MBR10200FCT

## High reliability test capabilities

Item Test	Conditions	Reference
1. Solder Resistance	at $260\pm 5^{\circ}\text{C}$ for $10\pm 2\text{sec}$ . immerse body into solder $1/16''\pm 1/32''$	MIL-STD-750D METHOD-2031
2. Solderability	at $245\pm 5^{\circ}\text{C}$ for 5 sec.	MIL-STD-202F METHOD-208
3. High Temperature Reverse Bias	$V_R=80\%$ rate at $T_J=150^{\circ}\text{C}$ for 168 hrs.	MIL-STD-750D METHOD-1038
4. Forward Operation Life	Rated average rectifier current at $T_A=25^{\circ}\text{C}$ for 500hrs.	MIL-STD-750D METHOD-1027
5. Intermittent Operation Life	$T_A = 25^{\circ}\text{C}$ , $I_F = I_O$ On state: power on for 5 min. off state: power off for 5 min. on and off for 500 cycles.	MIL-STD-750D METHOD-1036
6. Pressure Cooker	$15P_{SIG}$ at $T_A=121^{\circ}\text{C}$ for 4 hrs.	JESD22-A102
7. Temperature Cycling	$-55^{\circ}\text{C}$ to $+125^{\circ}\text{C}$ dwelled for 30 min. and transferred for 5min. total 10 cycles.	MIL-STD-750D METHOD-1051
8. Forward Surge	8.3ms single half sine-wave , one surge.	MIL-STD-750D METHOD-4066-2
9. Humidity	at $T_A=85^{\circ}\text{C}$ , RH=85% for 1000hrs.	MIL-STD-750D METHOD-1021
10. High Temperature Storage Life	at $175^{\circ}\text{C}$ for 1000 hrs.	MIL-STD-750D METHOD-1031