

### DESCRIPTIONS

It is adaptable to a discontinuous mode of operation that the IP3002 is PFC (Power Factor Correction) controller for the high density switching mode power supply and electronic ballast systems. The bulky external components are eliminated in the internal start-up circuits, though it is taken in independent boost converter operation. What is more, instead of the external components, the low pass filter is mounted in internal current sense block. Internal clamping of the error amplifier and multiplier output improve turn on overshoot characteristics and current limiting. The one of features is able to prevent abnormal condition, open lamp & over voltage.

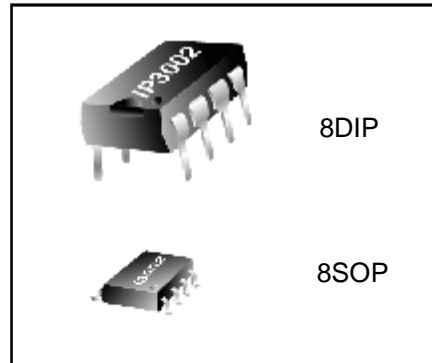

### APPLICATIONS

- Switching Mode Power Supply (SMPS)
- Electronics Ballast

### FEATURES

- Very Precise Adjustable Output OVP (Dynamic & Static OVP Function)
- Extremely Low Start-Up Current
- Very Low Operating Supply Current
- Internal Start-Up Timer
- Current Sense Filter On Chip
- Disable Function
- Extremely Minimized External Part Counts
- 8DIP / 8SOP package

### ORDER INFORMATION

Order Part	PKG	Marking	Plating	Packing
IP3002	8DIP	IP3002	-	Tube
IP3002L		IP3002L	L-Free	Tube
I3002	8SOP	I3002	-	Tube
I3002-TF			-	T & R
I3002L		I3002L	L-Free	Tube
I3002L-TF				T & R

### BLOCK DIAGRAM

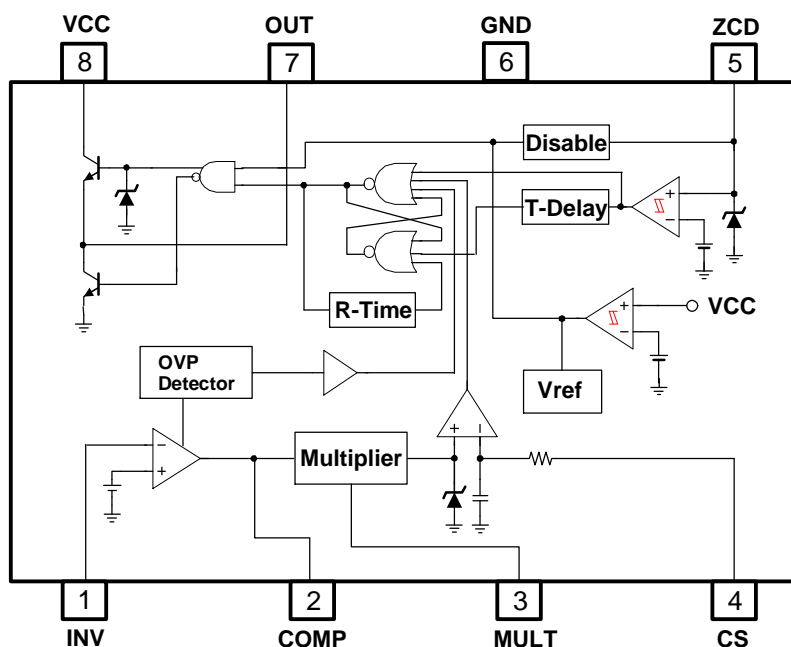

### PIN CONNECTIONS

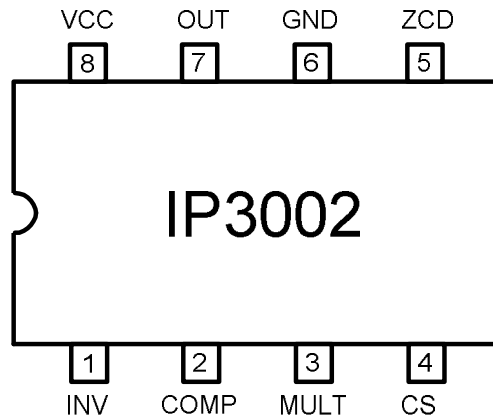

### PIN DESCRIPTIONS

NO	SYMBOL	I/O	DESCRIPTION
1	INV	I	Inverting Input of Error Amplifier
2	COMP	O	Output of Error Amplifier
3	MULT	I	Input of The Multiplier Stage
4	CS	I	Current Sense Input
5	ZCD	I	Current Driven Logic Input
6	GND	-	Ground
7	OUT	O	Output
8	VCC	-	Supply Voltage

### ABSOLUTE MAXIMUM RATINGS

CHARACTERISTICS	SYMBOL	VALUE	UNIT
Maximum Supply Voltage	VCCmax	27	V
Output Peak Current	Ipeak	500	mA
Analog Inputs & Outputs (Pin 1,2,3,4,5)	Vinmax	-0.3 ~ 7	V
ZCD Input Maximum Current	Izcd	±10	mA
Power Dissipation (8DIP)	Pdmax	800	mW
Power Dissipation (8SOP)	Pdmax	600	mW
Operating Junction Temperature	Tj	-35 ~ 150	°C
Storage Temperature	Tstg	-65 ~ 150	°C

**ELECTRICAL CHARACTERISTICS**

(Ta = -25°C to 125°C, VCC=14V unless otherwise specified.)

CHARACTERISTICS	SYMBOL	CONDITIONS	MIN	TYP	MAX	UNIT
<b>Supply Voltage &amp; Current Section</b>						
Start-up Threshold Voltage	Vth(st)	VCC Increasing	11	12	13	V
Hysteresis Voltage	HYS		2	2.5	3	V
Start-Up Current	Ist	Before Turn-On(VCC=11V)	20	50	90	uA
Quiescent Current	Iq	No Switching	1	4	7	mA
Operating Supply Current	Icc	CL=1nF,fsw=50KHz	2	5	8	mA
Operating Current at OVP	Icc_ovp	Vinv=2.7V	0.5	2	4	mA
Operating Current at Disable	Icc_dis	Vzcd<150mV	0.5	2	4	mA
<b>Error Amplifier Section</b>						
Input Voltage	Vinv	Ta=25°C	2.465	2.5	2.535	V
Line Regulation	dVinv	VCC=12 ~ 27V	-	0.1	5	mV
Input Bias Current	Iinv		-0.5	-0.1	0.5	uA
Open Loop Gain	Av		60	80	-	dB
Gain Bandwidth	GB		-	1	-	MHz
Output Source Current	Isource	Vcomp=4V,Vinv=2.4V	-2	-4	-	mA
Output Sink Current	Isink	Vcomp=4V,Vinv=2.6V	3	5	-	mA
Upper Clamp Voltage	Vupper	Io=-100uA,Vinv=2.4V	-	5.6	-	V
Lower Clamp Voltage	Vlower	Io=100uA,Vinv=2.6V	-	2.25	-	V

**ELECTRICAL CHARACTERISTICS (Continued)**

(Ta = -25°C to 125°C, VCC=14V unless otherwise specified.)

CHARACTERISTICS	SYMBOL	CONDITIONS	MIN	TYP	MAX	UNIT
<b>Multiplier Section</b>						
Linear Operating Voltage	Vmult		3	3.5	-	V
Output Maximum Slope	dVcs/dVmult	Vmult=0.5~0.9V, Vcomp=Upper Clamp	1.3	1.5	1.7	
Multiplier Gain	K	Ta=25°C Vmult=1V, Vcomp=3.5V	0.45	0.6	0.75	1/V
<b>Current Sense (CS) Section</b>						
Reference Clamp Voltage	Vcs	Vmult=2.5V, Vcomp=Upper Clamp	1.6	1.75	1.9	V
Input Bias Current	Ics	Vcs=0~1.6V	-1	0	1	uA
<b>Zero Current Detector (ZCD) Section</b>						
Input Threshold Voltage	Vzcd	Vzcd Increasing	1.8	2.1	2.4	V
Hysteresis Voltage	HY(zcd)		-	0.5	-	V
Upper Clamp Voltage	Vclamp(h)	Izcd=3mA	5	5.6	6.4	V
Lower Clamp Voltage	Vclamp(l)	Izcd=-3mA	0.3	0.65	-	V
Input Bias Current	Izcd	Vzcd=1~3V	-	1	-	uA
Source Current	Isource(zcd)		-3	-	-	mA
Sink Current	Isink(zcd)		3	-	-	mA
Disable Input Voltage	Vdis	Vzcd Decreasing	150	200	250	mV
Reset Current after Disable	Idis	Pin5=0V	-100	-200	-300	uA
<b>Restart Timer Section</b>						
Restart Time delay	trst		70	150	400	us

**ELECTRICAL CHARACTERISTICS (Continued)**

(Ta = -25°C to 125°C, VCC=14V unless otherwise specified.)

CHARACTERISTICS	SYMBOL	CONDITIONS	MIN	TYP	MAX	UNIT
<b>Output Section</b>						
High Voltage	Voh	Io = -10mA	11	12	13	V
Maximum Voltage	Vomax	VCC=20V, Io=-100uA	12	14	16	V
Low Voltage	Vol	Io=10mA	-	-	1	V
Voltage with UVLO Activated	Vo(uv)	Io=5mA	-	-	1	V
Rising Time	tr	CL=1nF	-	100	-	ns
Falling Time	tf	CL=1nF	-	50	-	ns
<b>Over Voltage Protector (OVP) Section</b>						
Dynamic OVP Bias Current	Iovp		35	40	45	uA
Static OVP Threshold Voltage	Vovp	Vinv=2.7V	2.1	2.25	2.4	V

## APPLICATION INFORMATIONS

### 1. Main Inductor

$$L = \eta * (V_O - V_P) * V_P^2 / (4 * V_O * P_O * f)$$

Where,

$\eta$ : Efficiency ( 0.95)  
 $V_O$ : DC Link Voltage  
 $V_P$ : Input Peak Voltage  
 $P_O$ : Output Power  
 $f$ : Switching Frequency

### 2. Resistor for Current Sense

$$R_S = 1.6 / I_{LP}$$

Where,

$I_{LP}$ : Inductor Peak Current

### 3. Resistors for Multiplier

$$R_{ML} < 0.69 * R_{MU} / (V_P - 0.69)$$

Where,

$R_{MU}$ : Upper Resistor for Multiplier Input  
 $R_{ML}$ : Lower Resistor for Multiplier Input

### 4. Resistors for Error Amplifier

$$R_{EL} = 2.5 * R_{EU} / (V_O - 2.5)$$

Where,

$R_{EU}$ : Upper Resistor for Error Amplifier Inverting Input  
 $R_{EL}$ : Lower Resistor for Error Amplifier Inverting Input

**APPLICATION INFORMATIONS (Continued)**

**5. Over Voltage Protector (OVP)**

$$\Delta V_O[V] = R_{EU}[\Omega] * 40[\mu A]$$

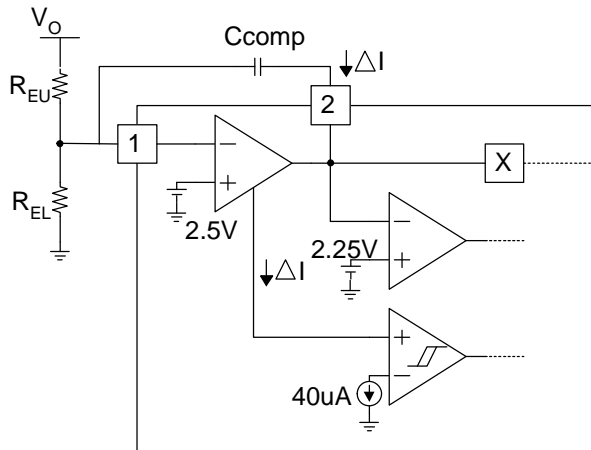

Fig.1 : Over Voltage Protection Circuit

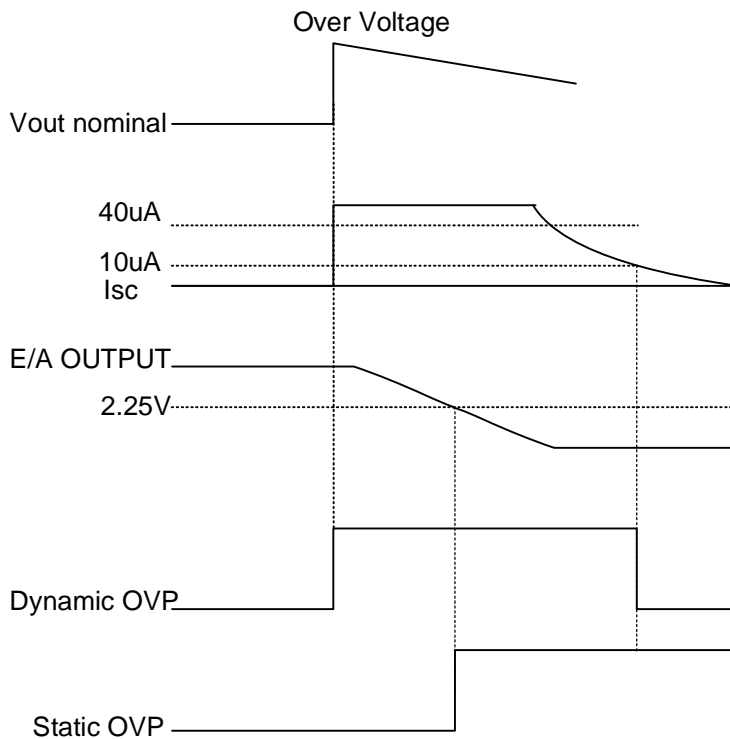
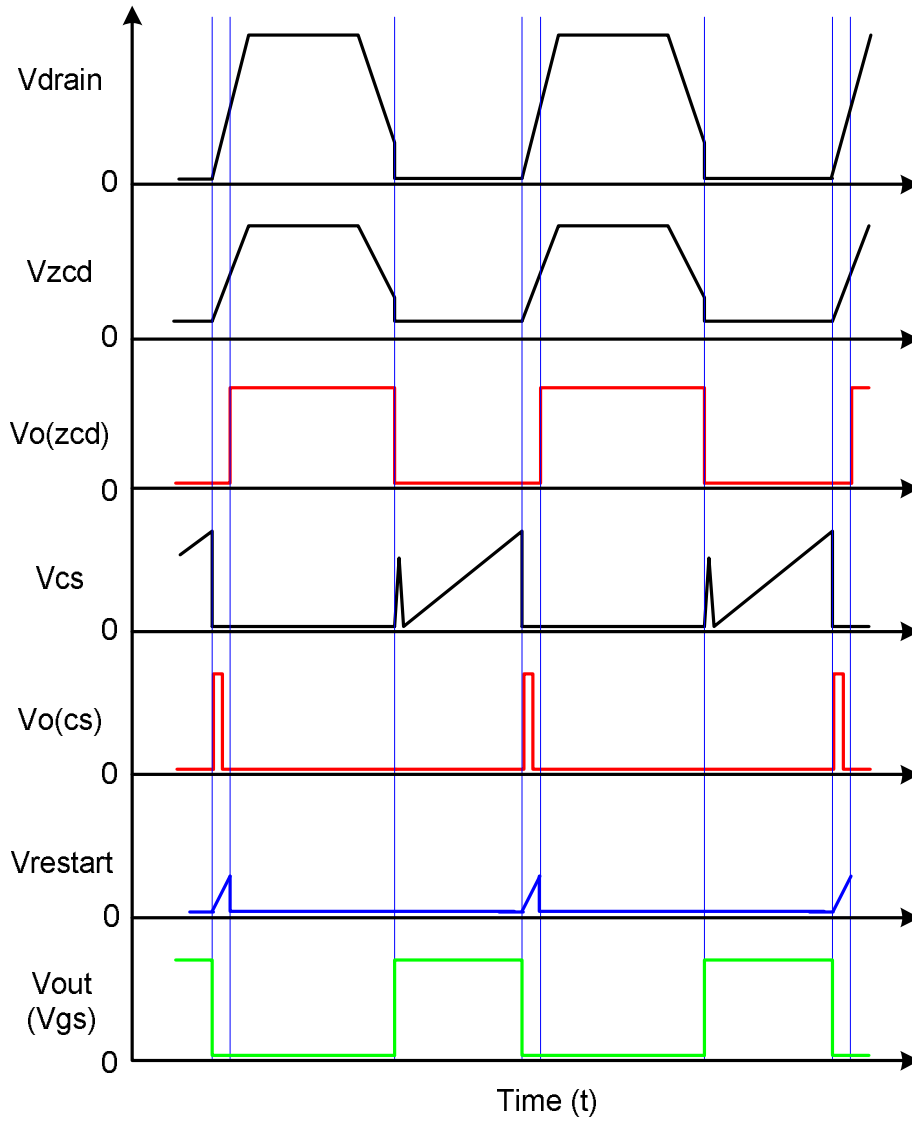

Fig.2: OVP Operation Timing Chart

OPERATING TIMING CHART





### TEST CIRCUITS

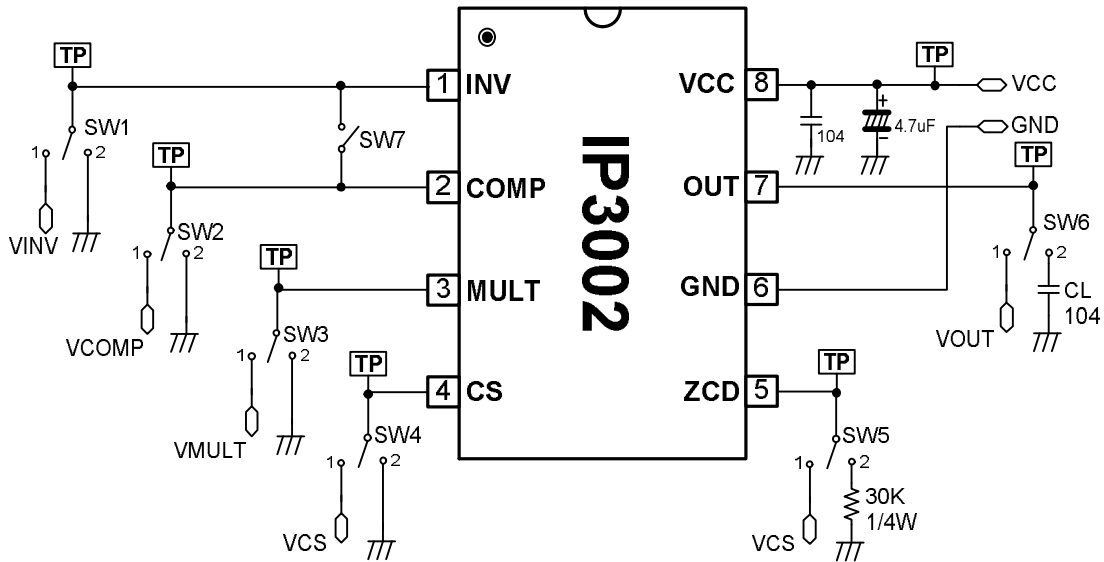

### TYPICAL APPLICATION CIRCUITS (80V<sub>AC</sub> ~ 300V<sub>AC</sub>, 80W)

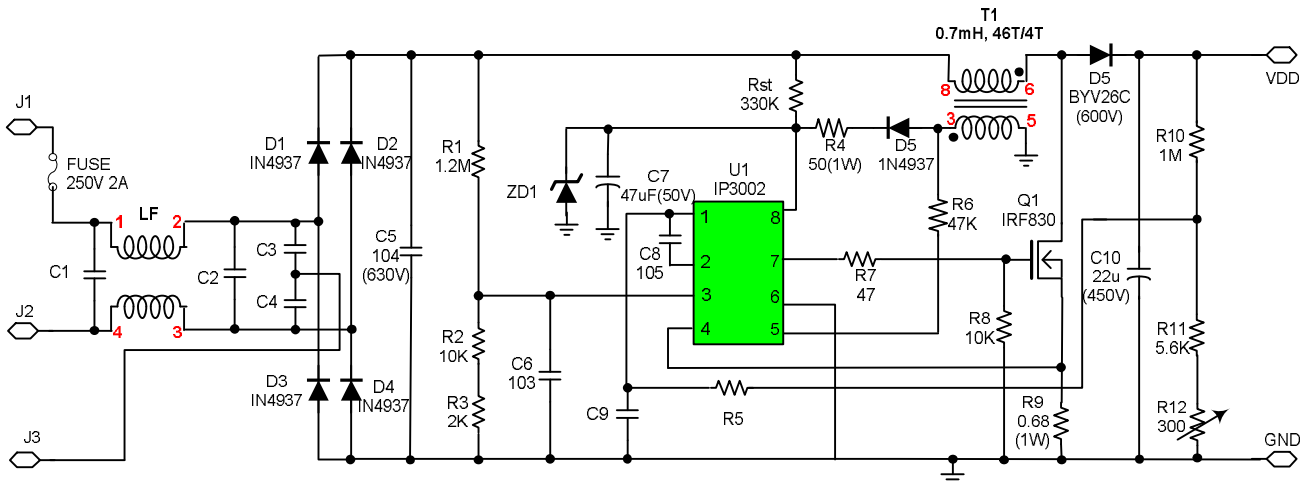

**ELECTRICAL CHARACTERISTICS CURVES**

Operating Supply Current

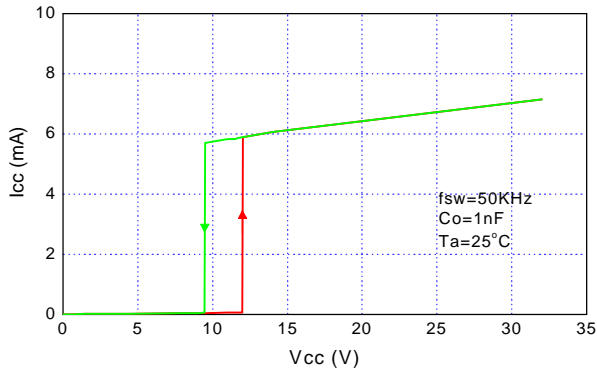

Vcc Start-up Current

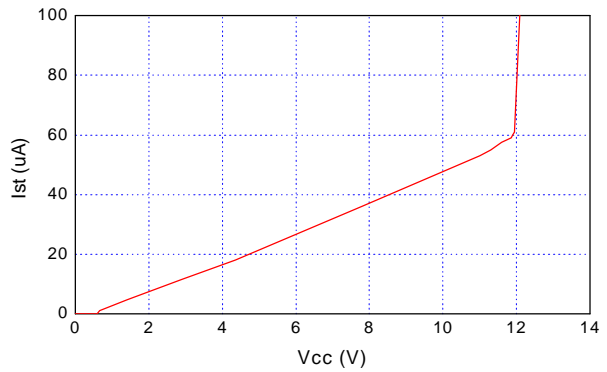

Quiescent Current vs. Temperature

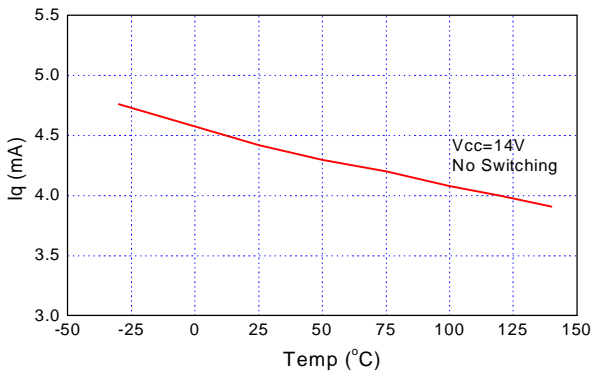

UVLO On/Off Voltage vs. Temp

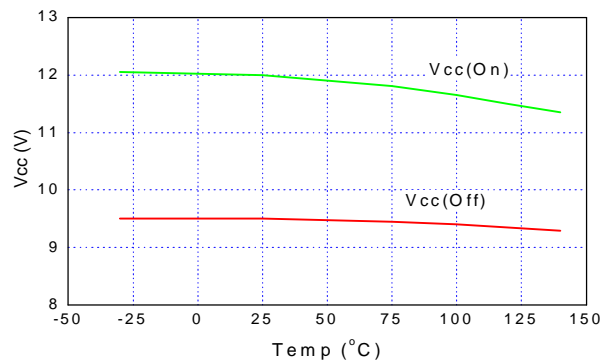

Voltage Feedback Input vs. Temperature

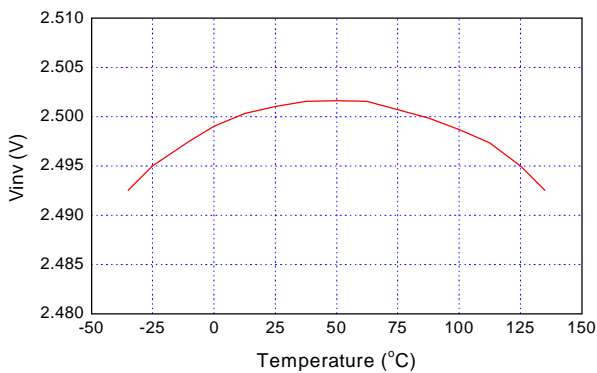

Multiplier Input vs. CS Threshold Voltage

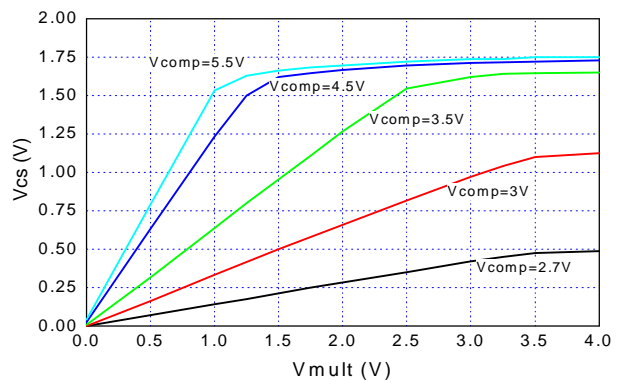

### ELECTRICAL CHARACTERISTICS CURVES (Continued)

Multiplier Gain vs. Temperature

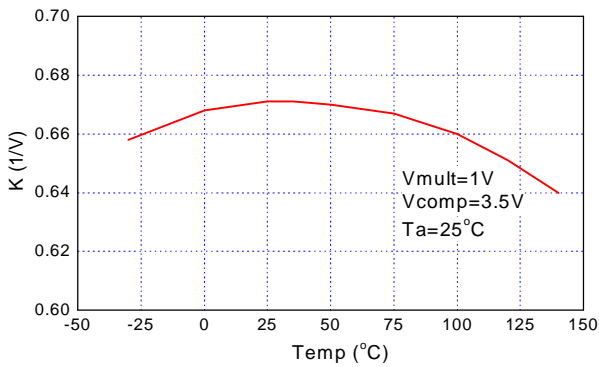

Dynamic OVP Current vs. Temperature

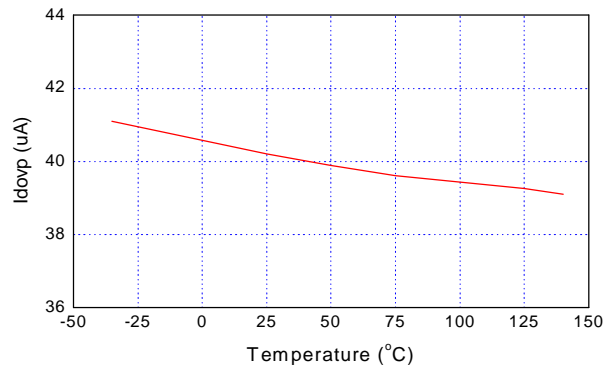

ZCD Input Threshold Voltage

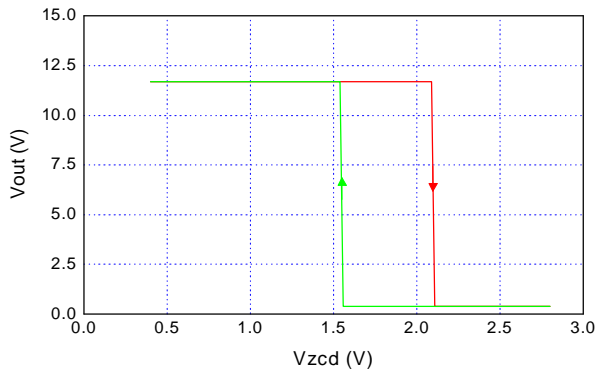

Disable Input Threshold Voltage

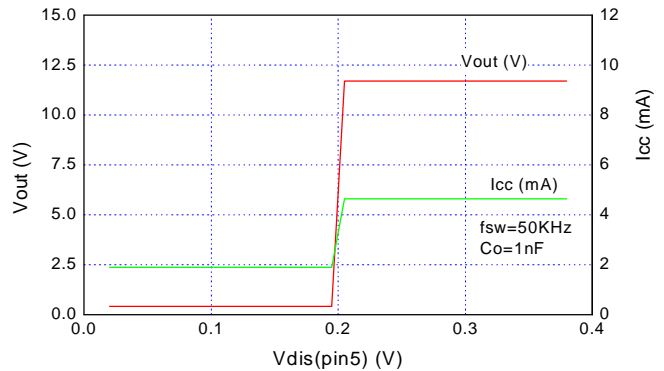

Output High Voltage

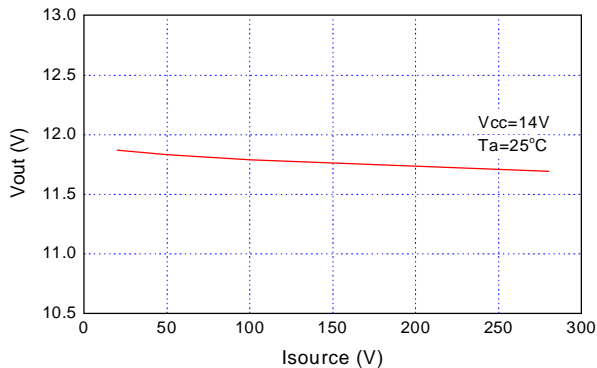

Output Low Voltage

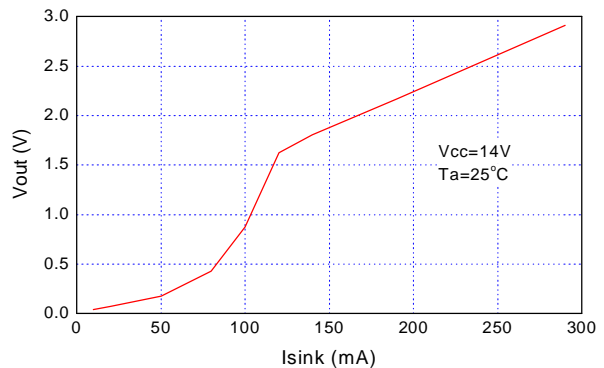

**PACKAGE DIMENSION**

**8-DIP**

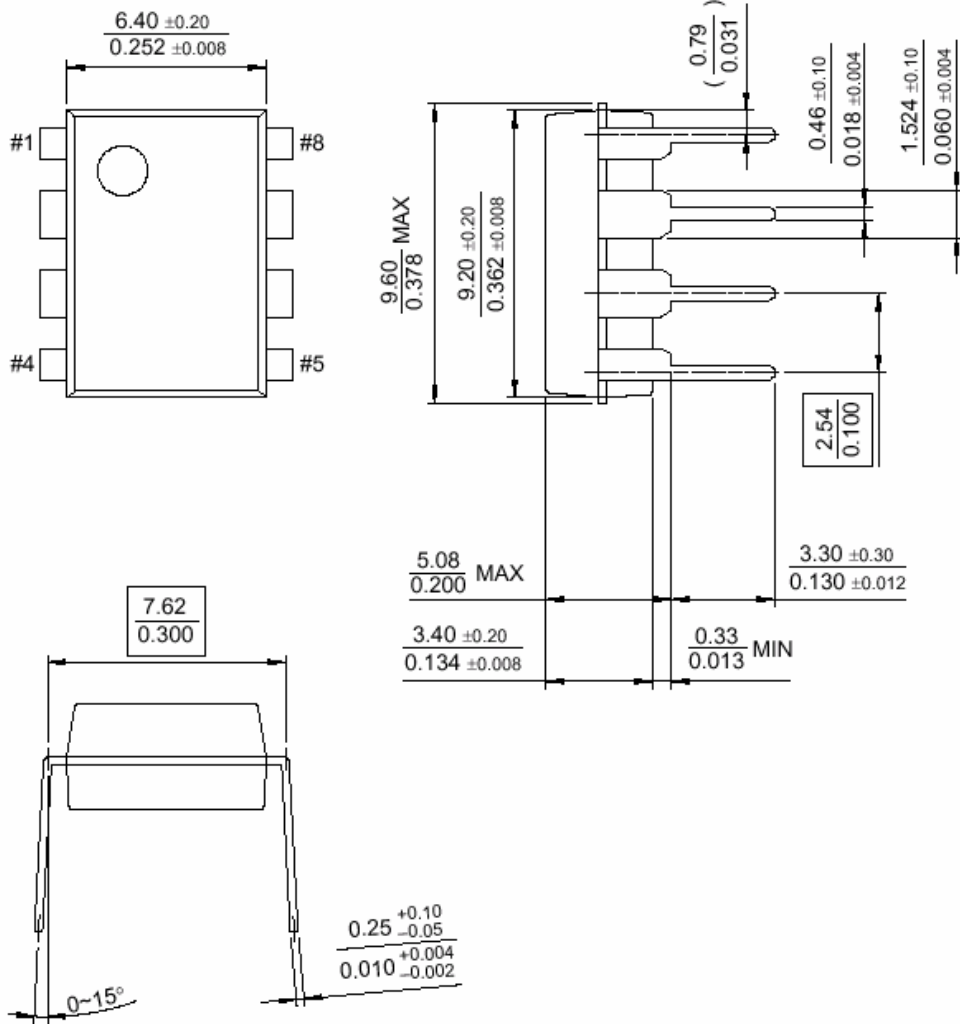

**PACKAGE DIMENSION**

**8-SOP**

