

### Features

- High accuracy  $5\text{ V} \pm 2\%$
- Very low-drop voltage
- Very low quiescent current
- Low starting-current consumption
- Proof against reverse polarity
- Input voltage up to 42 V
- Overvoltage protection up to 65 V ( $\leq 400\text{ ms}$ )
- Short-circuit-proof
- External setting of reset delay
- Integrated watchdog circuit
- Wide temperature range
- Overtemperature protection
- Suitable for automotive use
- EMC proofed (100 V/m)

Type	Ordering Code	Package
▼ TLE 4261-2	Q67000-A9110	P-TO220-7-1
▼ TLE 4261-2 G	Q67000-A9140	P-DSO-20-6 (SMD)
▼ TLE 4261-2 GL	Q67006-A9193	P-TO220-7-8 (SMD)

▼ Please also refer to the new pin compatible device  
TLE 4271

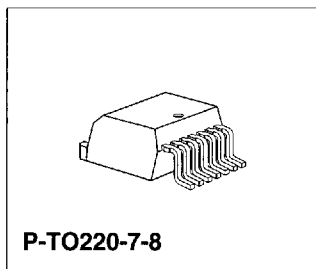
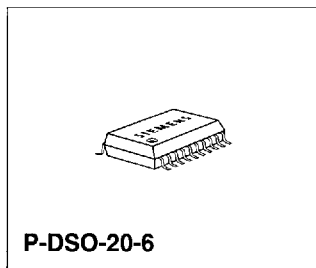
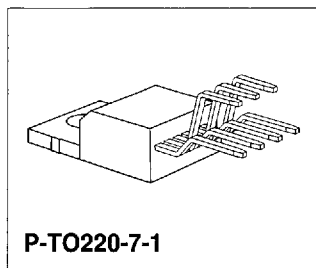

### Functional Description

TLE 4261-2 is a high accuracy 5-V low-drop voltage regulator in a P-TO220-7 or in a P-DSO package. The maximum input voltage is 42 V (65 V/ $\leq 400\text{ ms}$ ). The device can produce an output current of more than 500 mA. It is short-circuit-proof and incorporates temperature protection that disables the circuit at impermissibly high temperatures.

■ 8235605 0118603 733 ■

### Application Description

The IC regulates an input voltage  $V_I$  in the range  $6\text{ V} < V_I < 40\text{ V}$  to  $V_{\text{Orated}} = 5.0\text{ V}$ . A reset signal is generated for an output voltage  $V_O$  of  $< 4.75\text{ V}$ . The reset delay can be set with an external capacitor. A connected microprocessor is monitored by the integrated watchdog circuit; if pulses are missing, the reset output is set low. The pulse repetition rate can be set within wide limits with the capacitor for reset delay. If this input is connected to a voltage of  $> 6\text{ V}$ , the watchdog function is deactivated. The device also features an inhibit input, which is activated by a voltage of  $> 6\text{ V}$  and then works on this input through internal hysteresis up to approx.  $3\text{ V}$ . A voltage of  $< 2\text{ V}$  on the inhibit input turns off the regulator, current drain then dropping to max.  $50\text{ }\mu\text{A}$ .

### Design Notes for External Components

The input capacitor  $C_I$  causes a low-resistance powerline and limits the rise times of the input voltage. The IC is protected against rise times up to  $100\text{ V}/\mu\text{s}$ . It is possible to damp the tuned circuit consisting of supply inductance and input capacitance with a resistor of approx.  $1\text{ }\Omega$  in series to  $C_I$ .

The output capacitor maintains the stability of the regulating loop. Stability is guaranteed with a rating of  $22\text{ }\mu\text{F}$  min. at an ESR of  $3\text{ }\Omega$  max. in the operating temperature range.

### Circuit Description

The control amplifier compares a reference voltage, which is kept highly accurate by resistance adjustment, to a voltage that is proportional to the output voltage and controls the base of the series PNP transistor via a buffer. Saturation control as a function of the load current prevents any over-saturation of the power element. If the output voltage drops below 95.5% of its typical value for more than  $2\text{ }\mu\text{s}$ , a reset signal is triggered on pin 3 and an external capacitor discharged on pin 5. The reset signal is not cancelled until the voltage on the capacitor has exceeded the upper switching threshold  $V_{\text{DT}}$ . A positive-edge-triggered watchdog circuit monitors the connected microprocessor and will likewise trigger a reset if pulses are missing. The IC can be disabled by a low level on the inhibit input and the current consumption drops to  $< 50\text{ }\mu\text{A}$ .

The IC also incorporates a number of circuits for protection against:

- Overload
- Overvoltage
- Overtemperature
- Reverse polarity

■ 8235605 0118604 67T ■

## Pin Configuration (top view)

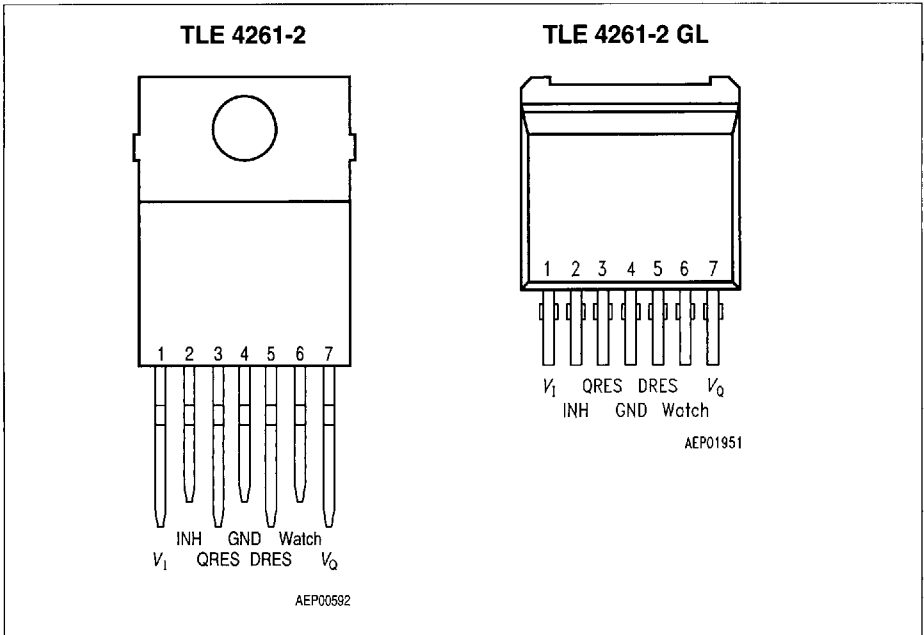

## Pin Definitions and Functions

Pin No.	Symbol	Function
1	$V_1$	<b>Input voltage;</b> block a capacitor directly to ground on the IC. The capacitor rating will depend on the vehicle electric system. Oscillation of the output voltage can be damped by a resistor of approx. $1 \Omega$ in series with the input capacitor.
2	INH	<b>Inhibit;</b> switches off the IC when low.
3	QRES	<b>Reset output;</b> open collector output controlled by the reset delay.
4	GND	<b>Ground</b>
5	DRES	<b>Reset delay;</b> wired to ground using a capacitor.
6	Watch	<b>Watchdog;</b> monitors the microprocessor when active.
7	$V_Q$	<b>5-V output;</b> block to ground using a capacitor of $\geq 22\text{-}\mu\text{F}$ . ESR is $\leq 3 \Omega$ in the operating temperature range.

8235605 0118605 506

TLE 4261-2 G

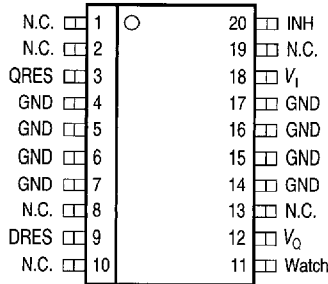

AEP01182

Pin No.	Symbol	Function
18	V <sub>1</sub>	<b>Input voltage</b> ; block a capacitor directly to ground on the IC. The capacitor rating will depend on the vehicle electric system. Oscillation of the output voltage can be damped by a resistor of approx. 1 Ω in series with the input capacitor.
20	INH	<b>Inhibit</b> ; switches off the IC when low.
3	QRES	<b>Reset output</b> ; open collector output controlled by the reset delay.
4 -7, 14 - 17	GND	<b>Ground</b>
9	DRES	<b>Reset delay</b> ; wired to ground using a capacitor.
11	Watch	<b>Watchdog</b> ; monitors the microprocessor when active.
12	V <sub>Q</sub>	<b>5-V output</b> ; block to ground using a capacitor of ≥ 22-μF. ESR is ≤ 3 Ω in the operating temperature range.
1, 2, 8, 10, 13, 19	N.C.	<b>Not connected</b>

8235605 0118606 442

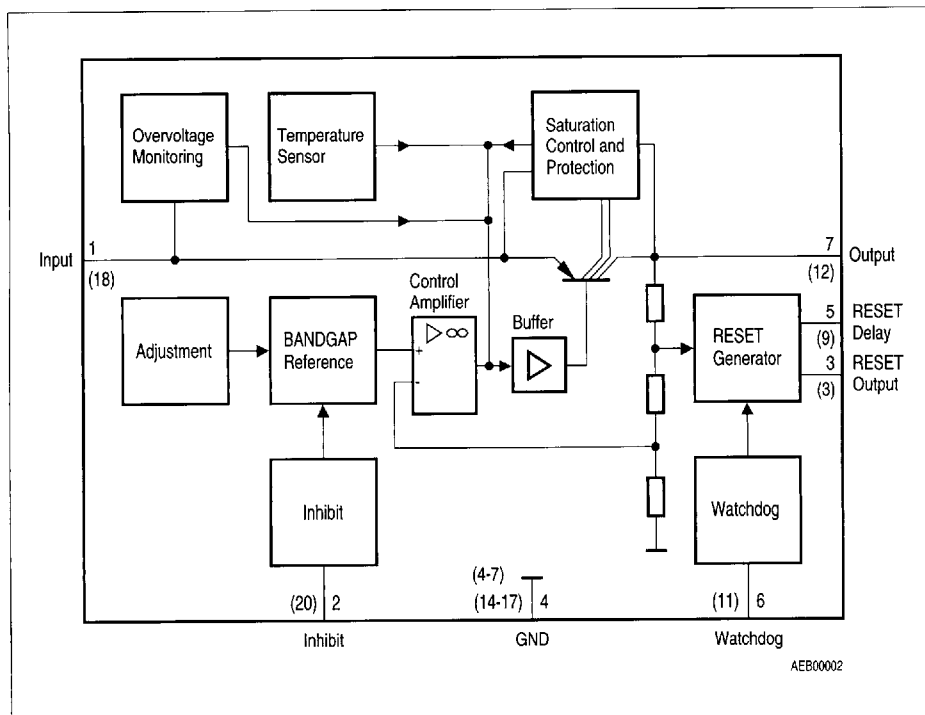

**Block Diagram**

■ 8235605 0118607 389 ■

**Absolute Maximum Ratings** $T_J = -40$  to  $150$  °C

Parameter	Symbol	Limit Values		Unit	Remarks
		min.	max.		

**Input**

Input voltage	$V_1$	- 42	42	V	-
	$V_1$	-	65	V	$t \leq 400$ ms
Input current	$I_1$	-	1.6	A	-

**Inhibit**

Voltage	$V_2$	- 0.3	42	V	-
Current	$I_2$	-	5	mA	-

**Reset Output**

Voltage	$V_R$	- 0.3	42	V	-
Current	$I_R$	-	-	-	internally limited

**Ground**

Current	$I_{GND}$	-	0.5	A	-
---------	-----------	---	-----	---	---

**Reset Delay**

Voltage	$V_D$	- 0.3	42	V	-
Current	$I_D$	-	-	-	internally limited

**Output**

Differential voltage	$V_1 - V_Q$	- 5.25	$V_1$	V	-
Current	$I_Q$	-	1.4	A	-

### Absolute Maximum Ratings (cont'd)

$T_J = -40$  to  $150$  °C

Parameter	Symbol	Limit Values		Unit	Remarks
		min.	max.		

### Temperature

Junction temperature	$T_J$	–	150	°C	–
Storage temperature	$T_{stg}$	– 50	150	°C	–

### Operating Range

Input voltage	$V_I$ <sup>1)</sup>	–	32	V	–
Junction temperature	$T_J$	– 40	150	°C	–

### Thermal Resistance

System-air	$R_{thSA}$	–	65 (70) <sup>2)</sup>	K/W	–
System-case	$R_{thSC}$	–	3 (15) <sup>2)</sup>	K/W	–

<sup>1)</sup> see diagram

<sup>2)</sup> Figures in parenthesis refer to TLE 4261-2 G.

■ 8235605 0118609 151 ■

## Characteristics

$V_1 = 13.5 \text{ V}$ ;  $T_j = 25 \text{ }^\circ\text{C}$ ;  $V_s \geq 6 \text{ V}$  (unless otherwise specified)

Parameter	Symbol	Limit Values			Unit	Test Condition
		min.	typ.	max.		

## Normal Operation

Output voltage	$V_Q$	4.9	5.0	5.1	V	$I_Q = 100 \text{ mA}$ $-40 \text{ }^\circ\text{C} \leq T_j \leq 125 \text{ }^\circ\text{C}$
Output current	$I_Q$	-	-	50	$\mu\text{A}$	$0 \text{ V} \leq V_1 \leq 2 \text{ V}$ ; $V_2 = V_1$ ; $-40 \text{ }^\circ\text{C} \leq T_j \leq 125 \text{ }^\circ\text{C}$
Output current	$I_Q$	500	1000	-	mA	$V_1 = 17 \text{ V}$ to $28 \text{ V}$
Current consumption $I_q = I_1 - I_Q$	$I_q$	-	-	3.5	mA	$I_Q = 0 \text{ mA}$ , $V_W > 6 \text{ V}$
Current consumption $I_q = I_1 - I_Q$	$I_q$	-	-	10	mA	$6 \text{ V} \leq V_1 \leq 28 \text{ V}$ $I_Q = 150 \text{ mA}$
Current consumption $I_q = I_1 - I_Q$	$I_q$	-	5.0	65	mA	$6 \text{ V} \leq V_1 \leq 28 \text{ V}$ $I_Q = 500 \text{ mA}$
Current consumption $I_q = I_1 - I_Q$	$I_q$	-	40	80	mA	$V_1 \leq 6 \text{ V}$ $I_Q = 500 \text{ mA}$
Drop voltage	$V_{DR}$	-	0.35	0.5	V	$V_1 = 4.5 \text{ V}$ ; $I_Q = 0.5 \text{ A}$
Drop voltage	$V_{DR}$	-	0.2	0.3	V	$V_1 = 4.5 \text{ V}$ ; $I_Q = 0.15 \text{ A}$
Load regulation	$\Delta V_Q$	-	15	35	mV	$25 \text{ mA} \leq I_Q \leq 500 \text{ mA}$
Supply-voltage regulation	$\Delta V_Q$	-	15	50	mV	$V_1 \leq 6 \text{ V}$ to $28 \text{ V}$ ; $I_Q = 100 \text{ mA}$
Supply-voltage regulation	$\Delta V_Q$	-	5	25	mV	$V_1 \leq 6 \text{ V}$ to $16 \text{ V}$ ; $I_Q = 100 \text{ mA}$
Ripple rejection	$SVR$	-	54	-	dB	$f = 100 \text{ Hz}$ ; $V_r = 0.5 V_{SS}$
Temperature drift of output voltage	$\alpha_{VQ}$	-	$2 \times 10^{-4}$	-	$1/^\circ\text{C}$	-

■ 8235605 0118610 973 ■



**Characteristics (cont'd)**

$V_1 = 13.5 \text{ V}$ ;  $T_j = 25 \text{ }^\circ\text{C}$ ;  $V_s \geq 6 \text{ V}$  (unless otherwise specified)

Parameter	Symbol	Limit Values			Unit	Test Condition
		min.	typ.	max.		

**Inhibit Operation**

Current consumption	$I_1$	–	–	50	$\mu\text{A}$	$V_2 = 2 \text{ V}$ ; $I_Q = 0$
Current consumption	$I_2$	–	–	100	$\mu\text{A}$	$V_2 = 6 \text{ V}$
Switching threshold for inhibit	$V_2$	5.0	5.5	6.0	V	IC turned ON
Switching threshold for inhibit	$V_2$	2.0	2.7	3.7	V	IC turned OFF

**Reset Generator**

Switching threshold	$V_{RT}$	94	95.5	97	%	in % of $V_Q$ ; $I_Q > 500 \text{ mA}$ ; $V_1 = 6 \text{ V}$
Saturation voltage, reset output	$V_R$	–	0.25	0.40	V	$I_R = 1 \text{ mA}$
Reverse current	$I_R$	–	–	1	$\mu\text{A}$	$V_R = 5 \text{ V}$
Charge current	$I_D$	18.75	25	31.25	$\mu\text{A}$	$V_C = 1.5 \text{ V}$
Switching threshold	$V_{ST}$	0.9	1	1.1	V	–
Delay switching threshold	$V_{DT}$	2.25	2.50	2.75	V	–
Saturation voltage, delay output	$V_C$	–	–	100	mV	$V_1 = 4.5 \text{ V}$ and $I_d$
Delay time	$t_D$	–	10	–	ms	$C_D = 100 \text{ nF}$
Delay time	$t_t$	–	2	–	$\mu\text{s}$	–

■ 8235605 0118611 80T ■

### Characteristics (cont'd)

$V_1 = 13.5 \text{ V}$ ;  $T_j = 25 \text{ }^\circ\text{C}$ ;  $V_s \geq 6 \text{ V}$  (unless otherwise specified)

Parameter	Symbol	Limit Values			Unit	Test Condition
		min.	typ.	max.		

### Watchdog

Turn-OFF voltage	$V_W$	5.2	5.6	6.0	V	–
Discharge current	$I_{CD}$	5.6	7.5	9.4	$\mu\text{A}$	$V_C = 1.5 \text{ V}$
Switching voltage	$V_{CD}$	2.95	3.05	3.15	V	–
Pulse intervall	$T_W$	–	35	–	ms	$C_D = 100 \text{ nF}$

### General Data

Turn-Off voltage	$V_{IOFF}$	41	43	45	V	$I_Q < 1 \text{ mA}$
Turn-Off hysteresis	$\Delta V_I$	–	6.5	–	V	–
Leakage current	$I_{QS}$	–	–	50	$\mu\text{A}$	$V_Q = 0 \text{ V}$ ; $V_1 = 45 \text{ V}$
Reverse output current	$I_{QR}$	–	–	1.5	mA	$V_Q = 5 \text{ V}$ ; $V_1$ and $V_2$ open

■ 8235605 0118612 746 ■

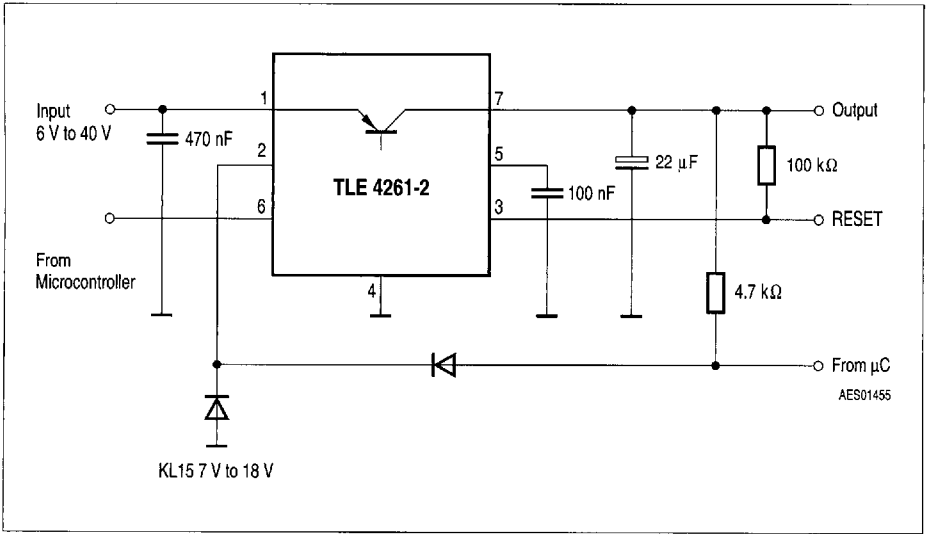

Application Circuit

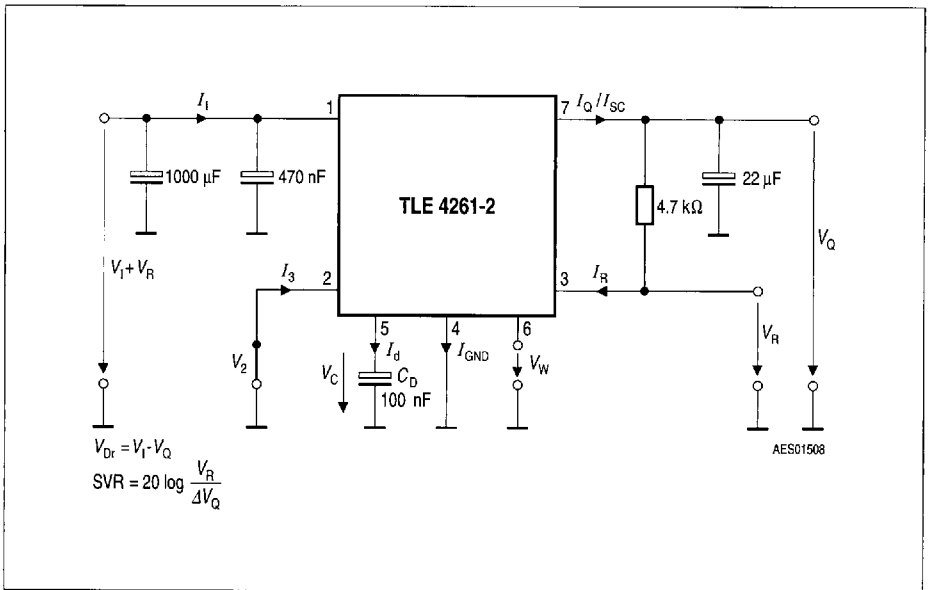

Test Circuit

8235605 0118613 682

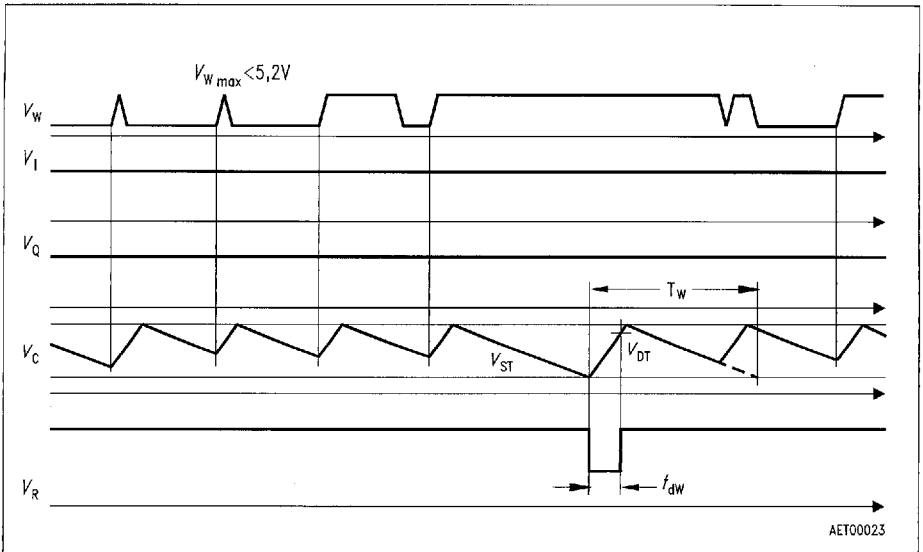

Time Response in Watchdog Condition

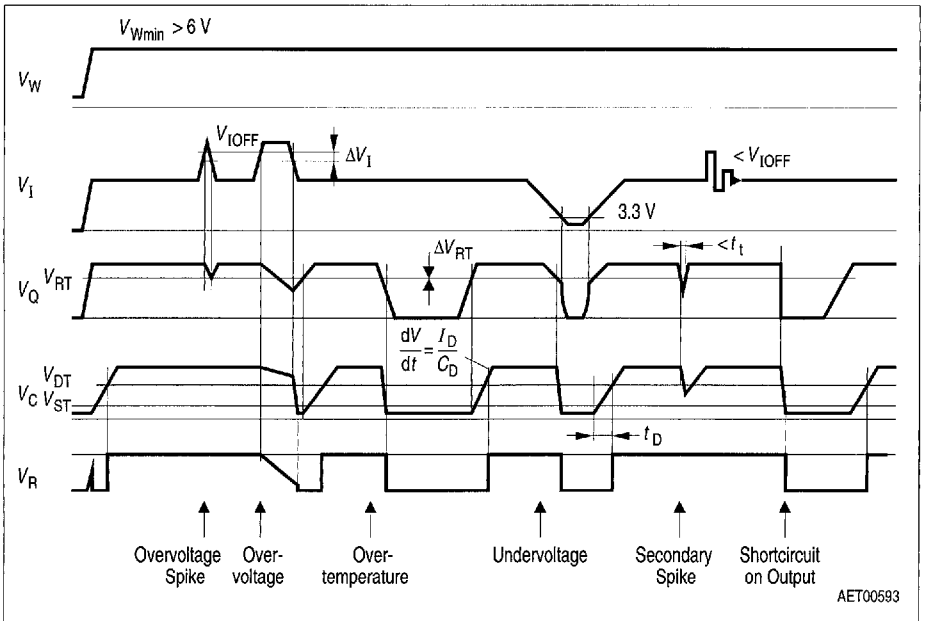

Timing with Watchdog OFF

■ 8235605 0118614 519 ■

Drop Voltage versus Output Current

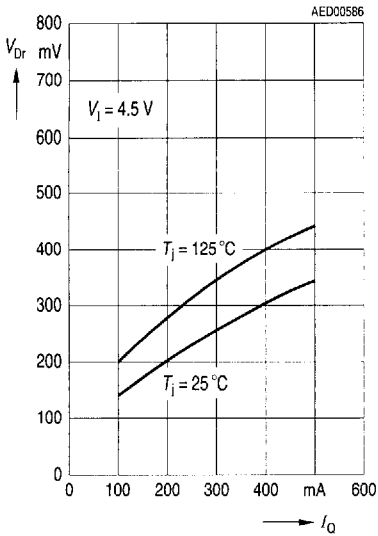

Output Voltage versus Input Voltage

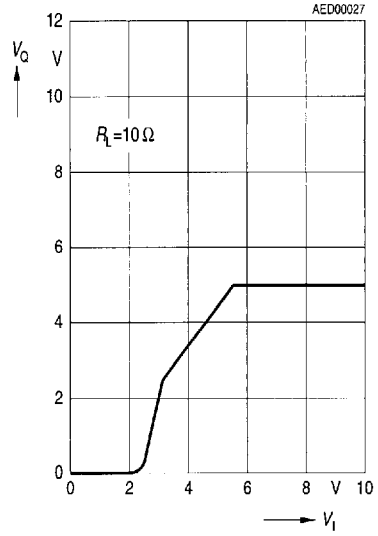

Current Consumption versus Input Voltage

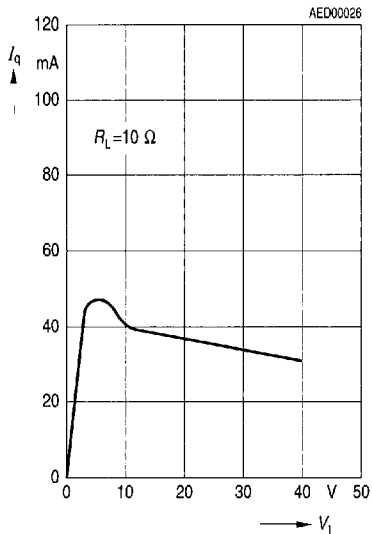

Current Consumption versus Output Current

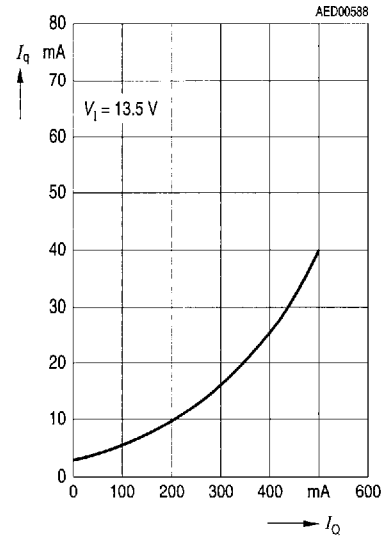

Charge Current  $I_D$  and Discharge Current  $I_{CD}$  versus Temperature

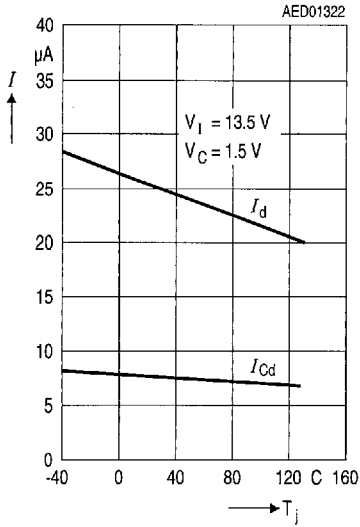

Switching Voltage  $V_{CD}$  and  $V_{ST}$  versus Temperature

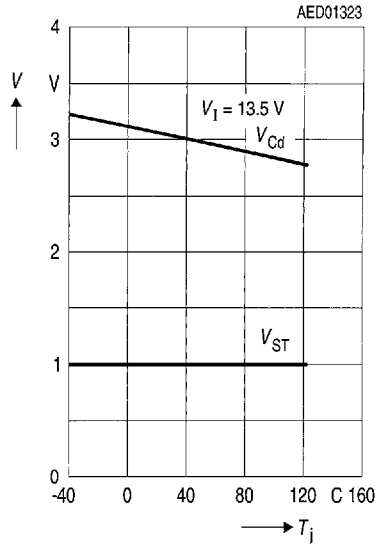

Pulse Interval  $T_W$  versus Temperature

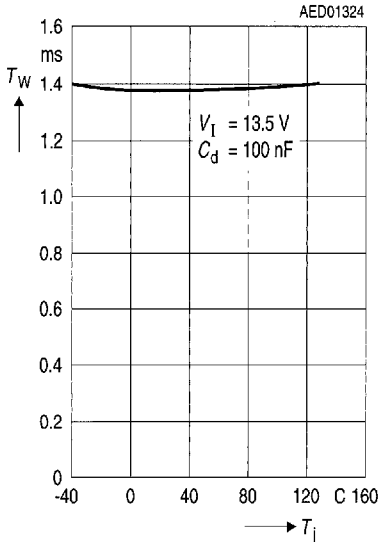

Output Voltage versus Temperature

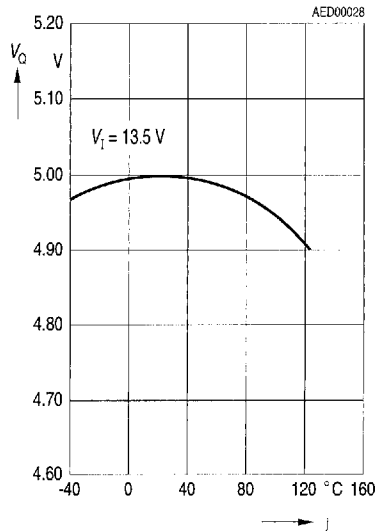

8235605 0118616 391

**Current Consumption of Inhibit at the Switching Point versus Temperature**

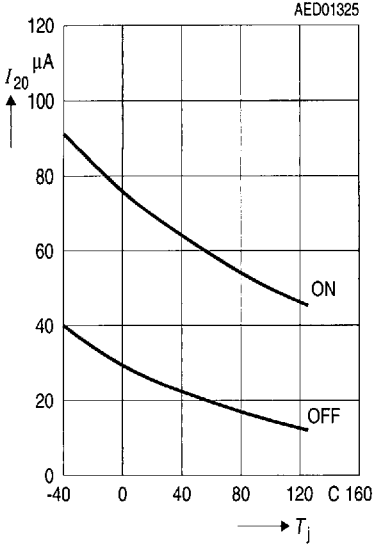

**Output Current versus Input Voltage**

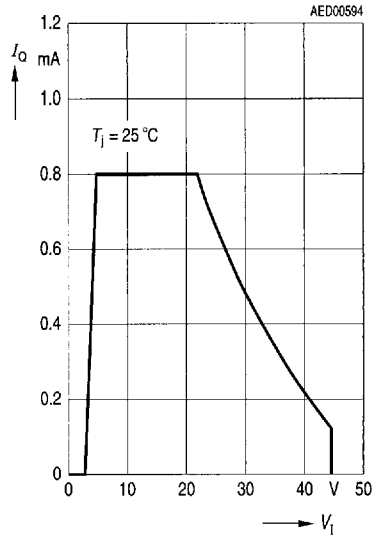

**Input Step Response**

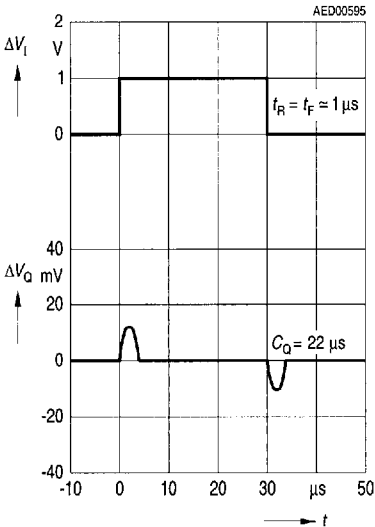

**Load Step Response**

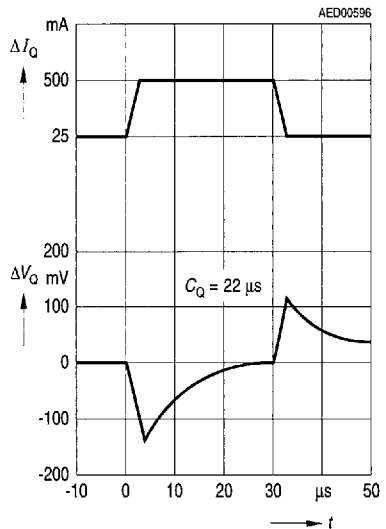

■ 8235605 0118617 228 ■

## Package Outlines

### P-TO220-7-1

(Plastic Transistor Single Outline)

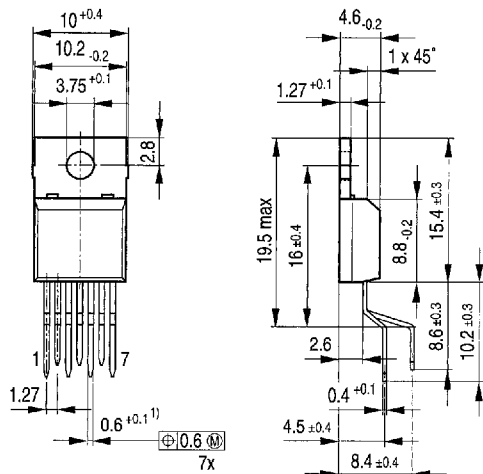

1) 0.75<sup>-0.15</sup> at dam bar (max 1.8 from body)

1) 0.75<sup>-0.15</sup> im Dichtstegbereich (max 1.8 vom Körper)

GPT05108

### Sorts of Packing

Package outlines for tubes, trays etc. are contained in our Data Book "Package Information".

8235605 0118618 164

Dimensions in mm



**P-TO220-7-8**  
**(Plastic Transistor Single Outline)**

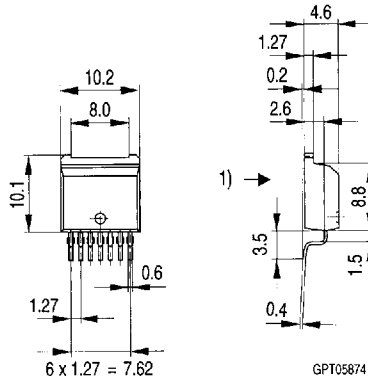

1) shear and punch direction burr free surface

**Sorts of Packing**

Package outlines for tubes, trays etc. are contained in our Data Book "Package Information".

**SMD = Surface Mounted Device**

Dimensions in mm

**P-DSO-20-6**  
(Plastic Dual Small Outline)

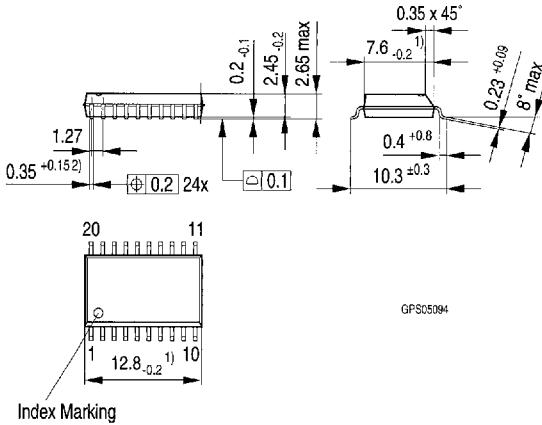

GPS05094

- 1) Does not include plastic or metal protrusions of 0.15 max per side
- 2) Does not include dambar protrusion of 0.05 max per side

**Sorts of Packing**

■ 8235605 0118620 812 ■

Package outlines for tubes, trays etc. are contained in our Data Book "Package Information".

**SMD = Surface Mounted Device**

Dimensions in mm