



**PRELIMINARY**

**CY7C1381BV25  
CY7C1383BV25**

**512K x 36 / 1M x 18 Flow-Thru SRAM**

**Features**

- **Fast access times: 6.5, 7.5, 8.5 ns**
- **Fast clock speed: 133, 117, 100 MHz**
- **Provide high-performance 3-1-1 access rate**
- **Optimal for depth expansion**
- **2.5V (±5%) power supply**
- **Common data inputs and data outputs**
- **Byte Write Enable and Global Write control**
- **Chip enable for address pipeline**
- **Address, data, and control registers**
- **Internally self-timed Write Cycle**
- **Burst control pins (interleaved or linear burst sequence)**
- **Automatic power-down for portable applications**
- **High-density, high-speed packages**

**Functional Description**

The Cypress Synchronous Burst SRAM family employs high-speed, low-power CMOS designs using advanced triple-layer polysilicon, double-layer metal technology. Each memory cell consists of four transistors and two high-valued resistors.

The CY7C1381BV25 and CY7C1383BV25 SRAMs integrate 524,288x36 and 1,048,576x18SRAM cells with advanced synchronous peripheral circuitry and a 2-bit counter for internal burst operation. All synchronous inputs are gated by registers

controlled by a positive-edge-triggered Clock Input (CLK). The synchronous inputs include all addresses, all data inputs, address-pipelining Chip Enable ( $\overline{CE}$ ), Burst Control Inputs ( $\overline{ADSC}$ ,  $\overline{ADSP}$ , and  $\overline{ADV}$ ), Write Enables ( $\overline{BWA}$ ,  $\overline{BWB}$ ,  $\overline{BWC}$ ,  $\overline{BWD}$  and  $\overline{BWE}$ ), and Global Write ( $\overline{GW}$ ).

... Asynchronous inputs include the Output Enable ( $\overline{OE}$ ) and burst mode control (MODE). The data outputs (Q), enabled by  $\overline{OE}$ , are also asynchronous.

Addresses and chip enables are registered with either Address Status Processor (ADSP) or Address Status Controller (ADSC) input pins. Subsequent burst addresses can be internally generated as controlled by the Burst Advance Pin (ADV).

Address, data inputs, and write controls are registered on-chip to initiate self-timed WRITE cycle. WRITE cycles can be one to four bytes wide as controlled by the write control inputs. Individual byte write allows individual byte to be written.  $\overline{BWA}$  controls DQ1–DQ8 and DQP1.  $\overline{BWB}$  controls DQ9–DQ16 and DQP2.  $\overline{BWC}$  controls DQ17–DQ24 and DQP3.  $\overline{BWD}$  controls DQ25–DQ32 and DQP4.  $\overline{BWA}$ ,  $\overline{BWB}$ ,  $\overline{BWC}$ , and  $\overline{BWD}$  can be active only with  $\overline{BWE}$  being LOW.  $\overline{GW}$  being LOW causes all bytes to be written. WRITE pass-through capability allows written data available at the output for the immediately next READ cycle. This device also incorporates pipelined enable circuit for easy depth expansion without penalizing system performance.

All inputs and outputs of the CY7C1381BV25 and the CY7C1383BV25 are JEDEC standard JESD8-5 compatible.

**Selection Guide**

		<b>133 MHz</b>	<b>117 MHz</b>	<b>100 MHz</b>
Maximum Access Time (ns)		6.5	7.5	8.5
Maximum Operating Current (mA)	Commercial	300	250	230
Maximum CMOS Standby Current (mA)		30	30	30

Shaded areas contain advance information.

Functional Block Diagram

Logic Block Diagram x18:

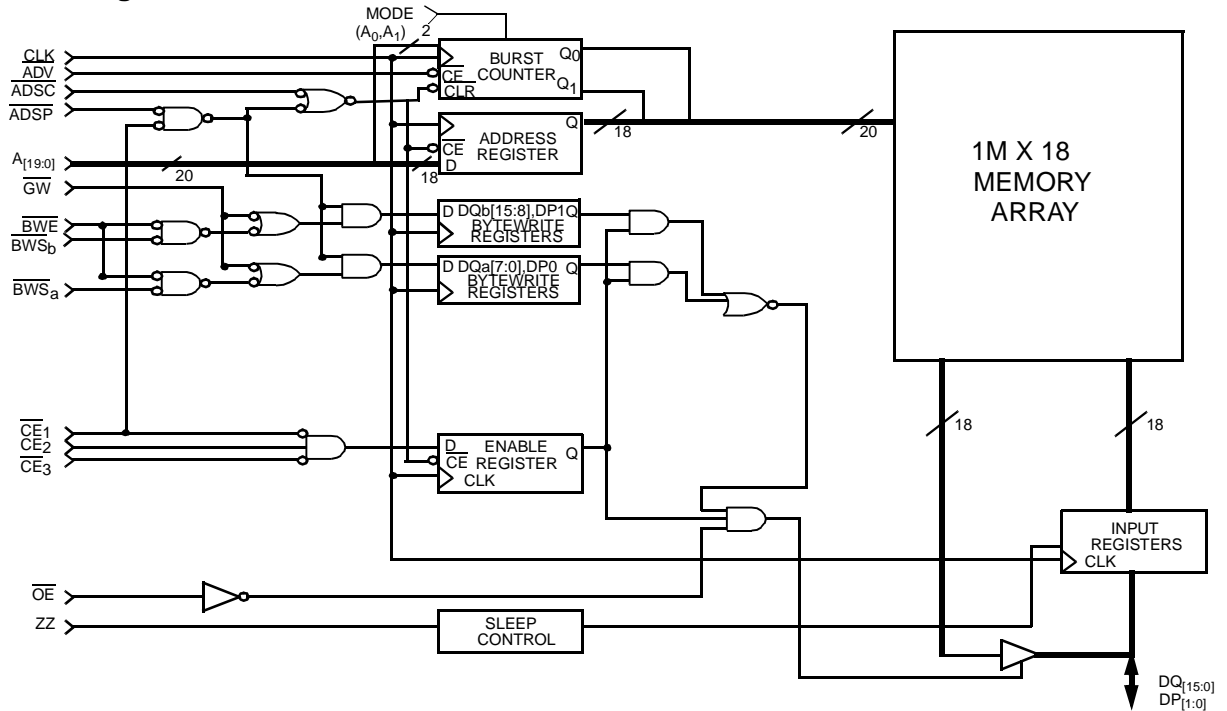

Logic Block Diagram x36:

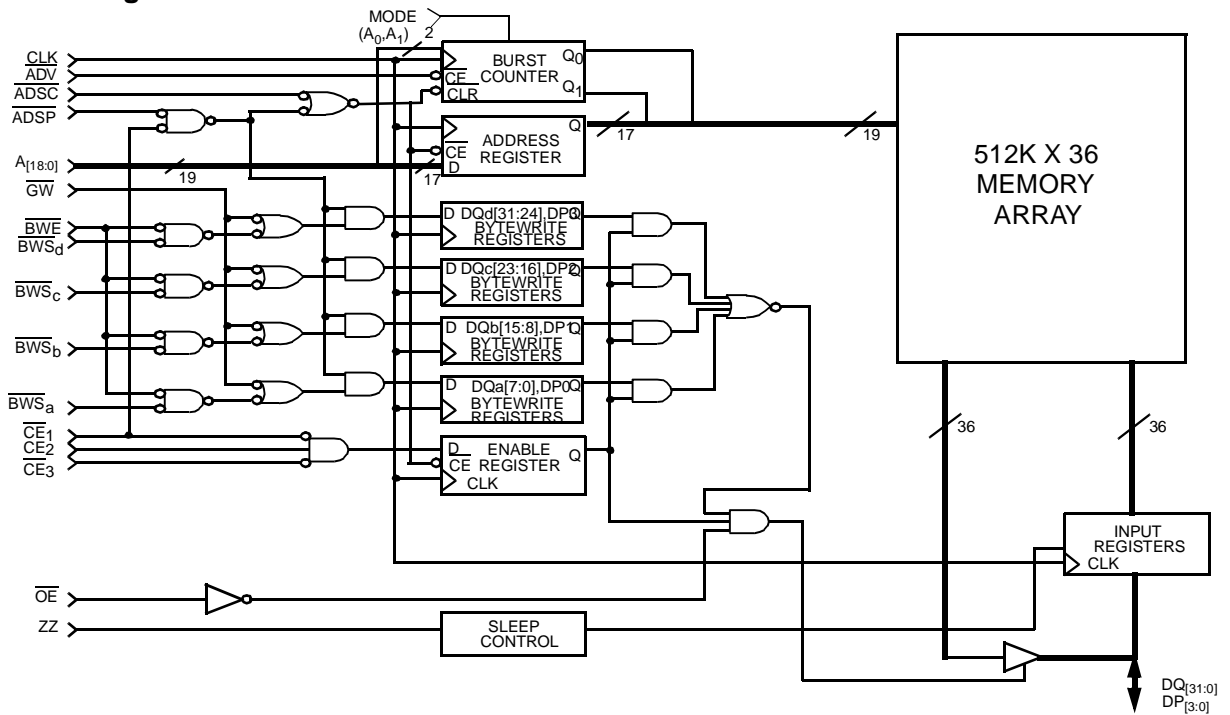

**Pin Configurations**

**100-Pin TQFP**

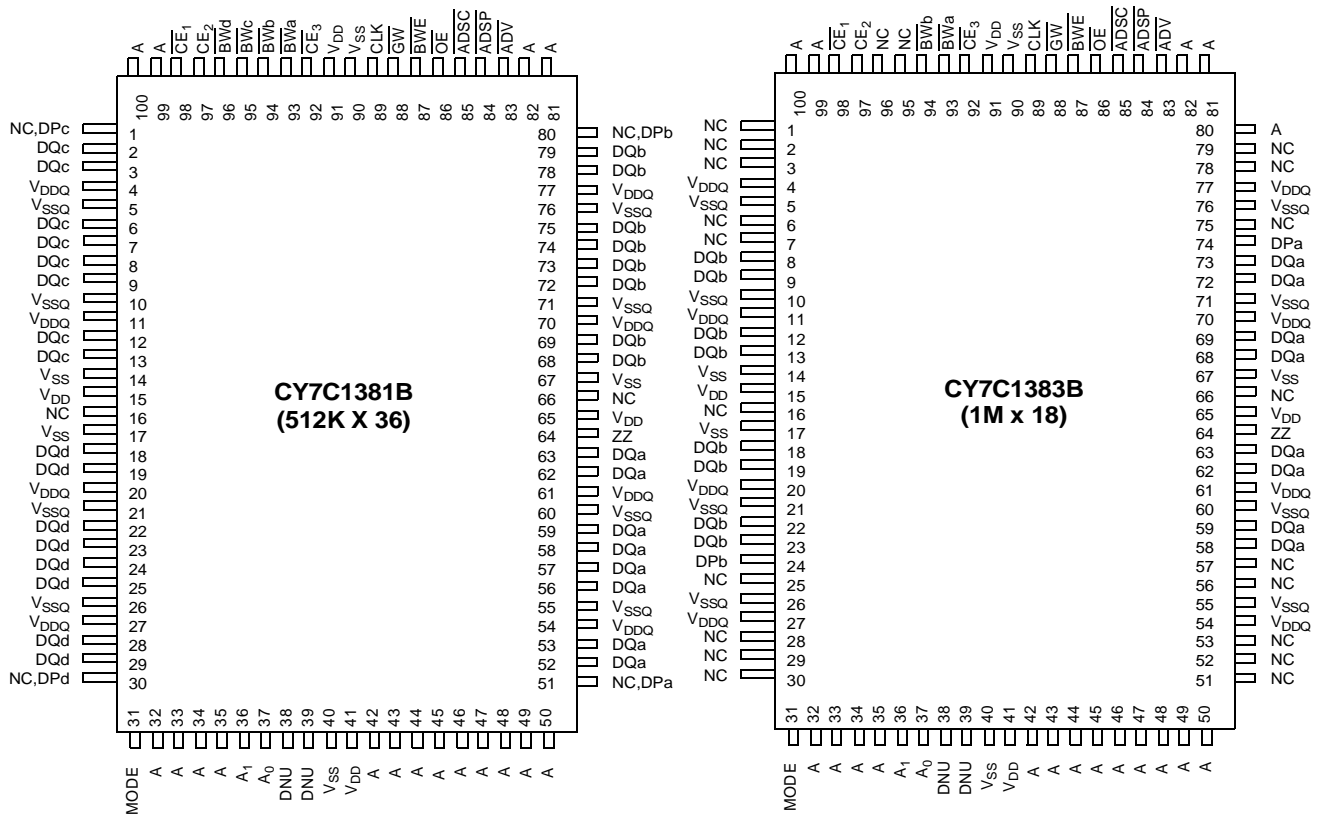

**Pin Configurations** (continued)

**119-Ball BGA  
CY7C1381BV25 (512K x 36)**

	1	2	3	4	5	6	7
<b>A</b>	V <sub>DDQ</sub>	A	A	ADSP	A	A	V <sub>DDQ</sub>
<b>B</b>	NC	A	A	ADSC	A	A	NC
<b>C</b>	NC	A	A	V <sub>DD</sub>	A	A	NC
<b>D</b>	DQc	DQPc	V <sub>SS</sub>	NC	V <sub>SS</sub>	DQPb	DQb
<b>E</b>	DQc	DQc	V <sub>SS</sub>	CE <sub>1</sub>	V <sub>SS</sub>	DQb	DQb
<b>F</b>	V <sub>DDQ</sub>	DQc	V <sub>SS</sub>	OE	V <sub>SS</sub>	DQb	V <sub>DDQ</sub>
<b>G</b>	DQc	DQc	BWc	ADV	BWb	DQb	DQb
<b>H</b>	DQc	DQc	V <sub>SS</sub>	GW	V <sub>SS</sub>	DQb	DQb
<b>J</b>	V <sub>DDQ</sub>	V <sub>DD</sub>	NC	V <sub>DD</sub>	NC	V <sub>DD</sub>	V <sub>DDQ</sub>
<b>K</b>	DQd	DQd	V <sub>SS</sub>	CLK	V <sub>SS</sub>	DQa	DQa
<b>L</b>	DQd	DQd	BWd	NC	BWa	DQa	DQa
<b>M</b>	V <sub>DDQ</sub>	DQd	V <sub>SS</sub>	BWE	V <sub>SS</sub>	DQa	V <sub>DDQ</sub>
<b>N</b>	DQd	DQd	V <sub>SS</sub>	A1	V <sub>SS</sub>	DQa	DQa
<b>P</b>	DQd	DQPd	V <sub>SS</sub>	A0	V <sub>SS</sub>	DQPd	DQa
<b>R</b>	NC	A	MODE	V <sub>DD</sub>	NC	A	NC
<b>T</b>	NC	NC	A	A	A	NC	ZZ
<b>U</b>	V <sub>DDQ</sub>	TMS	TDI	TCK	TDO	NC	V <sub>DDQ</sub>

**CY7C1383BV25 (1M x 18)**

	1	2	3	4	5	6	7
<b>A</b>	V <sub>DDQ</sub>	A	A	ADSP	A	A	V <sub>DDQ</sub>
<b>B</b>	NC	A	A	ADSC	A	A	NC
<b>C</b>	NC	A	A	V <sub>DD</sub>	A	A	NC
<b>D</b>	DQb	NC	V <sub>SS</sub>	NC	V <sub>SS</sub>	DQPd	NC
<b>E</b>	NC	DQb	V <sub>SS</sub>	CE <sub>1</sub>	V <sub>SS</sub>	NC	DQa
<b>F</b>	V <sub>DDQ</sub>	NC	V <sub>SS</sub>	OE	V <sub>SS</sub>	DQa	V <sub>DDQ</sub>
<b>G</b>	NC	DQb	BWb	ADV	V <sub>SS</sub>	NC	DQa
<b>H</b>	DQb	NC	V <sub>SS</sub>	GW	V <sub>SS</sub>	DQb	NC
<b>J</b>	V <sub>DDQ</sub>	V <sub>DD</sub>	NC	V <sub>DD</sub>	NC	V <sub>DD</sub>	V <sub>DDQ</sub>
<b>K</b>	NC	DQb	V <sub>SS</sub>	CLK	V <sub>SS</sub>	NC	DQa
<b>L</b>	DQb	NC	V <sub>SS</sub>	NC	BWa	DQa	NC
<b>M</b>	V <sub>DDQ</sub>	DQb	V <sub>SS</sub>	BWE	V <sub>SS</sub>	NC	V <sub>DDQ</sub>
<b>N</b>	DQb	NC	V <sub>SS</sub>	A1	V <sub>SS</sub>	DQa	NC
<b>P</b>	NC	DQPd	V <sub>SS</sub>	A0	V <sub>SS</sub>	NC	DQa
<b>R</b>	NC	A	MODE	V <sub>DD</sub>	NC	A	NC
<b>T</b>	NC	A	A	NC	A	A	ZZ
<b>U</b>	V <sub>DDQ</sub>	TMS	TDI	TCK	TDO	NC	V <sub>DDQ</sub>

**Pin Definitions**

Name	I/O	Description
A0 A1 A	Input- Synchronous	Address Inputs used to <u>select one of the</u> address locations. <u>Sampled at the rising edge of the CLK</u> if ADSP or ADSC is active LOW, and CE <sub>1</sub> , CE <sub>2</sub> , and CE <sub>3</sub> are sampled active. A <sub>[1:0]</sub> feed the 2-bit counter.
$\overline{BWA}$ $\overline{BWB}$ $\overline{BWC}$ $\overline{BWD}$	Input- Synchronous	Byte Write Select Inputs, active LOW. Qualified with $\overline{BWE}$ to conduct byte writes to the SRAM. Sampled on the rising edge of CLK.
$\overline{GW}$	Input- Synchronous	Global Write Enable Input, active LOW. When asserted LOW on the rising edge of CLK, a <u>global write is conducted</u> (ALL bytes are written, regardless of the values on $\overline{BW}_{a,b,c,d}$ and $\overline{BWE}$ ).
$\overline{BWE}$	Input- Synchronous	Byte Write Enable Input, active LOW. Sampled on the rising edge of CLK. This signal must be asserted LOW to conduct a byte write.
CLK	Input-Clock	Clock Input. Used to capture all synchronous inputs to the device. Also used to increment the burst counter when ADV is asserted LOW, during a burst operation.
$\overline{CE}_1$	Input- Synchronous	Chip Enable 1 Input, active <u>LOW</u> . Sampled on the rising edge of CLK. Used in conjunction with CE <sub>2</sub> and CE <sub>3</sub> to select/deselect the device. ADSP is ignored if $\overline{CE}_1$ is HIGH. (TQFP Only)
CE <sub>2</sub>	Input- Synchronous	Chip Enable 2 Input, active <u>HIGH</u> . Sampled on the rising edge of CLK. Used in conjunction with CE <sub>1</sub> and CE <sub>3</sub> to select/deselect the device. (TQFP Only)
$\overline{CE}_3$	Input- Synchronous	Chip Enable 3 Input, active <u>LOW</u> . Sampled on the rising edge of CLK. Used in conjunction with CE <sub>1</sub> and CE <sub>2</sub> to select/deselect the device.
$\overline{OE}$	Input- Asynchronous	Output Enable, asynchronous input, active LOW. Controls the direction of the I/O pins. When LOW, the I/O pins behave as outputs. <u>When deasserted HIGH</u> , I/O pins are three-stated, and act as input data pins. $\overline{OE}$ is masked during the first clock of a read cycle when emerging from a deselected state.
ADV	Input- Synchronous	Advance Input signal, sampled on the rising edge of CLK. When asserted, it automatically increments the address in a burst cycle.
$\overline{ADSP}$	Input- Synchronous	Address Strobe from Processor, sampled on the rising edge of CLK. When asserted LOW, A is captured <u>in the address registers</u> . A <sub>[1:0]</sub> are also loaded into the burst counter. When $\overline{ADSP}$ and $\overline{ADSC}$ are both asserted, only $\overline{ADSP}$ is recognized. $\overline{ADSP}$ is ignored when CE <sub>1</sub> is deasserted HIGH.
$\overline{ADSC}$	Input- Synchronous	Address Strobe from Controller, sampled on the rising edge of CLK. When asserted LOW, A <sub>[x:0]</sub> is captured <u>in the address registers</u> . A <sub>[1:0]</sub> are also loaded into the burst counter. When $\overline{ADSP}$ and $\overline{ADSC}$ are both asserted, only $\overline{ADSP}$ is recognized.
MODE	Input- Static	Selects burst order. When tied to GND selects linear burst sequence. When tied to V <sub>DDQ</sub> or left floating selects interleaved burst sequence. This is a strap pin and should remain static during device operation.
ZZ	Input- Asynchronous	ZZ "sleep" Input. This active HIGH input places the device in a non-time critical "sleep" condition with data integrity preserved.
DQa, DQPa DQb, DQPb DQc, DQ Pc DQd, DQPd	I/O- Synchronous	Bidirectional Data I/O lines. As inputs, they feed into an on-chip data register that is triggered by the rising edge of CLK. As outputs, they deliver the data contained in the memory location specified by A during the <u>previous clock rise</u> of the read cycle. The direction of the pins is controlled by $\overline{OE}$ . When $\overline{OE}$ is asserted LOW, the pins behave as outputs. When HIGH, DQa–DQd and DQPa–DQPd are placed in a three-state condition.
TDO	JTAG serial output Synchronous	Serial data-out to the JTAG circuit. Delivers data on the negative edge of TCK (BGA Only).
TDI	JTAG serial input Synchronous	Serial data-In to the JTAG circuit. Sampled on the rising edge of TCK (BGA Only).

**Pin Definitions** (continued)

Name	I/O	Description
TMS	Test Mode Select Synchronous	This pin controls the Test Access Port state machine. Sampled on the rising edge of TCK (BGA Only).
TCK	JTAG serial output Synchronous	Serial data-out to the JTAG circuit. Delivers data on the negative edge of TCK (BGA Only).
V <sub>DD</sub>	Power Supply	Power supply inputs to the core of the device. Should be connected to 2.5V power supply.
V <sub>SS</sub>	Ground	Ground for the core of the device. Should be connected to ground of the system.
V <sub>DDQ</sub>	I/O Power Supply	Power supply for the I/O circuitry. Should be connected to a 2.5V power supply.
V <sub>SSQ</sub>	I/O Ground	Ground for the I/O circuitry. Should be connected to ground of the system.
NC	-	No Connects.

**Functional Description**
**Single Read Accesses**

This access is initiated when the following conditions are satisfied at clock rise: (1) ADSP or ADSC is asserted LOW, (2)  $\overline{CE}_1$ ,  $\overline{CE}_2$ ,  $\overline{CE}_3$  are all asserted active, and (3) the write signals (GW, BWE) are all deasserted HIGH. ADSP is ignored if  $\overline{CE}_1$  is HIGH. The address presented to the address inputs is stored into the address advancement logic and the Address Register while being presented to the memory core. If the OE input is asserted LOW, the requested data will be available at the data outputs a maximum of  $t_{CDV}$  after clock rise. ADSP is ignored if  $\overline{CE}_1$  is HIGH.

**Single Write Accesses Initiated by ADSP**

This access is initiated when both of the following conditions are satisfied at clock rise: (1) ADSP is asserted LOW, and (2) chip enable asserted active. The address presented is loaded into the address register and the address advancement logic while being delivered to the RAM core. The write signals (GW, BWE, and BWx) and ADV inputs are ignored during this first clock cycle. If the write inputs are asserted active (see Write Cycle Descriptions table for appropriate states that indicate a write) on the next clock rise, the appropriate data will be latched and written into the device. The CY7C1381BV25/CY7C1383AV25 provides byte write capability that is described in the Write Cycle Description table. Asserting the Byte Write Enable input (BWE) with the selected Byte Write ( $BW_{a,b,c,d}$  for CY7C1381BV25 and  $BW_{a,b}$  for CY7C1383AV25) input will selectively write to only the desired bytes. Bytes not selected during a byte write operation will remain unaltered. All I/Os are three-stated during a byte write.

Because the CY7C1381BV25/CY7C1383AV25 is a common I/O device, the Output Enable (OE) must be deasserted HIGH before presenting data to the DQx inputs. Doing so will three-state the output drivers. As a safety precaution, DQx are automatically three-stated whenever a write cycle is detected, regardless of the state of OE.

**Single Write Accesses Initiated by ADSC**

ADSC write accesses are initiated when the following conditions are satisfied: (1) ADSC is asserted LOW, (2) ADSP is

deasserted HIGH, (3)  $\overline{CE}_1$ ,  $\overline{CE}_2$ ,  $\overline{CE}_3$  are all asserted active, and (4) the appropriate combination of the write inputs (GW, BWE, and BWx) are asserted active to conduct a write to the desired byte(s). ADSC is ignored if ADSP is active LOW.

The address presented to  $A_{[17:0]}$  is loaded into the address register and the address advancement logic while being delivered to the RAM core. The ADV input is ignored during this cycle. If a global write is conducted, the data presented to the DQx is written into the corresponding address location in the RAM core. If a byte write is conducted, only the selected bytes are written. Bytes not selected during a byte write operation will remain unaltered. All I/Os are three-stated during a byte write because the CY7C1381BV25/CY7C1383AV25 is a common I/O device, the Output Enable (OE) must be deasserted HIGH before presenting data to the DQx inputs. Doing so will three-state the output drivers. As a safety precaution, DQx are automatically three-stated whenever a write cycle is detected, regardless of the state of OE.

**Burst Sequences**

The CY7C1381BV25/CY7C1383AV25 provides a two-bit wraparound counter, fed by  $A_{[1:0]}$ , that implements either an interleaved or linear burst sequence, to support processors that follow a linear burst sequence. The burst sequence is user selectable through the MODE input.

Asserting ADV LOW at clock rise will automatically increment the burst counter to the next address in the burst sequence. Both read and write burst operations are supported.

**Interleaved Burst Sequence**

First Address	Second Address	Third Address	Fourth Address
$A_{[1:0]}$	$A_{[1:0]}$	$A_{[1:0]}$	$A_{[1:0]}$
00	01	10	11
01	00	11	10
10	11	00	01
11	10	01	00

**Linear Burst Sequence**

First Address	Second Address	Third Address	Fourth Address
$A_{[1:0]}$	$A_{[1:0]}$	$A_{[1:0]}$	$A_{[1:0]}$
00	01	10	11
01	10	11	00
10	11	00	01
11	00	01	10

**Sleep Mode**

The ZZ input pin is an asynchronous input. Asserting ZZ HIGH places the SRAM in a power conservation “sleep” mode. Two clock cycles are required to enter into or exit from this “sleep” mode. While in this mode, data integrity is guaranteed. Accesses pending when entering the “sleep” mode are not considered valid nor is the completion of the operation guaranteed. The device must be deselected prior to entering the “sleep” mode.  $\overline{CE}_1$ ,  $\overline{CE}_2$ ,  $\overline{CE}_3$ , ADSP, and ADSC must remain inactive for the duration of  $t_{ZZREC}$  after the ZZ input returns LOW. Leaving ZZ unconnected defaults the device into an active state.

**ZZ Mode Electrical Characteristics**

Parameter	Description	Test Conditions	Min.	Max.	Unit
$I_{CCZZ}$	Snooze mode standby current	$ZZ \geq V_{DD} - 0.2V$		15	mA
$t_{ZZS}$	Device operation to ZZ	$ZZ \geq V_{DD} - 0.2V$		$2t_{CYC}$	ns
$t_{ZZREC}$	ZZ recovery time	$ZZ \leq 0.2V$	$2t_{CYC}$		ns





Cycle Descriptions<sup>[1, 2, 3]</sup>

Next Cycle	Add. Used	ZZ	$\overline{CE}_3$	$CE_2$	$\overline{CE}_1$	$\overline{ADSP}$	$\overline{ADSC}$	$\overline{ADV}$	$\overline{OE}$	DQ	Write
Unselected	None	L	X	X	1	X	0	X	X	Hi-Z	X
Unselected	None	L	1	X	0	0	X	X	X	Hi-Z	X
Unselected	None	L	X	0	0	0	X	X	X	Hi-Z	X
Unselected	None	L	1	X	0	1	0	X	X	Hi-Z	X
Unselected	None	L	X	0	0	1	0	X	X	Hi-Z	X
Begin Read	External	L	0	1	0	0	X	X	X	Hi-Z	X
Begin Read	External	L	0	1	0	1	0	X	X	Hi-Z	Read
Continue Read	Next	L	X	X	X	1	1	0	1	Hi-Z	Read
Continue Read	Next	L	X	X	X	1	1	0	0	DQ	Read
Continue Read	Next	L	X	X	1	X	1	0	1	Hi-Z	Read
Continue Read	Next	L	X	X	1	X	1	0	0	DQ	Read
Suspend Read	Current	L	X	X	X	1	1	1	1	Hi-Z	Read
Suspend Read	Current	L	X	X	X	1	1	1	0	DQ	Read
Suspend Read	Current	L	X	X	1	X	1	1	1	Hi-Z	Read
Suspend Read	Current	L	X	X	1	X	1	1	0	DQ	Read
Begin Write	Current	L	X	X	X	1	1	1	X	Hi-Z	Write
Begin Write	Current	L	X	X	1	X	1	1	X	Hi-Z	Write
Begin Write	External	L	0	1	0	1	0	X	X	Hi-Z	Write
Continue Write	Next	L	X	X	X	1	1	0	X	Hi-Z	Write
Continue Write	Next	L	X	X	1	X	1	0	X	Hi-Z	Write
Suspend Write	Current	L	X	X	X	1	1	1	X	Hi-Z	Write
Suspend Write	Current	L	X	X	1	X	1	1	X	Hi-Z	Write
ZZ "sleep"	None	H	X	X	X	X	X	X	X	Hi-Z	X

Notes:

1. X = "Don't Care," 1 = HIGH, 0 = LOW.
2. The SRAM always initiates a read cycle when  $\overline{ADSP}$  asserted, regardless of the state of  $\overline{GW}$ ,  $\overline{BWE}$ , or  $\overline{BWx}$ . Writes may occur only on subsequent clocks after the  $\overline{ADSP}$  or with the assertion of  $\overline{ADSC}$ . As a result,  $\overline{OE}$  must be driven HIGH prior to the start of the write cycle to allow the outputs to three-state.  $\overline{OE}$  is a "Don't Care" for the remainder of the write cycle.
3.  $\overline{OE}$  is asynchronous and is not sampled with the clock rise. It is masked internally during write cycles. During a read cycle DQ = High-Z when  $\overline{OE}$  is inactive or when the device is deselected, and DQ = data when  $\overline{OE}$  is active.

**Write Cycle Description<sup>[1, 2, 3]</sup>**

Function (CY7C1381BV25)	$\overline{GW}$	$\overline{BWE}$	$\overline{BWd}$	$\overline{BWc}$	$\overline{BWb}$	$\overline{BWa}$
Read	1	1	X	X	X	X
Read	1	0	1	1	1	1
Write Byte 0 - DQa	1	0	1	1	1	0
Write Byte 1 - DQb	1	0	1	1	0	1
Write Bytes 1, 0	1	0	1	1	0	0
Write Byte 2 - DQc	1	0	1	0	1	1
Write Bytes 2, 0	1	0	1	0	1	0
Write Bytes 2, 1	1	0	1	0	0	1
Write Bytes 2, 1, 0	1	0	1	0	0	0
Write Byte 3 - DQd	1	0	0	1	1	1
Write Bytes 3, 0	1	0	0	1	1	0
Write Bytes 3, 1	1	0	0	1	0	1
Write Bytes 3, 1, 0	1	0	0	1	0	0
Write Bytes 3, 2	1	0	0	0	1	1
Write Bytes 3, 2, 0	1	0	0	0	1	0
Write Bytes 3, 2, 1	1	0	0	0	0	1
Write All Bytes	1	0	0	0	0	0
Write All Bytes	0	X	X	X	X	X

Function (CY7C1383AV25)	$\overline{GW}$	$\overline{BWE}$	$\overline{BWb}$	$\overline{BWa}$
Read	1	1	X	X
Read	1	0	1	1
Write Byte 0 - DQ <sub>a</sub> and DP <sub>a</sub>	1	0	1	0
Write Byte 1 - DQ <sub>b</sub> and DP <sub>b</sub>	1	0	0	1
Write All Bytes	1	0	0	0
Write All Bytes	0	X	X	X

## IEEE 1149.1 Serial Boundary Scan (JTAG)

The CY7C1381BV25/CY7C1383AV25 incorporates a serial boundary scan Test Access Port (TAP) in the FBGA package only. The TQFP package does not offer this functionality. This port operates in accordance with IEEE Standard 1149.1-1900, but does not have the set of functions required for full 1149.1 compliance. These functions from the IEEE specification are excluded because their inclusion places an added delay in the critical speed path of the SRAM. Note that the TAP controller functions in a manner that does not conflict with the operation of other devices using 1149.1 fully compliant TAPs. The TAP operates using JEDEC standard 2.5V I/O logic levels.

### Disabling the JTAG Feature

It is possible to operate the SRAM without using the JTAG feature. To disable the TAP controller, TCK must be tied LOW ( $V_{SS}$ ) to prevent clocking of the device. TDI and TMS are internally pulled up and may be unconnected. They may alternately be connected to  $V_{DD}$  through a pull-up resistor. TDO should be left unconnected. Upon power-up, the device will come up in a reset state which will not interfere with the operation of the device.

### Test Access Port (TAP) - Test Clock

The test clock is used only with the TAP controller. All inputs are captured on the rising edge of TCK. All outputs are driven from the falling edge of TCK.

### Test Mode Select

The TMS input is used to give commands to the TAP controller and is sampled on the rising edge of TCK. It is allowable to leave this pin unconnected if the TAP is not used. The pin is pulled up internally, resulting in a logic HIGH level.

### Test Data-In (TDI)

The TDI pin is used to serially input information into the registers and can be connected to the input of any of the registers. The register between TDI and TDO is chosen by the instruction that is loaded into the TAP instruction register. For information on loading the instruction register, see the TAP Controller State Diagram. TDI is internally pulled up and can be unconnected if the TAP is unused in an application. TDI is connected to the Most Significant Bit (MSB) on any register.

### Test Data Out (TDO)

The TDO output pin is used to serially clock data-out from the registers. The output is active depending upon the current state of the TAP state machine (see TAP Controller State Diagram). The output changes on the falling edge of TCK. TDO is connected to the Least Significant Bit (LSB) of any register.

### Performing a TAP Reset

A Reset is performed by forcing TMS HIGH ( $V_{DD}$ ) for five rising edges of TCK. This RESET does not affect the operation of the SRAM and may be performed while the SRAM is operating. At power-up, the TAP is reset internally to ensure that TDO comes up in a high-Z state.

### TAP Registers

Registers are connected between the TDI and TDO pins and allow data to be scanned into and out of the SRAM test circuit-

ry. Only one register can be selected at a time through the instruction registers. Data is serially loaded into the TDI pin on the rising edge of TCK. Data is output on the TDO pin on the falling edge of TCK.

#### Instruction Register

Three-bit instructions can be serially loaded into the instruction register. This register is loaded when it is placed between the TDI and TDO pins as shown in the TAP Controller Block Diagram. Upon power-up, the instruction register is loaded with the IDCODE instruction. It is also loaded with the IDCODE instruction if the controller is placed in a reset state as described in the previous section.

When the TAP controller is in the CaptureIR state, the two least significant bits are loaded with a binary "01" pattern to allow for fault isolation of the board level serial test path.

#### Bypass Register

To save time when serially shifting data through registers, it is sometimes advantageous to skip certain states. The bypass register is a single-bit register that can be placed between TDI and TDO pins. This allows data to be shifted through the SRAM with minimal delay. The bypass register is set LOW ( $V_{SS}$ ) when the BYPASS instruction is executed.

#### Boundary Scan Register

The boundary scan register is connected to all the input and output pins on the SRAM. Several no connect (NC) pins are also included in the scan register to reserve pins for higher density devices. The x36 configuration has a xx-bit-long register, and the x18 configuration has a yy-bit-long register.

The boundary scan register is loaded with the contents of the RAM Input and Output ring when the TAP controller is in the Capture-DR state and is then placed between the TDI and TDO pins when the controller is moved to the Shift-DR state. The EXTEST, SAMPLE/PRELOAD and SAMPLE Z instructions can be used to capture the contents of the Input and Output ring.

The Boundary Scan Order tables show the order in which the bits are connected. Each bit corresponds to one of the bumps on the SRAM package. The MSB of the register is connected to TDI, and the LSB is connected to TDO.

#### Identification (ID) Register

The ID register is loaded with a vendor-specific, 32-bit code during the Capture-DR state when the IDCODE command is loaded in the instruction register. The IDCODE is hardwired into the SRAM and can be shifted out when the TAP controller is in the Shift-DR state. The ID register has a vendor code and other information described in the Identification Register Definitions table.

### TAP Instruction Set

Eight different instructions are possible with the three-bit instruction register. All combinations are listed in the Instruction Code table. Three of these instructions are listed as RESERVED and should not be used. The other five instructions are described in detail below.

The TAP controller used in this SRAM is not fully compliant to the 1149.1 convention because some of the mandatory 1149.1 instructions are not fully implemented. The TAP controller cannot be used to load address, data or control signals into the

SRAM and cannot preload the Input or Output buffers. The SRAM does not implement the 1149.1 commands EXTEST or INTEST or the PRELOAD portion of SAMPLE / PRELOAD; rather it performs a capture of the Inputs and Output ring when these instructions are executed.

Instructions are loaded into the TAP controller during the Shift-IR state when the instruction register is placed between TDI and TDO. During this state, instructions are shifted through the instruction register through the TDI and TDO pins. To execute the instruction once it is shifted in, the TAP controller needs to be moved into the Update-IR state.

#### EXTEST

EXTEST is a mandatory 1149.1 instruction which is to be executed whenever the instruction register is loaded with all 0s. EXTEST is not implemented in the TAP controller, and therefore this device is not compliant to the 1149.1 standard.

The TAP controller does not recognize an all-0 instruction. When an EXTEST instruction is loaded into the instruction register, the SRAM responds as if a SAMPLE / PRELOAD instruction has been loaded. There is one difference between the two instructions. Unlike the SAMPLE / PRELOAD instruction, EXTEST places the SRAM outputs in a High-Z state.

#### IDCODE

The IDCODE instruction causes a vendor-specific, 32-bit code to be loaded into the instruction register. It also places the instruction register between the TDI and TDO pins and allows the IDCODE to be shifted out of the device when the TAP controller enters the Shift-DR state. The IDCODE instruction is loaded into the instruction register upon power-up or whenever the TAP controller is given a test logic reset state.

#### SAMPLE Z

The SAMPLE Z instruction causes the boundary scan register to be connected between the TDI and TDO pins when the TAP controller is in a Shift-DR state. It also places all SRAM outputs into a High-Z state.

#### SAMPLE / PRELOAD

SAMPLE / PRELOAD is a 1149.1 mandatory instruction. The PRELOAD portion of this instruction is not implemented, so the TAP controller is not fully 1149.1 compliant.

When the SAMPLE / PRELOAD instructions loaded into the instruction register and the TAP controller in the Capture-DR state, a snapshot of data on the inputs and output pins is captured in the boundary scan register.

The user must be aware that the TAP controller clock can only operate at a frequency up to 10 MHz, while the SRAM clock operates more than an order of magnitude faster. Because there is a large difference in the clock frequencies, it is possible that during the Capture-DR state, an input or output will undergo a transition. The TAP may then try to capture a signal while in transition (metastable state). This will not harm the device, but there is no guarantee as to the value that will be captured. Repeatable results may not be possible.

To guarantee that the boundary scan register will capture the correct value of a signal, the SRAM signal must be stabilized long enough to meet the TAP controller's capture set-up plus hold times ( $t_{CS}$  and  $t_{CH}$ ). The SRAM clock input might not be captured correctly if there is no way in a design to stop (or slow) the clock during a SAMPLE / PRELOAD instruction. If this is an issue, it is still possible to capture all other signals and simply ignore the value of the CK and CK captured in the boundary scan register.

Once the data is captured, it is possible to shift out the data by putting the TAP into the Shift-DR state. This places the boundary scan register between the TDI and TDO pins.

Note that since the PRELOAD part of the command is not implemented, putting the TAP into the Update to the Update-DR state while performing a SAMPLE / PRELOAD instruction will have the same effect as the Pause-DR command.

#### Bypass

When the BYPASS instruction is loaded in the instruction register and the TAP is placed in a Shift-DR state, the bypass register is placed between the TDI and TDO pins. The advantage of the BYPASS instruction is that it shortens the boundary scan path when multiple devices are connected together on a board.

#### Reserved

These instructions are not implemented but are reserved for future use. Do not use these instructions.

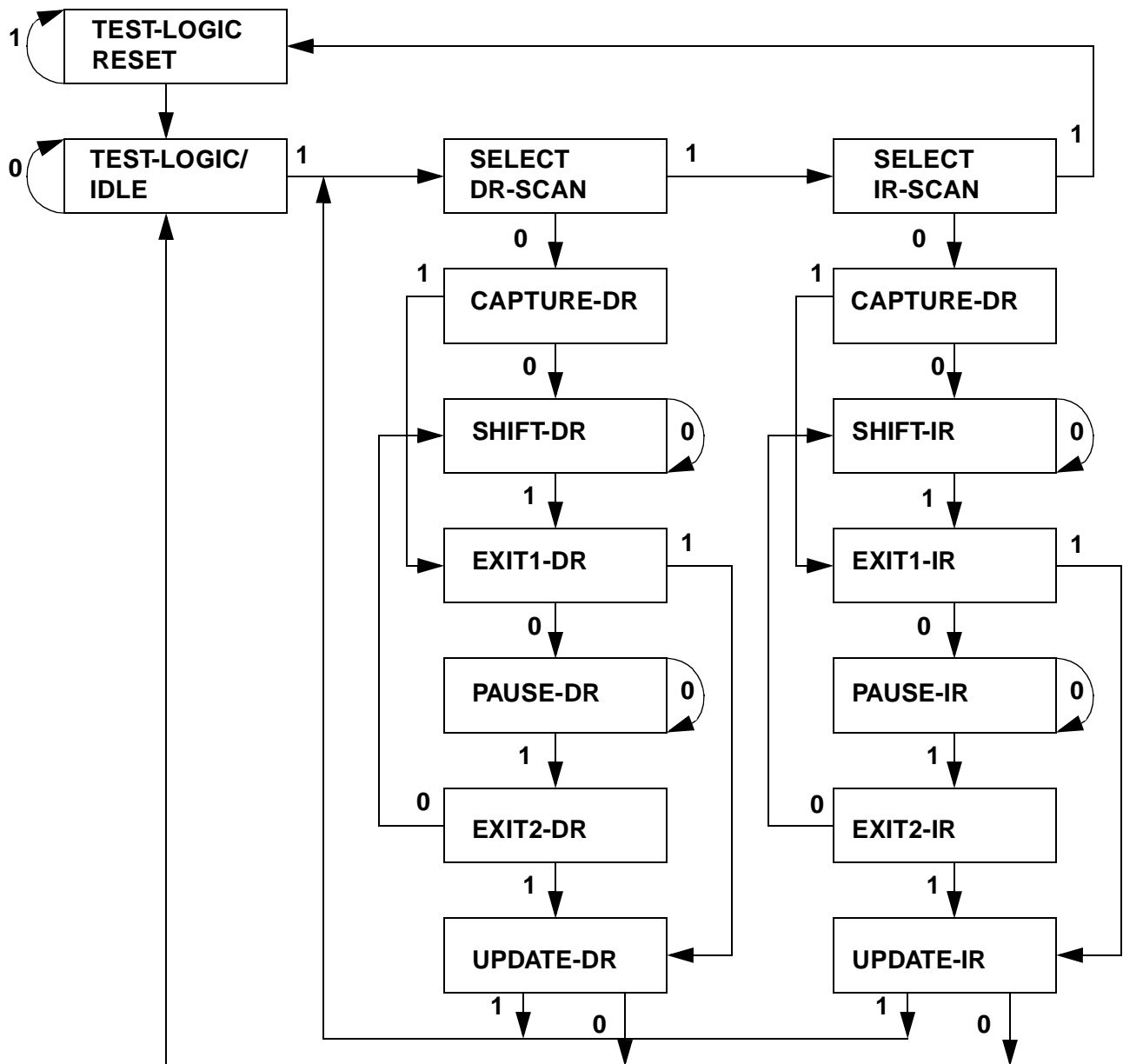
**TAP Controller State Diagram**

Note: The 0/1 next to each state represents the value at TMS at the rising edge of TCK.

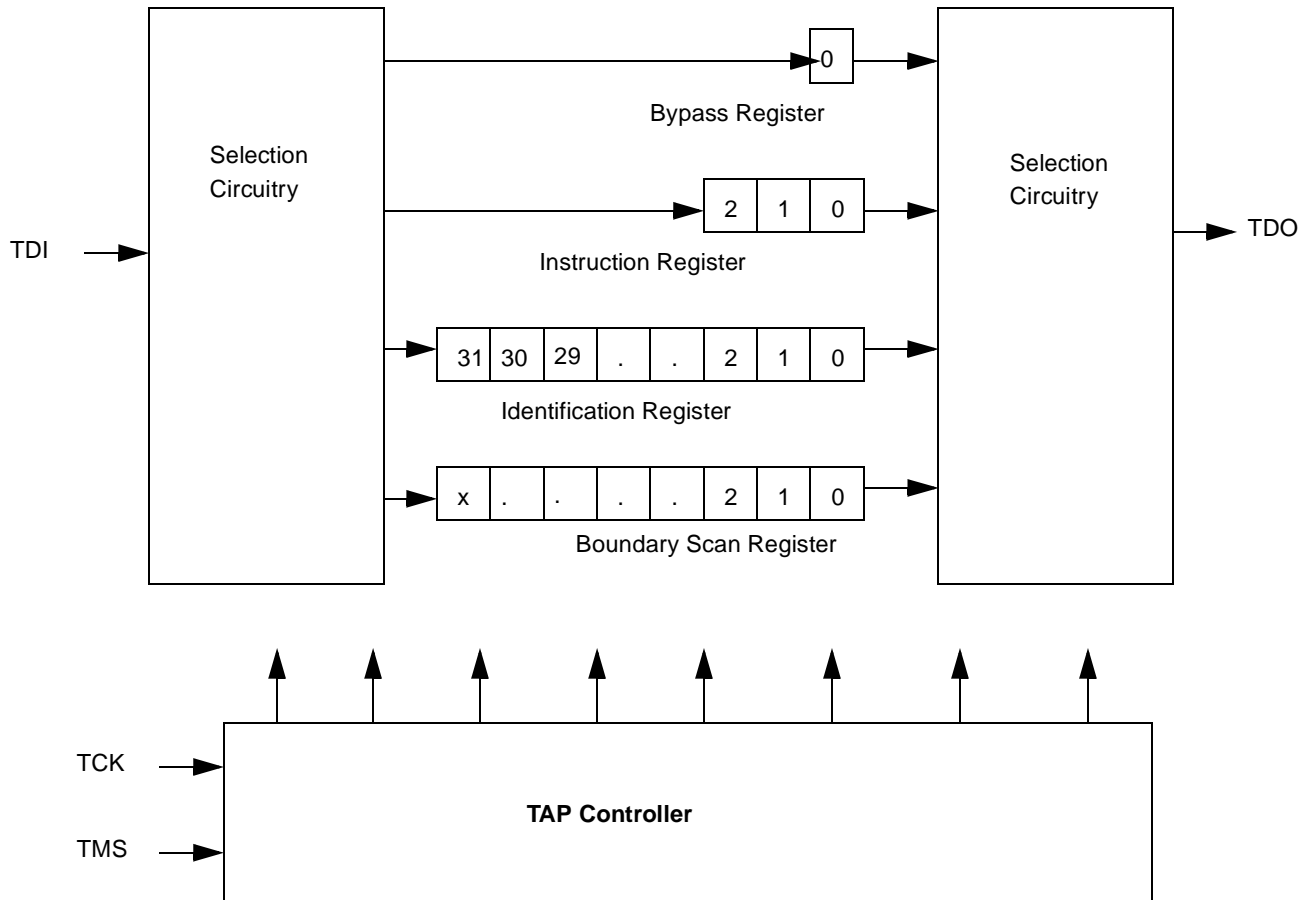
**TAP Controller Block Diagram**

**TAP Electrical Characteristics** Over the Operating Range<sup>[4, 5]</sup>

Parameter	Description	Test Conditions	Min.	Max.	Unit
V <sub>OH1</sub>	Output HIGH Voltage	I <sub>OH</sub> = -2.0 mA	1.7		V
V <sub>OH2</sub>	Output HIGH Voltage	I <sub>OH</sub> = -100 mA	2.1		V
V <sub>OL1</sub>	Output LOW Voltage	I <sub>OL</sub> = 2.0 mA		0.7	V
V <sub>OL2</sub>	Output LOW Voltage	I <sub>OL</sub> = 100 mA		0.2	V
V <sub>IH</sub>	Input HIGH Voltage		1.7	V <sub>DD</sub> +0.3	V
V <sub>IL</sub>	Input LOW Voltage		-0.3	0.7	V
I <sub>X</sub>	Input Load Current	GND ≤ V <sub>I</sub> ≤ V <sub>DDQ</sub>	-5	5	mA

**Notes:**

- All Voltage referenced to Ground.
- Overshoot: V<sub>IH(AC)</sub> ≤ V<sub>DD</sub>+1.5V for t<sub>≤t<sub>TCYC</sub>/2</sub>. Undershoot: V<sub>IL(AC)</sub> ≤ 0.5V for t<sub>≤t<sub>TCYC</sub>/2</sub>. Power-up: V<sub>IH</sub> < 2.6V and V<sub>DD</sub> < 2.4V and V<sub>DDQ</sub> < 1.4V for t < 200 ms.

**TAP AC Switching Characteristics** Over the Operating Range<sup>[6, 7]</sup>

Parameters	Description	Min.	Max.	Unit
$t_{TCYC}$	TCK Clock Cycle Time	100		ns
$t_{TF}$	TCK Clock Frequency		10	MHz
$t_{TH}$	TCK Clock HIGH	40		ns
$t_{TL}$	TCK Clock LOW	40		ns
<b>Set-up Times</b>				
$t_{TMSS}$	TMS Set-up to TCK Clock Rise	10		ns
$t_{TDIS}$	TDI Set-up to TCK Clock Rise	10		ns
$t_{CS}$	Capture Set-up to TCK Rise	10		ns
<b>Hold Times</b>				
$t_{TMSH}$	TMS Hold after TCK Clock Rise	10		ns
$t_{TDIH}$	TDI Hold after Clock Rise	10		ns
$t_{CH}$	Capture Hold after Clock Rise	10		ns
<b>Output Times</b>				
$t_{TDOV}$	TCK Clock LOW to TDO Valid		20	ns
$t_{TDOX}$	TCK Clock LOW to TDO Invalid	0		ns

**Notes:**

6.  $t_{CS}$  and  $t_{CH}$  refer to the set-up and hold time requirements of latching data from the boundary scan register.
7. Test conditions are specified using the load in TAP AC test conditions.  $T_R/T_F = 1$  ns.

**TAP Timing and Test Conditions**

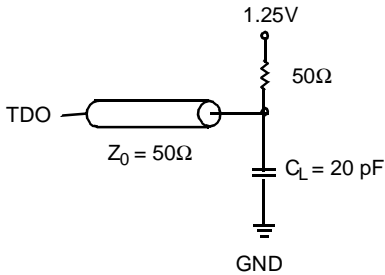

(a)

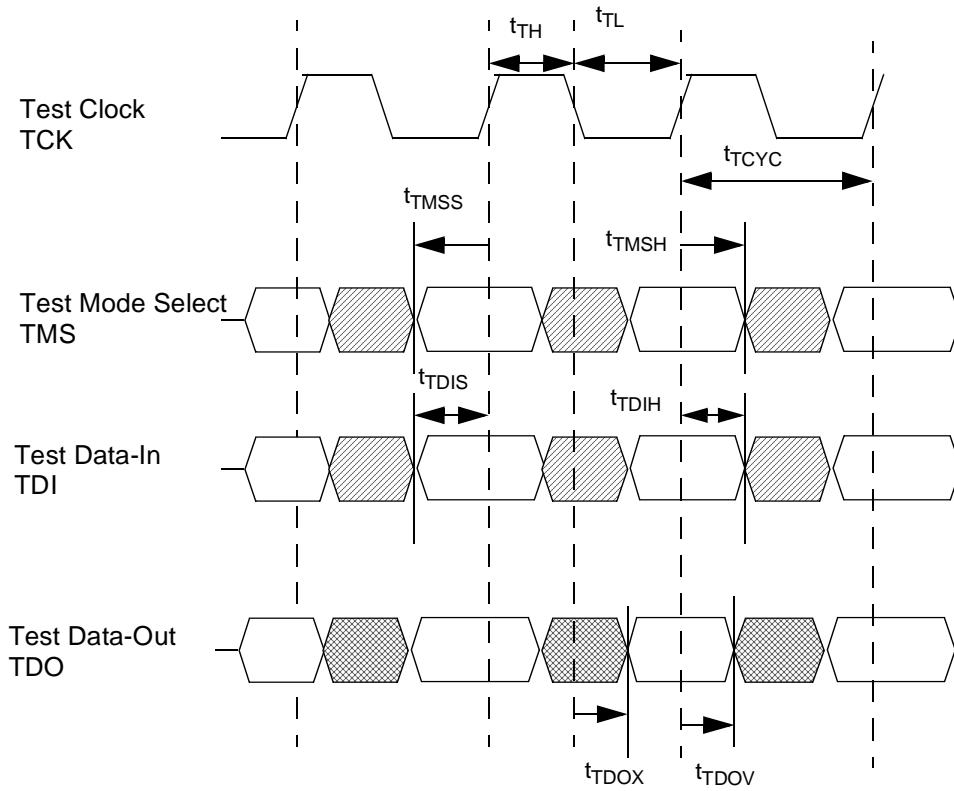
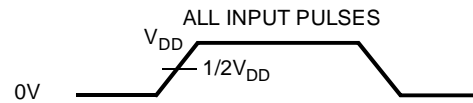



**Identification Register Definitions**

Instruction Field	512K x 36	1M x 18	Description
Revision Number (31:28)	xxxx	xxxx	Reserved for version number.
Device Depth (27:23)	00111	01000	Defines depth of SRAM. 512K or 1M
Device Width (22:18)	00100	00011	Defines with of the SRAM. x36 or x18
Cypress Device ID (17:12)	xxxxx	xxxxx	Reserved for future use.
Cypress JEDEC ID (11:1)	00011100100	00011100100	Allows unique identification of SRAM vendor.
ID Register Presence (0)	1	1	Indicate the presence of an ID register.

**Scan Register Sizes**

Register Name	Bit Size (x18)	Bit Size (x36)
Instruction	3	3
Bypass	1	1
ID	32	32
Boundary Scan	70	51

**Identification Codes**

Instruction	Code	Description
EXTEST	000	Captures the Input/Output ring contents. Places the boundary scan register between the TDI and TDO. Forces all SRAM outputs to High-Z state. This instruction is not 1149.1 compliant.
IDCODE	001	Loads the ID register with the vendor ID code and places the register between TDI and TDO. This operation does not affect SRAM operation.
SAMPLE Z	010	Captures the Input/Output contents. Places the boundary scan register between TDI and TDO. Forces all SRAM output drivers to a High-Z state.
RESERVED	011	Do Not Use: This instruction is reserved for future use.
SAMPLE/PRELOAD	100	Captures the Input/Output ring contents. Places the boundary scan register between TDI and TDO. Does not affect the SRAM operation. This instruction does not implement 1149.1 preload function and is therefore not 1149.1 compliant.
RESERVED	101	Do Not Use: This instruction is reserved for future use.
RESERVED	110	Do Not Use: This instruction is reserved for future use.
BYPASS	111	Places the bypass register between TDI and TDO. This operation does not affect SRAM operation.

**Boundary Scan Order (512K X 18)**

Bit #	Signal Name	Bump ID	Bit #	Signal Name	Bump ID
1	A	2R	36	A	6B
2	A	3T	37	$\overline{BWA}$	5L
3	A	4T	38	$\overline{BWb}$	5G
4	A	5T	39	$\overline{BWc}$	3G
5	A	6R	40	$\overline{BWd}$	3L
6	A	3B	41	A	2B
7	A	5B	42	$\overline{CE}$	4E
8	DQa	6P	43	A	3A
9	DQa	7N	44	A	2A
10	DQa	6M	45	DQc	2D
11	DQa	7L	46	DQc	1E
12	DQa	6K	47	DQc	2F
13	DQa	7P	48	DQc	1G
14	DQa	6N	49	DQc	1D
15	DQa	6L	50	DQc	1D
16	DQa	7K	51	DQc	2E
17	ZZ	7T	52	DQc	2G
18	DQb	6H	53	DQc	1H
19	DQb	7G	54	NC	5R
20	DQb	6F	55	DQd	2K
21	DQb	7E	56	DQd	1L
22	DQb	6D	57	DQd	2M
23	DQb	7H	58	DQd	1N
24	DQb	6G	59	DQd	2P
25	DQb	6E	60	DQd	1K
26	DQb	7D	61	DQd	2L
27	A	6A	62	DQd	2N
28	A	5A	63	DQd	1P
29	$\overline{ADV}$	4G	64	MODE	3R
30	$\overline{ADSP}$	4A	65	A	2C
31	$\overline{ADSC}$	4B	66	A	3C
32	$\overline{OE}$	4F	67	A	5C
33	$\overline{BWE}$	4M	68	A	6C
34	$\overline{GW}$	4H	69	A1	4N
35	CLK	4K	70	A0	4P

**Boundary Scan Order (1M X 18)**

Bit #	Signal Name	Bump ID	Bit #	Signal Name	Bump ID
1	A	2R	36	DQb	2E
2	A	2T	37	DQb	2G
3	A	3T	38	DQb	1H
4	A	5T	39	NC	5R
5	A	6R	40	DQb	2K
6	A	3B	41	DQb	1L
7	A	5B	42	DQb	2M
8	DQa	7P	43	DQb	1N
9	DQa	6N	44	DQb	2P
10	DQa	6L	45	MODE	3R
11	DQa	7K	46	A	2C
12	ZZ	7T	47	A	3C
13	DQa	6H	48	A	5C
14	DQa	7G	49	A	6C
15	DQa	6F	50	A1	4N
16	DQa	7E	51	A0	4P
17	DQa	6D			
18	A	6T			
19	A	6A			
20	A	5A			
21	$\overline{ADV}$	4G			
22	$\overline{ADSP}$	4A			
23	$\overline{ADSC}$	4B			
24	$\overline{OE}$	4F			
25	$\overline{BWE}$	4M			
26	$\overline{GW}$	4H			
27	CLK	4K			
28	A	6B			
29	$\overline{BWA}$	5L			
30	$\overline{BWb}$	3G			
31	A	2B			
32	$\overline{CE}$	4E			
33	A	3A			
34	A	2A			
35	DQb	1D			



**PRELIMINARY**

**CY7C1381BV25  
CY7C1383BV25**

**Maximum Ratings**

(Above which the useful life may be impaired. For user guidelines, not tested.)

Storage Temperature ..... -65°C to +150°C  
 Ambient Temperature with Power Applied ..... -55°C to +125°C  
 Supply Voltage on V<sub>DD</sub> Relative to GND ..... -0.3V to +4.6V  
 DC Voltage Applied to Outputs in High Z State<sup>[8]</sup> ..... -0.5V to V<sub>DDQ</sub> + 0.5V  
 DC Input Voltage<sup>[8]</sup> ..... -0.5V to V<sub>DDQ</sub> + 0.5V

Current into Outputs (LOW)..... 20 mA  
 Static Discharge Voltage ..... >2001V (per MIL-STD-883, Method 3015)  
 Latch-Up Current..... >200 mA

**Operating Range**

Range	Ambient Temp. <sup>[9]</sup>	V <sub>DD</sub> /V <sub>DDQ</sub>
Com'l	0–70°C	2.375V–2.625V/ 2.375V–V <sub>DD</sub>

**Electrical Characteristics** Over the Operating Range

Parameter	Description	Test Conditions	Min.	Max.	Unit	
V <sub>DD</sub>	Power Supply Voltage		2.375	2.625	V	
V <sub>DDQ</sub>	I/O Supply Voltage		2.375	V <sub>DD</sub>	V	
V <sub>OH</sub>	Output HIGH Voltage	V <sub>DD</sub> = Min., I <sub>OH</sub> = -1.0 mA	2.4		V	
V <sub>OL</sub>	Output LOW Voltage	V <sub>DD</sub> = Min., I <sub>OL</sub> = 1.0 mA		0.4	V	
V <sub>IH</sub>	Input HIGH Voltage		2.0		V	
V <sub>IL</sub>	Input LOW Voltage <sup>[8]</sup>		-0.3	0.8	V	
I <sub>X</sub>	Input Load Current except ZZ and MODE	GND ≤ V <sub>I</sub> ≤ V <sub>DDQ</sub>	-5	5	μA	
I <sub>ZZ</sub>	Input Current of MODE		-30	30	μA	
	Input Current of ZZ	Input = V <sub>SS</sub>	-5		μA	
I <sub>OZ</sub>	Output Leakage Current	GND ≤ V <sub>I</sub> ≤ V <sub>DDQ</sub> , Output Disabled	-2	2	μA	
I <sub>DD</sub>	V <sub>DD</sub> Operating Supply Current	V <sub>DD</sub> = Max., I <sub>OUT</sub> = 0 mA, f = f <sub>MAX</sub> = 1/t <sub>CYC</sub>	7.5-ns cycle, 133 MHz		300	mA
			8.5-ns cycle, 117 MHz		250	mA
			10-ns cycle, 100 MHz		230	mA
I <sub>SB1</sub>	Automatic CS Power-Down Current—TTL Inputs	Max. V <sub>DD</sub> , Device Deselected, V <sub>IN</sub> ≥ V <sub>IH</sub> or V <sub>IN</sub> ≤ V <sub>IL</sub> , f = f <sub>MAX</sub> = 1/t <sub>CYC</sub>	7.5-ns cycle, 133 MHz			mA
			8.5-ns cycle, 117 MHz		90	mA
			10-ns cycle, 100 MHz		80	mA
I <sub>SB2</sub>	Automatic CS Power-Down Current—CMOS Inputs	Max. V <sub>DD</sub> , Device Deselected, V <sub>IN</sub> ≤ 0.3V or V <sub>IN</sub> ≥ V <sub>DDQ</sub> - 0.3V, f = 0	All Speeds		30	mA
I <sub>SB3</sub>	Automatic CS Power-Down Current—CMOS Inputs	Max. V <sub>DD</sub> , Device Deselected, or V <sub>IN</sub> ≤ 0.3V or V <sub>IN</sub> ≥ V <sub>DDQ</sub> - 0.3V, f = f <sub>MAX</sub> = 1/t <sub>CYC</sub>	7.5-ns cycle, 133 MHz			mA
			8.5-ns cycle, 117 MHz		80	mA
			10-ns cycle, 100 MHz		70	mA
I <sub>SB4</sub>	Automatic CS Power-Down Current—TTL Inputs	Max. V <sub>DD</sub> , Device Deselected, V <sub>IN</sub> ≥ V <sub>IH</sub> or V <sub>IN</sub> ≤ V <sub>IL</sub> , f = 0	All Speeds		40	mA

Shaded Areas contain advance information.

**Notes:**

- 8. Minimum voltage equals -2.0V for pulse durations of less than 20 ns.
- 9. T<sub>A</sub> is the temperature.

**Capacitance<sup>[10]</sup>**

Parameter	Description	Test Conditions	Max.	Unit
$C_{IN}$	Input Capacitance	$T_A = 25^\circ\text{C}$ , $f = 1\text{ MHz}$ , $V_{DD} = 3.3\text{V}$ , $V_{DDQ} = 2.5\text{V}$	5	pF
$C_{CLK}$	Clock Input Capacitance		4	pF
$C_{I/O}$	Input/Output Capacitance		8	pF

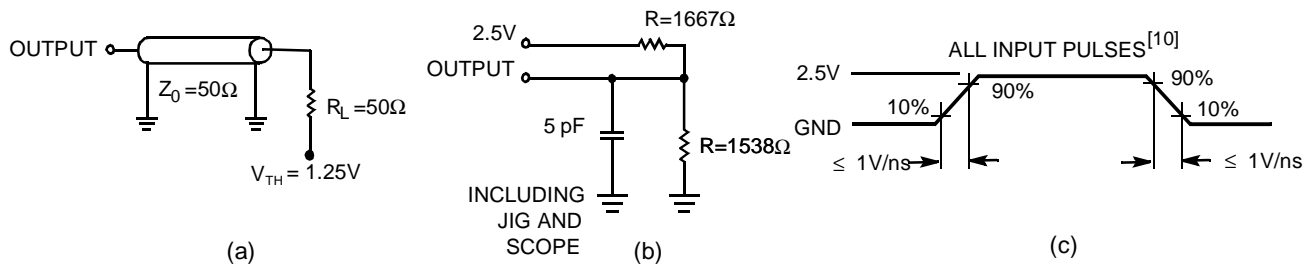
**AC Test Loads and Waveforms<sup>[11]</sup>**

**Notes:**

- 10. Tested initially and after any design or process changes that may affect these parameters.
- 11. Input waveform should have a slew rate of 1 V/ns.

**Switching Characteristics** Over the Operating Range<sup>[12, 13, 14]</sup>

Parameter	Description	-133		-117		-100		Unit
		Min.	Max.	Min.	Max.	Min.	Max.	
t <sub>CYC</sub>	Clock Cycle Time	7.5		8.5		10.0		ns
t <sub>CH</sub>	Clock HIGH	3.0		3.0		3.0		ns
t <sub>CL</sub>	Clock LOW	3.0		3.0		3.0		ns
t <sub>AS</sub>	Address Set-Up Before CLK Rise	2.0		2.0		2.0		ns
t <sub>AH</sub>	Address Hold After CLK Rise	0.5		0.5		0.5		ns
t <sub>CO</sub>	Data Output Valid After CLK Rise		7.0		7.5		8.5	ns
t <sub>DOH</sub>	Data Output Hold After CLK Rise	1.5		1.5		1.5		ns
t <sub>ADS</sub>	$\overline{ADSP}$ , $\overline{ADSC}$ Set-Up Before CLK Rise	2.0		2.0		2.0		ns
t <sub>ADH</sub>	$\overline{ADSP}$ , $\overline{ADSC}$ Hold After CLK Rise	0.5		0.5		0.5		ns
t <sub>WES</sub>	$\overline{BWE}$ , $\overline{GW}$ , $\overline{BW}_x$ Set-Up Before CLK Rise	2.0		2.0		2.0		ns
t <sub>WEH</sub>	$\overline{BWE}$ , $\overline{GW}$ , $\overline{BW}_x$ Hold After CLK Rise	0.5		0.5		0.5		ns
t <sub>ADVS</sub>	$\overline{ADV}$ Set-Up Before CLK Rise	2.0		2.0		2.0		ns
t <sub>ADVH</sub>	$\overline{ADV}$ Hold After CLK Rise	0.5		0.5		0.5		ns
t <sub>DS</sub>	Data Input Set-Up Before CLK Rise	2.0		2.0		2.0		ns
t <sub>DH</sub>	Data Input Hold After CLK Rise	0.5		0.5		0.5		ns
t <sub>CES</sub>	Chip enable Set-Up	2.0		2.0		2.0		ns
t <sub>CEH</sub>	Chip enable Hold After CLK Rise	0.5		0.5		0.5		ns
t <sub>CHZ</sub>	Clock to High-Z <sup>[13]</sup>	0	4.0	0	4.0	0	5.0	ns
t <sub>CLZ</sub>	Clock to Low-Z <sup>[13]</sup>	0		0		0		ns
t <sub>EOHZ</sub>	$\overline{OE}$ HIGH to Output High-Z <sup>[13, 14]</sup>		3.5		3.5		4.0	ns
t <sub>EOLZ</sub>	$\overline{OE}$ LOW to Output Low-Z <sup>[13, 14]</sup>	0		0		0		ns
t <sub>EOV</sub>	$\overline{OE}$ LOW to Output Valid <sup>[13]</sup>		3.5		3.5		4.0	ns

Shaded areas contain advance information.

**Notes:**

- Unless otherwise noted, test conditions assume signal transition time of 2.5 ns or less, timing reference levels of 1.25V, input pulse levels of 0 to 2.5V, and output loading of the specified I<sub>OL</sub>/I<sub>OH</sub> and load capacitance. Shown in (a), (b) and (c) of AC test loads.
- t<sub>CHZ</sub>, t<sub>CLZ</sub>, t<sub>EOV</sub>, t<sub>EOLZ</sub>, and t<sub>EOHZ</sub> are specified with a load capacitance of 5 pF as in part (b) of AC Test Loads. Transition is measured ±200 mV from steady-state voltage.
- At any given voltage and temperature, t<sub>EOHZ</sub> is less than t<sub>EOLZ</sub> and t<sub>CHZ</sub> is less than t<sub>CLZ</sub>.

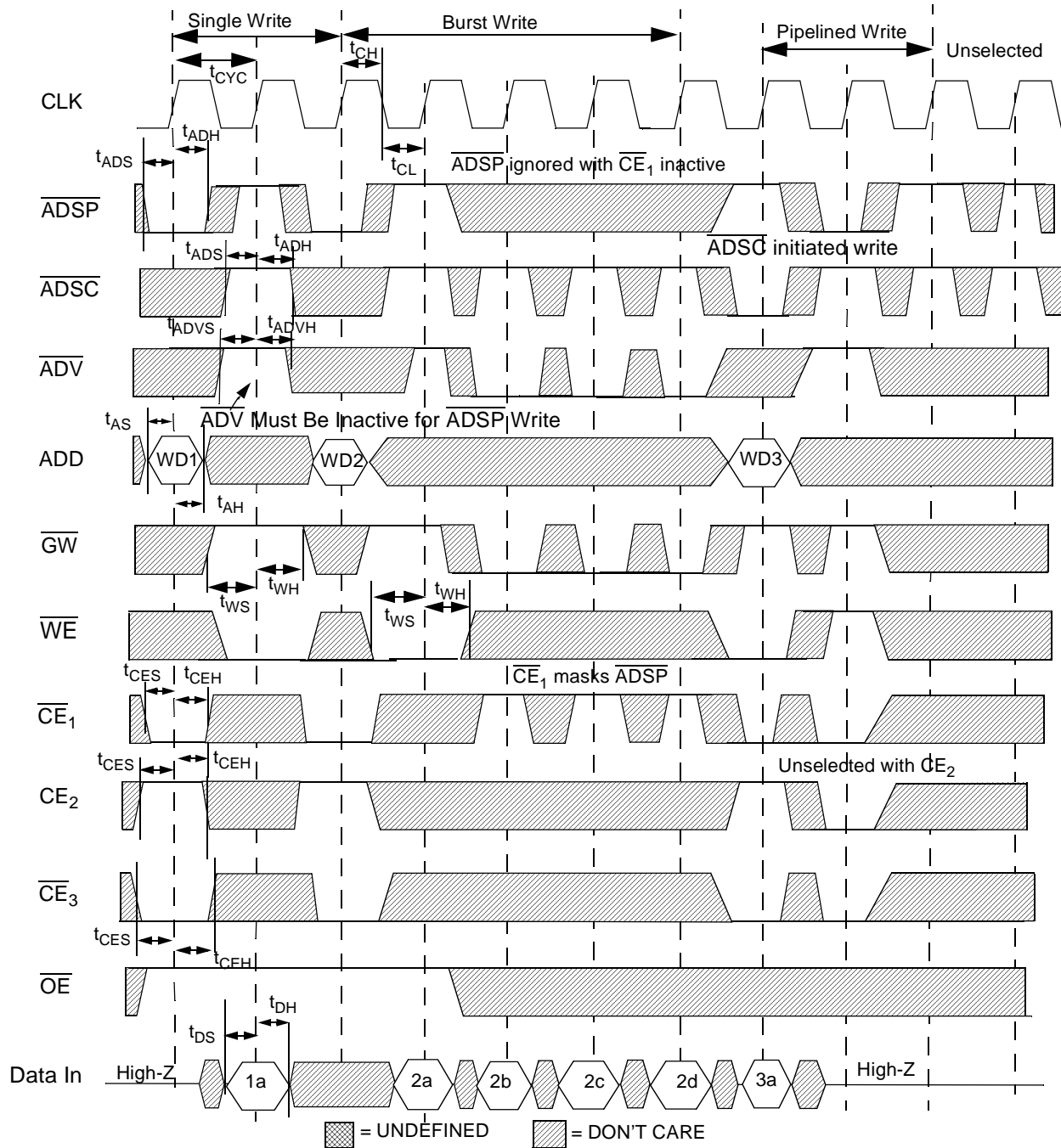
**Switching Waveforms**
**Write Cycle Timing<sup>[15, 16]</sup>**

**Notes:**

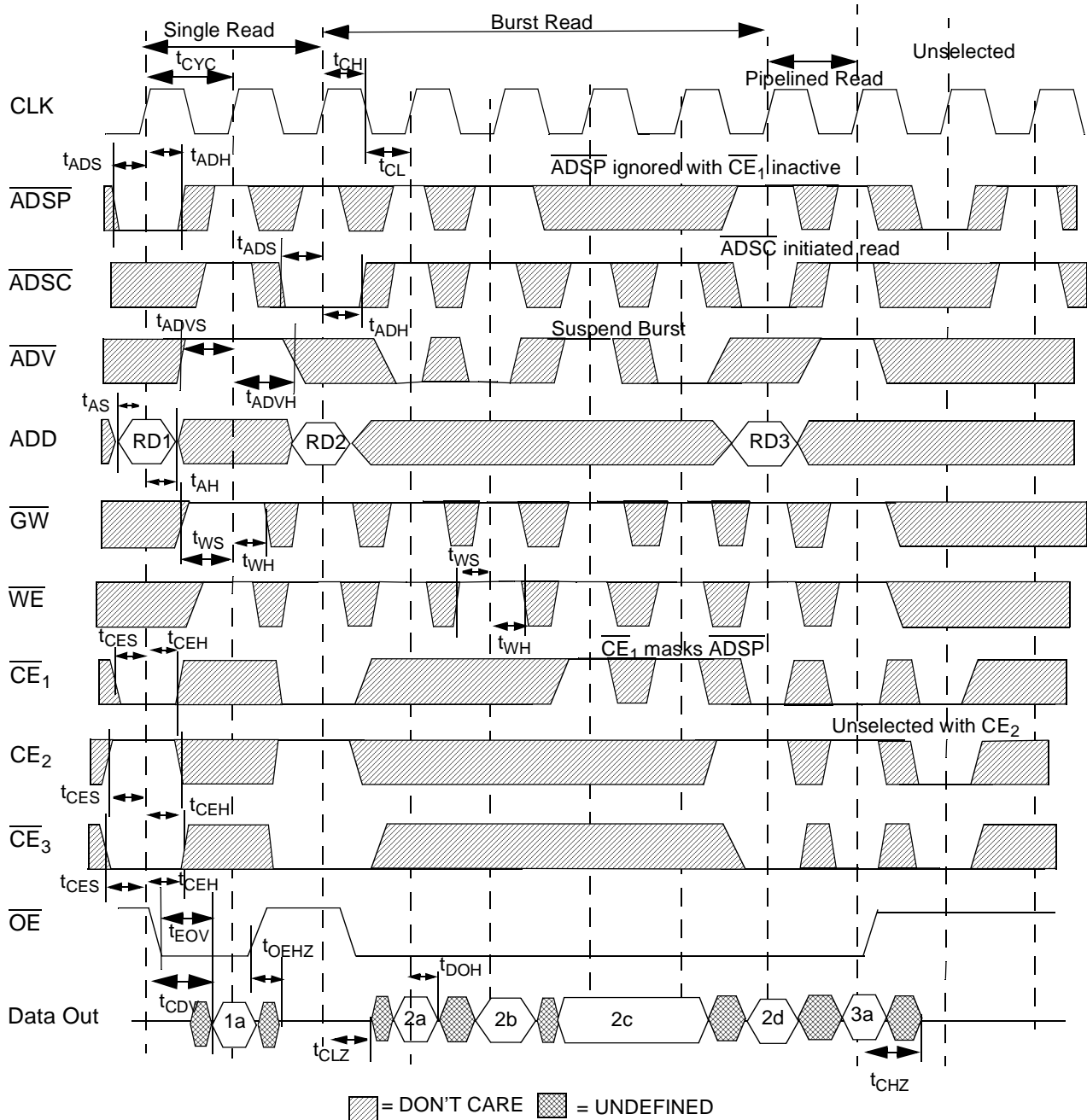
15.  $\overline{WE}$  is the combination of  $\overline{BWE}$ ,  $\overline{BWx}$ , and  $\overline{GW}$  to define a write cycle (see Write Cycle Descriptions table).
16.  $WDx$  stands for Write Data to Address X.

**Switching Waveforms (continued)**
**Read Cycle Timing<sup>[15, 17]</sup>**

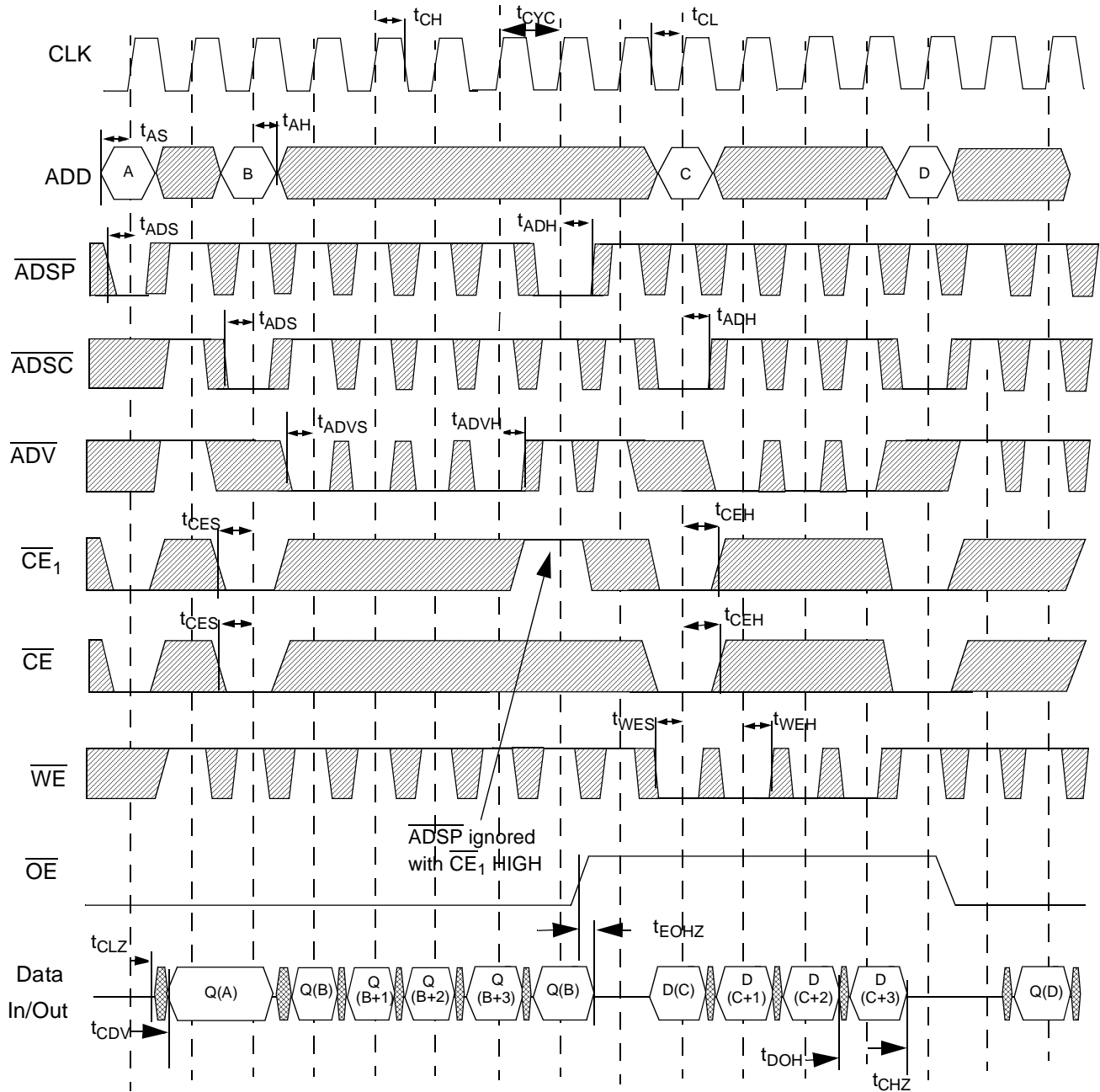
**Note:**

17. RDx stands for Read Data from Address X.

**Switching Waveforms (continued)**
**Read/Write Cycle Timing<sup>[15, 16, 17]</sup>**
**Read/Write Timing**

Device originally deselected

$\overline{WE}$  is the combination of  $\overline{BWE}$ ,  $\overline{BW}_x$ , and  $\overline{GW}$  to define a write cycle (see Write Cycle Description table).  $\overline{CE}$  is the combination of  $\overline{CE}_2$  and  $\overline{CE}_3$ . All chip selects need to be active in order to select the device. RAx stands for Read Address X, WAx stands for Write Address X, Dx stands for Data-in X, Qx stands for Data-out X.

▨ = DON'T CARE    ▩ = UNDEFINED

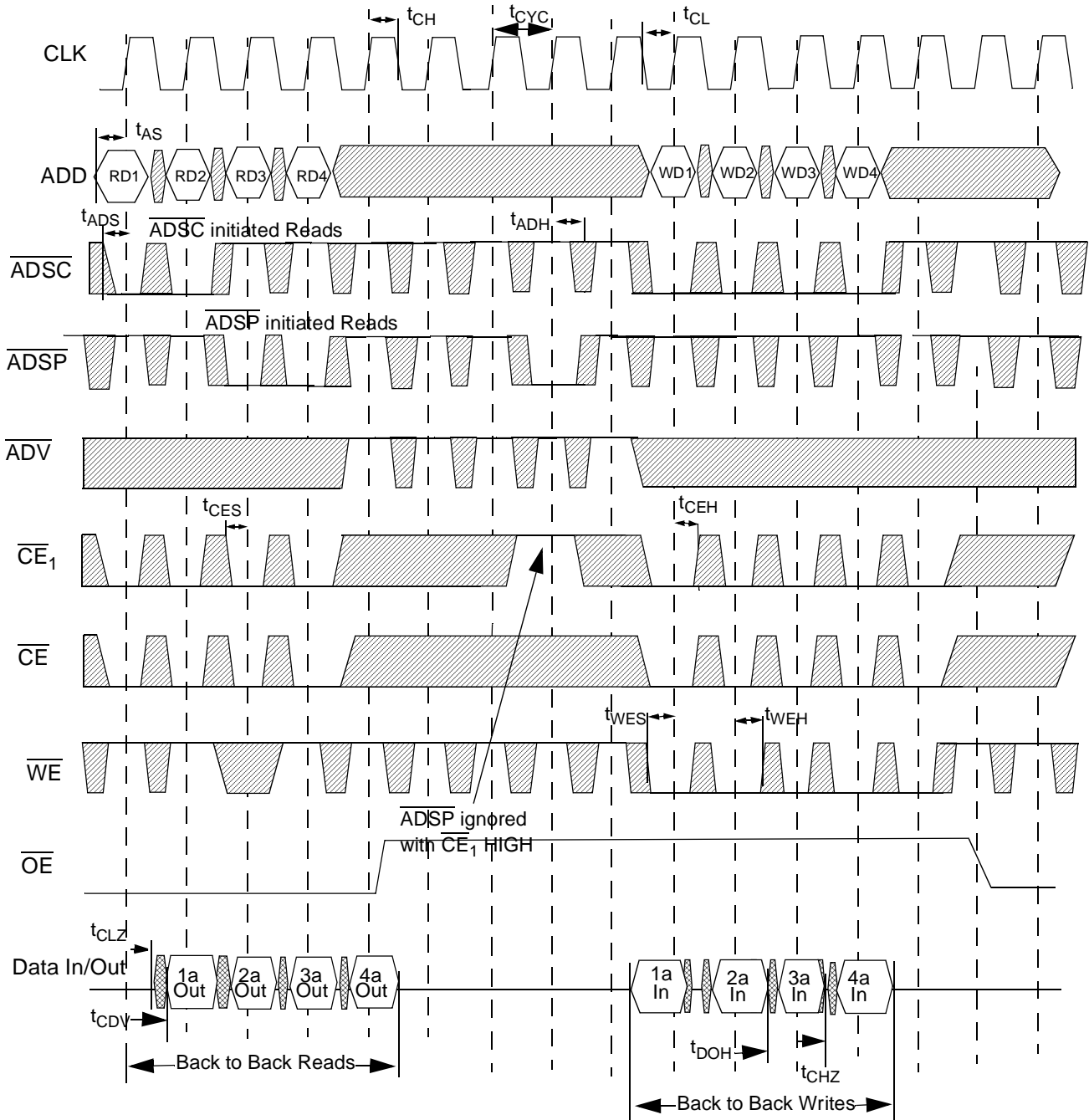

**Switching Waveforms (continued)**
**Pipeline Timing<sup>[18, 19]</sup>**

▨ = DON'T CARE    ▩ = UNDEFINED

**Notes:**

- 18.  $\overline{DE}$  device originally deselected.
- 19.  $\overline{CE}$  is the combination of  $\overline{CE}_2$  and  $\overline{CE}_3$ . All chip selects need to be active in order to select the device.

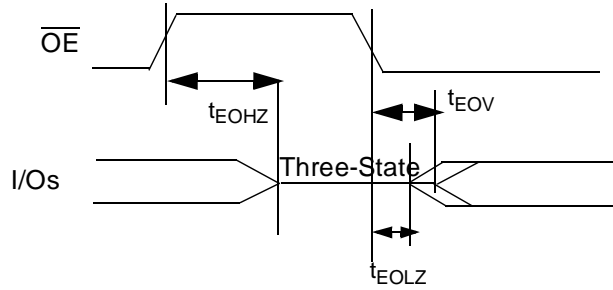
**Switching Waveforms** (continued)**OE Switching Waveforms**

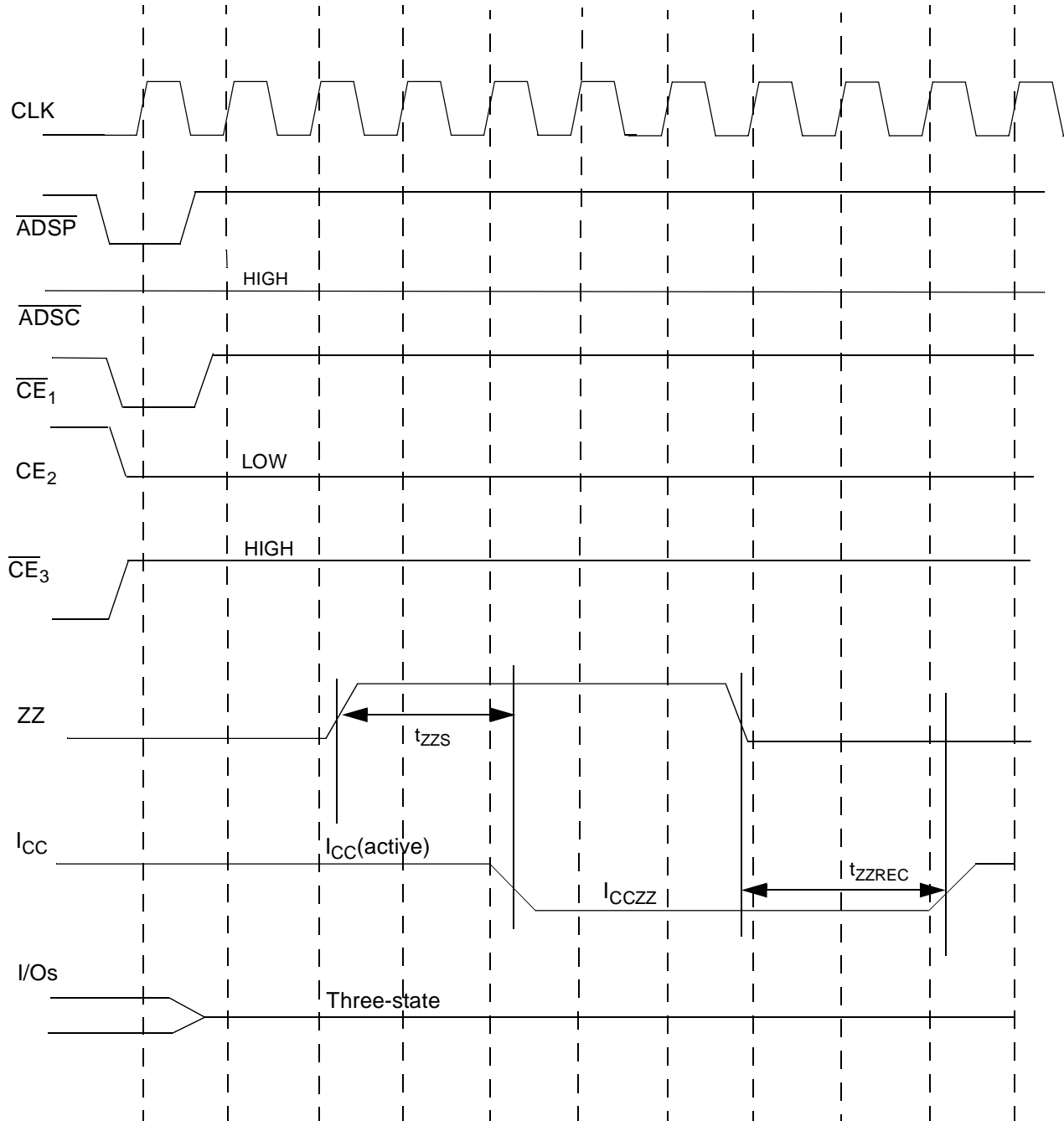
**Switching Waveforms (continued)**
**ZZ Mode Timing** <sup>[18, 20]</sup>

**Note:**

20. I/Os are in three-state when exiting ZZ sleep mode.



**PRELIMINARY**

**CY7C1381BV25**  
**CY7C1383BV25**

**Ordering Information**

Speed (MHz)	Ordering Code	Package Name	Package Type	Operating Range
133	CY7C1381BV25-133AC	A101	100-Lead Thin Quad Flat Pack	Commercial
117	CY7C1381BV25-117AC			
100	CY7C1381BV25-100AC			
133	CY7C1383AV25-133AC			
117	CY7C1383AV25-117AC			
100	CY7C1383AV25-100AC			
133	CY7C1381BV25-133BGC	BG119	119 Ball BGA	
117	CY7C1381BV25-117BGC			
100	CY7C1381BV25-100BGC			
133	CY7C1381BV25-133BGC			
117	CY7C1381BV25-117BGC			
100	CY7C1381BV25-100BGC			

Document #:38-01075-\*\*



**Package Diagrams (continued)**
**119-Lead FBGA (14 x 22 x 2.4 mm) BG119**

DIMENSION IN MILLIMETERS (INCHES)

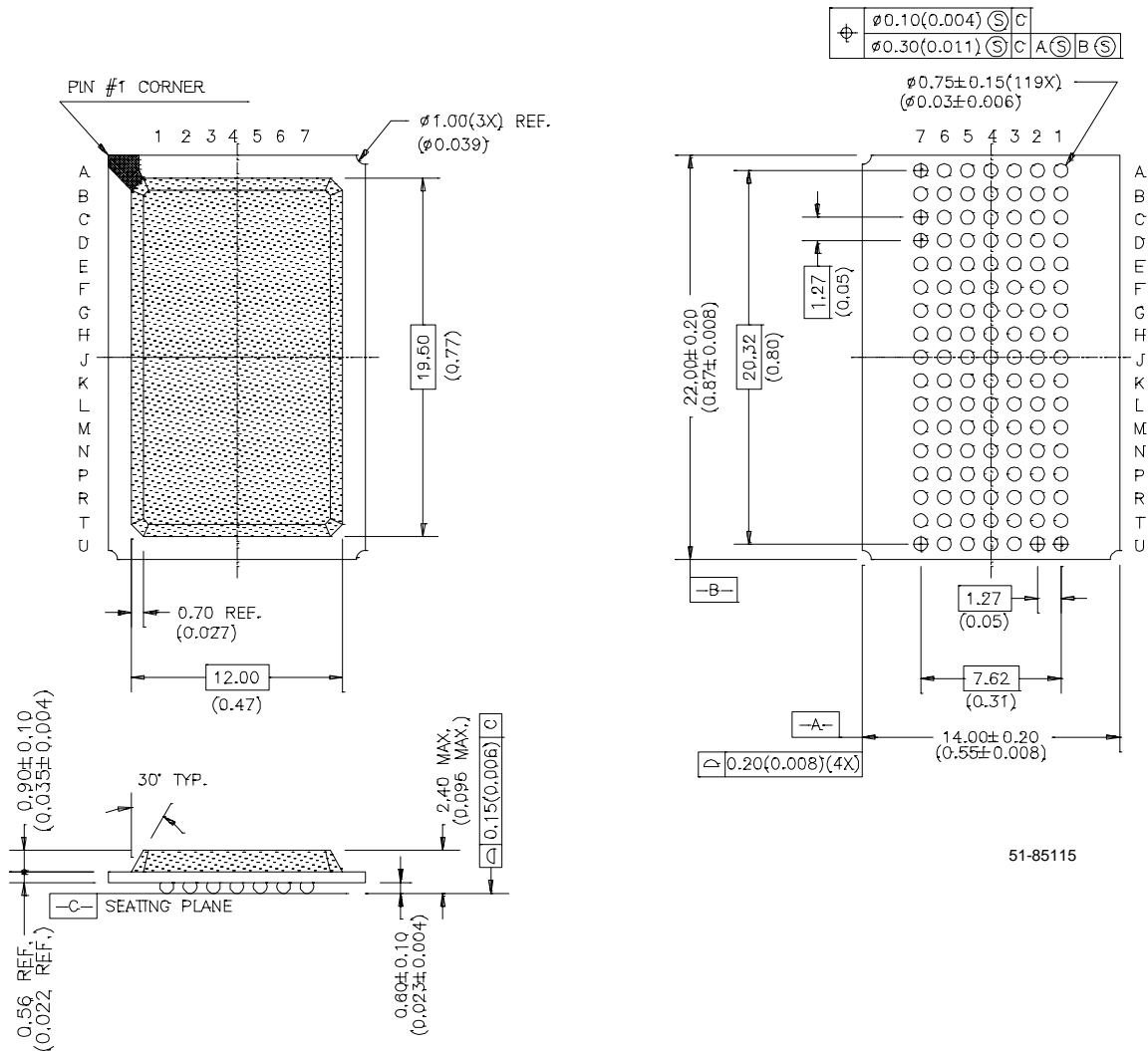

51-85115

**Revision History**
**Document Title: CY7C1381BV25/CY7C1383BV25**  
**Document Number: 38-01076**

REV.	ECN NO.	ISSUE DATE	ORIG. OF CHANGE	DESCRIPTION OF CHANGE
**	3350	9/29/2000	21. SKX	1. New Datasheet