



MBR25HxxCT, MBRF25HxxCT & MBRB25HxxCT Series

New Product

Vishay Semiconductors
formerly General Semiconductor

Dual High-Voltage Schottky Rectifiers

Reverse Voltage 90 to 100 V
Forward Current 20 A

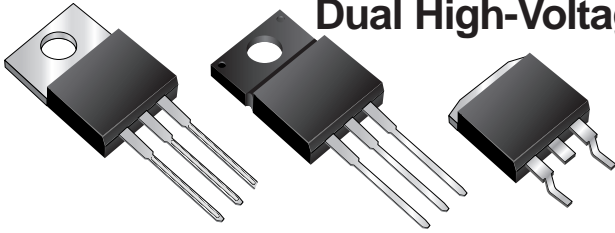

TO-220AB (MBR25HxxCT)

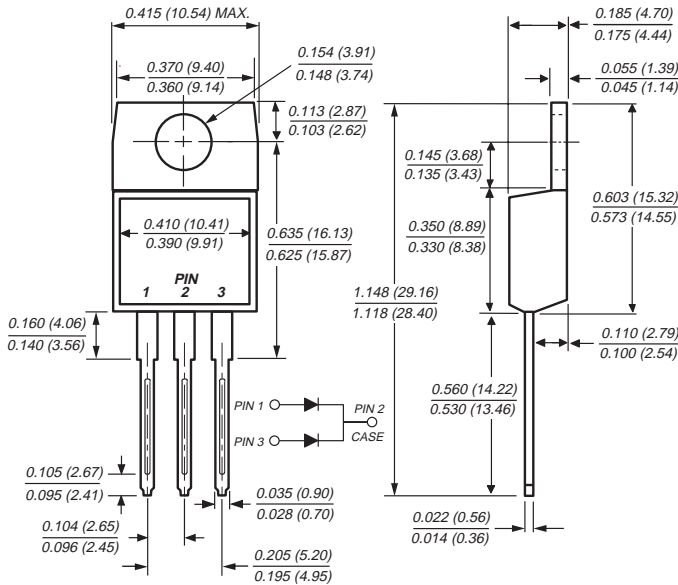

ITO-220AB (MBRF25HxxCT)

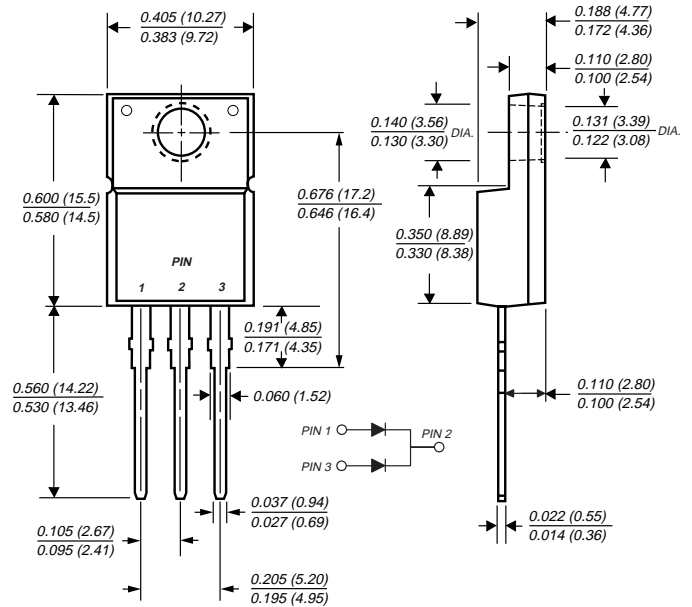

Mounting Pad Layout TO-263AB

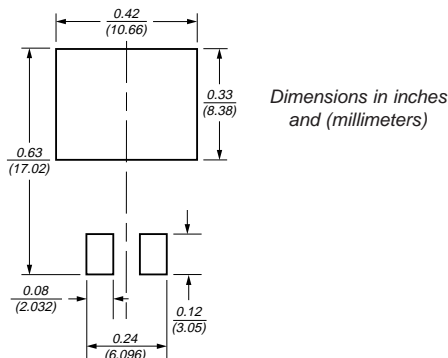

TO-263AB (MBRB25HxxCT)

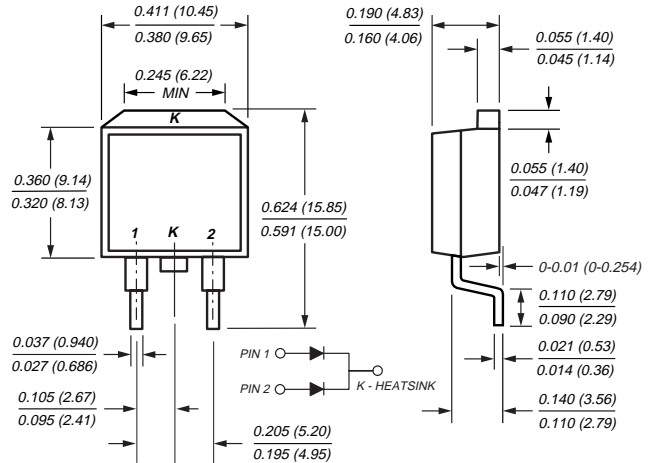

Mechanical Data

Case: JEDEC TO-220AB, ITO-220AB & TO-263AB molded plastic body

Terminals: Plated leads, solderable per MIL-STD-750, Method 2026

High temperature soldering guaranteed: 250 °C/10 seconds, 0.25" (6.35 mm) from case

Polarity: As marked **Mounting Position:** Any

Mounting Torque: 10 in-lbs maximum

Weight: 0.08 oz., 2.24 g

Features

- Plastic package has Underwriters Laboratory Flammability Classification 94 V-0
- Dual rectifier construction, positive center tap
- Metal silicon junction, majority carrier conduction
- Low forward voltage drop, low power loss and high efficiency
- Guardring for overvoltage protection
- For use in low voltage, high frequency inverters, free wheeling, and polarity protection applications
- Rated for reverse surge and ESD
- 175 °C maximum operation junction temperature

MBR25HxxCT, MBRF25HxxCT & MBRB25HxxCT Series



Vishay Semiconductors

formerly General Semiconductor

Maximum Ratings (T_C = 25°C unless otherwise noted)

Parameter	Symbol	MBR25H35CT	MBR25H45CT	MBR25H50CT	MBR25H60CT	Unit
Maximum repetitive peak reverse voltage	V _{RRM}	35	45	50	60	V
Working peak reverse voltage	V _{RWM}	35	45	50	60	V
Maximum DC blocking voltage	V _{DC}	35	45	50	60	V
Max. average forward rectified current (see fig. 1) <i>Total device Per leg</i>	I _{F(AV)}	30 15				A
Peak repetitive forward current at T _C = 150°C (rated V _R , 20KHz sq. wave)	I _{FRM}	30				A
Non-repetitive avalanche energy per leg at 25°C, I _{AS} = 4A, L = 10mH	E _{AS}	80				mJ
Peak forward surge current 8.3ms single half sine-wave superimposed on rated load (JEDEC Method) per leg	I _{FSM}	150				A
Peak repetitive reverse surge current per leg at t _p = 2.0μs, 1KHz	I _{RRM}	1.0		0.5		A
Peak non-repetitive reverse energy (8/20μs waveform)	E _{RSM}	25		20		mJ
Electrostatic discharge capacitor voltage Human body model: C = 100pF, R = 1.5kΩ	V _C	25				kV
Voltage rate of change (rated V _R)	dv/dt	10,000				V/μs
Operating junction temperature range	T _J	-65 to +175				°C
Storage temperature range	T _{STG}	-65 to +175				°C
RMS Isolation voltage (MBRF type only) from terminals to heatsink with t = 1.0 second, RH ≤ 30%	V _{ISOL}	4500 ⁽¹⁾ 3500 ⁽²⁾ 1500 ⁽³⁾				V

Electrical Characteristics (T_C = 25°C unless otherwise noted)

Parameter	Symbol	MBR25H35CT, MBR25H45CT, MBR25H50CT, MBR25H60CT				Unit
		Typ	Max	Typ	Max	
Maximum instantaneous forward voltage per leg ⁽⁴⁾ at I _F = 15A T _J = 25°C at I _F = 15A T _J = 125°C at I _F = 30A T _J = 25°C at I _F = 30A T _J = 125°C	V _F	– 0.50 – 0.63	0.64 0.54 0.74 0.67	– 0.56 – 0.68	0.70 0.60 0.85 0.72	V
Maximum instantaneous reverse current at rated DC blocking voltage per leg ⁽⁴⁾	I _R	– 6.0	100 20	– 4.0	100 20	μA mA

Thermal Characteristics (T_C = 25°C unless otherwise noted)

Parameter	Symbol	MBR	MBRF	MBRB	Unit
Thermal resistance from junction to case per leg	R _{θJC}	1.5	4.5	1.5	°C/W

Notes:

(1) Clip mounting (on case), where lead does not overlap heatsink with 0.110" offset
(2) Clip mounting (on case), where leads do overlap heatsink

(3) Screw mounting with 4-40 screw, where washer diameter is ≤ 4.9 mm (0.19")
(4) Pulse test: 300μs pulse width, 1% duty cycle

Ordering Information

Product	Case	Package Code	Package Option
MBR25H35CT – MBR25H60CT	TO-220AB	45	Anti-Static tube, 50/tube, 2K/carton
MBRF25H35CT – MBRF25H60CT	ITO-220AB	45	Anti-Static tube, 50/tube, 2K/carton
MBRB25H35CT – MBRB25H60CT	TO-263AB	31	13" reel, 800/reel, 4.8K/carton
		45	Anti-Static tube, 50/tube, 2K/carton
		81	Anti-Static 13" reel, 800/reel, 4.8K/carton



Ratings and Characteristic Curves ($T_A = 25^\circ\text{C}$ unless otherwise noted)

Fig. 1 – Forward Current Derating Curve

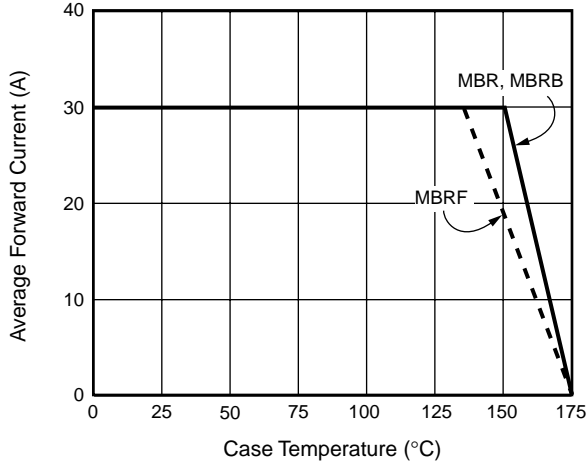

Fig. 2 – Maximum Non-Repetitive Peak Forward Surge Current Per Leg

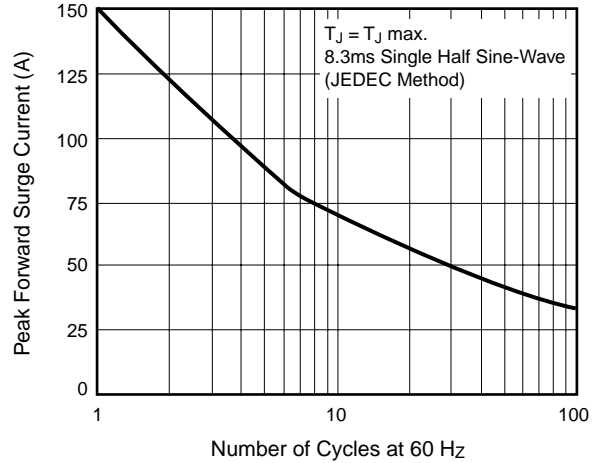

Fig. 3 – Typical Instantaneous Forward Characteristics Per Leg

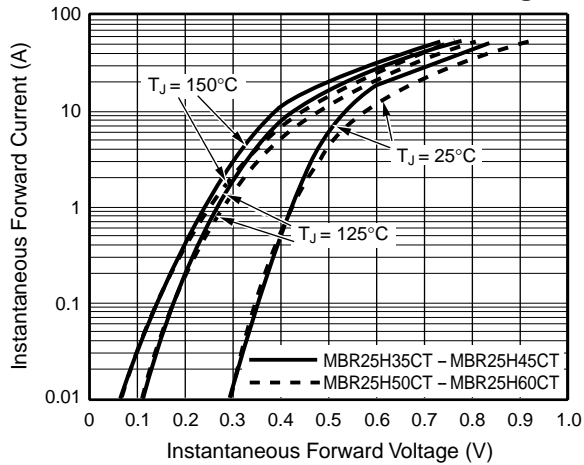

Fig. 4 – Typical Reverse Characteristics Per Leg

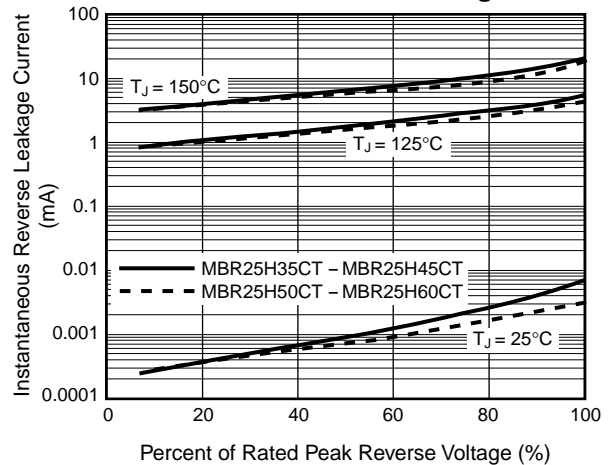

Fig. 5 – Typical Junction Capacitance Per Leg

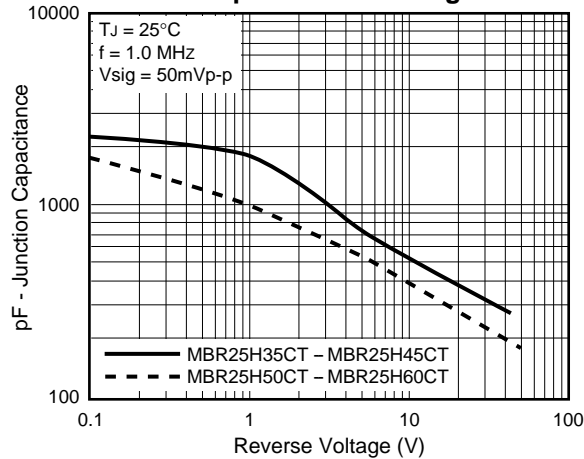

Fig. 6 – Typical Transient Thermal Impedance Per Leg

