

CSRV065V0P

RoHs Device

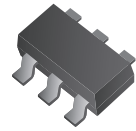

Features

- ESD Protect for 4 high-speed I/O channels.
- IEC61000-4-2 (ESD) $\pm 14\text{kV}$ (Contact), $\pm 18\text{kV}$ (Air).
- IEC61000-4-4 (FET)20A for I/O,80A for Power.
- Working voltage: 5V
- Low capacitance:1.3pF(Typ.).
- High component density.

Mechanical data

- Case: SC70-6L(SOT-363) standard package, molded plastic.
- Terminals: Solder plated, solderable per MIL-STD-750,method 2026.
- Mounting position: Any
- Weight: 0.0091 gram(approx.).

Circuit Diagram

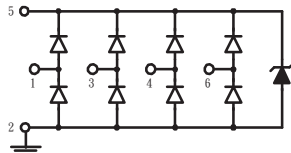

Pin Configuration

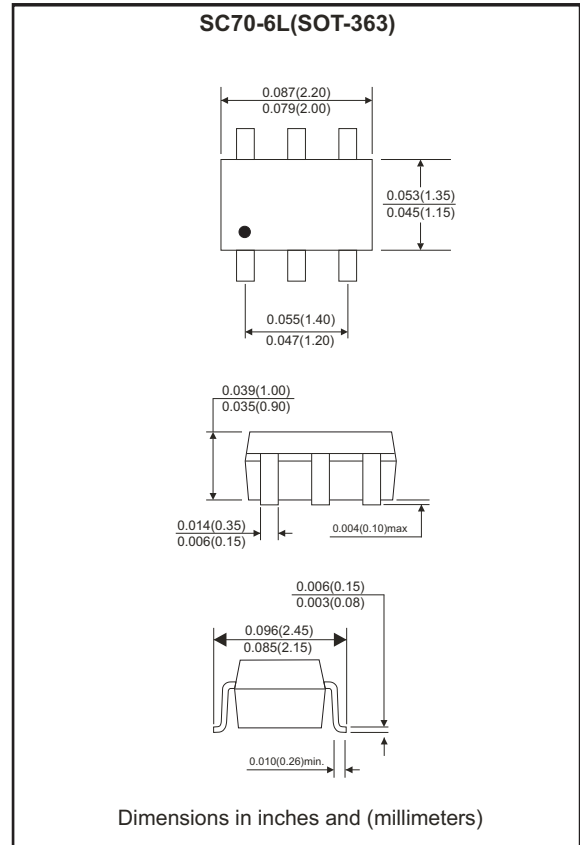
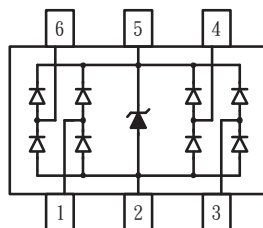

Maximum Ratings (at TA=25°C unless otherwise noted)

| Parameter | Symbol | Value | Unit |
|--------------------------------------------------------------------------------|--------------------|--------------------------|------|
| Peak pulse current (tp = 8/20 us) | I _{PP} | 6.5 | A |
| Operating supply voltage | V _{DC} | 6 | V |
| ESD per IEC 61000-4-2(Air) ESD per IEC 61000-4-2(Contact) | ESD | 18 14 | kV |
| ESD per IEC 61000-4-2(Air)(VDD-GND) ESD per IEC 61000-4-2(Contact)(VDD-GND) | ESD _{VDD} | 30 | kV |
| Lead soldering temperature | T _{SOL} | 260 (10 sec) | °C |
| Operating temperature | T _J | -55 to +85 | °C |
| Storage temperature | T _{STG} | -55 to +125 | °C |
| DC voltage at any I/O pin | V _{IO} | (GND -0.5) to (VDD +0.5) | V |

Electrical Characteristics (at TA=25°C unless otherwise noted)

| Parameter | Conditions | Symbol | Min | Typ | Max | Unit |
|---------------------------|----------------------------------------------------------------------------------------------------------------------------|-----------|-----|------|------|------|
| Reverse stand-Off voltage | Pin 5 to Pin 2 | V_{RWM} | | | 5 | V |
| Reverse leakage current | $V_{RWM} = 5V$, Pin 5 to Pin 2 | I_R | | | 5 | uA |
| | $V_{PIN5} = 5V$, $V_{PIN2} = 0V$, $V_{IO} = 0\sim 5V$ | | | | 1 | |
| Diode breakdown voltage | $I_R = 1mA$, Pin 5 to Pin 2 | V_{BD} | 6 | | 9 | V |
| Forward voltage | $I_F = 15mA$, Pin 2 to Pin 5 | V_F | | 0.8 | 1 | V |
| Clamping voltage | $I_{PP} = 5A$, $t_p = 8/20\mu s$, Any Channel Pin to Ground | V_C | | 8.1 | 9 | V |
| | IEC 61000-4-2 +6kV, Contact mode Any Channel Pin to Ground | | | 12.5 | | |
| | IEC 61000-4-2 +6kV, Contact mode VDD Pin to Ground | | | 9 | | |
| Junction capacitance | $V_{pin5} = 5V$, $V_{pin2} = 0V$, $V_{IO} = 2.5V$, $f = 1MHz$, Any Channel Pin to Ground | C_j | | 1.3 | 1.6 | pF |
| | $V_{pin5} = 5V$, $V_{pin2} = 0V$, $V_{IO} = 2.5V$, $f = 1MHz$, Between Channel Pins | | | 0.12 | 0.14 | |
| | $V_{pin5} = 5V$, $V_{pin2} = 0V$, $V_{IN} = 2.5V$, $f = 1MHz$, Channel_x pin to ground - channel_y pin to ground | | | 0.05 | 0.07 | |

RATING AND CHARACTERISTIC CURVES (CSRV065V0P)

Fig. 1 - Power derating curve

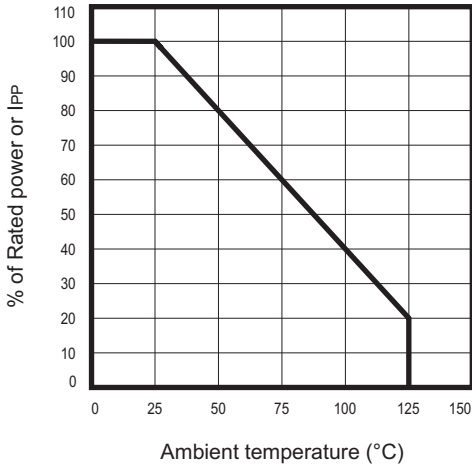

Fig. 2 - Clamping voltage vs. Peak pulse current

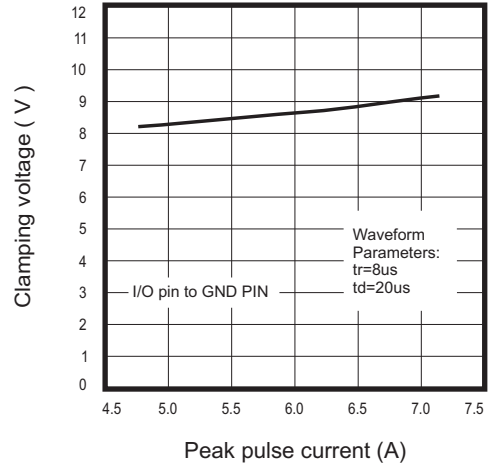

Fig.3 - Forward voltage v.s. forward current

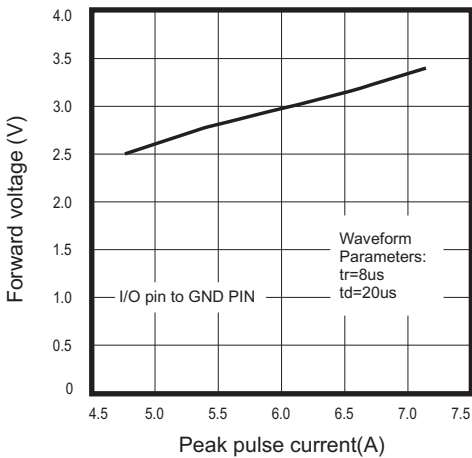

Fig.4 - Typical variation of C_{IN} v.s. V_{IN}

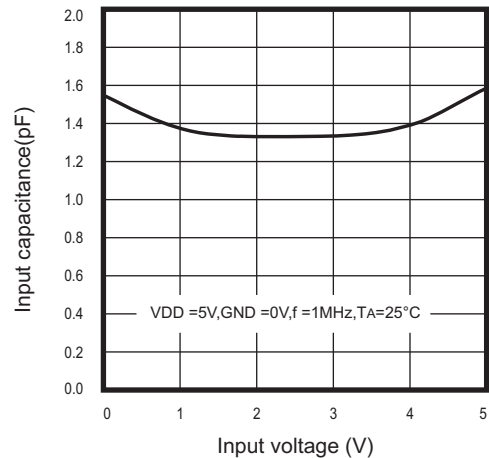

Fig. 5 - Typical variation of C_{IN} v.s. temperature

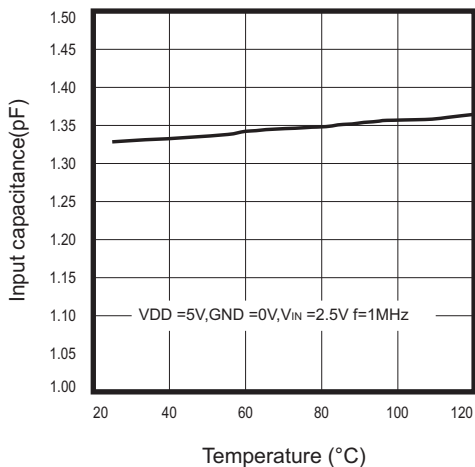

Fig. 6 - Transmission line pulsing (TLP) measurement

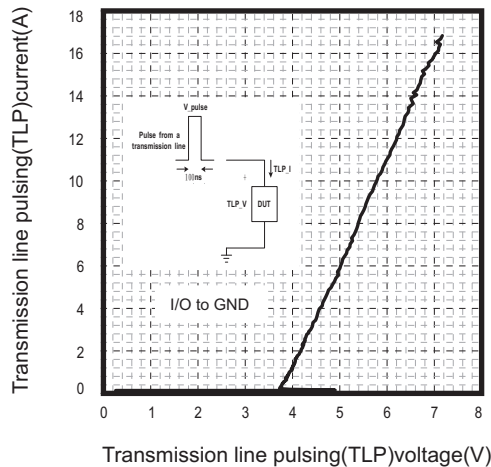
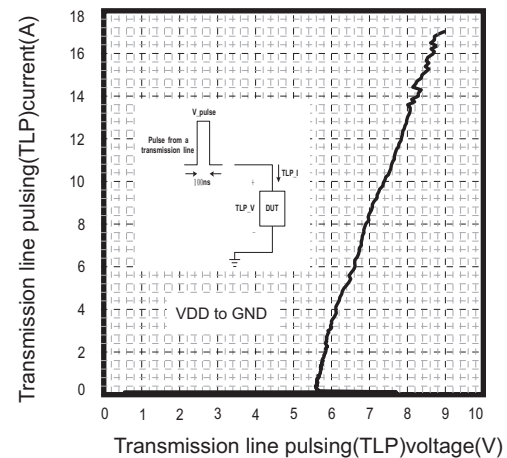
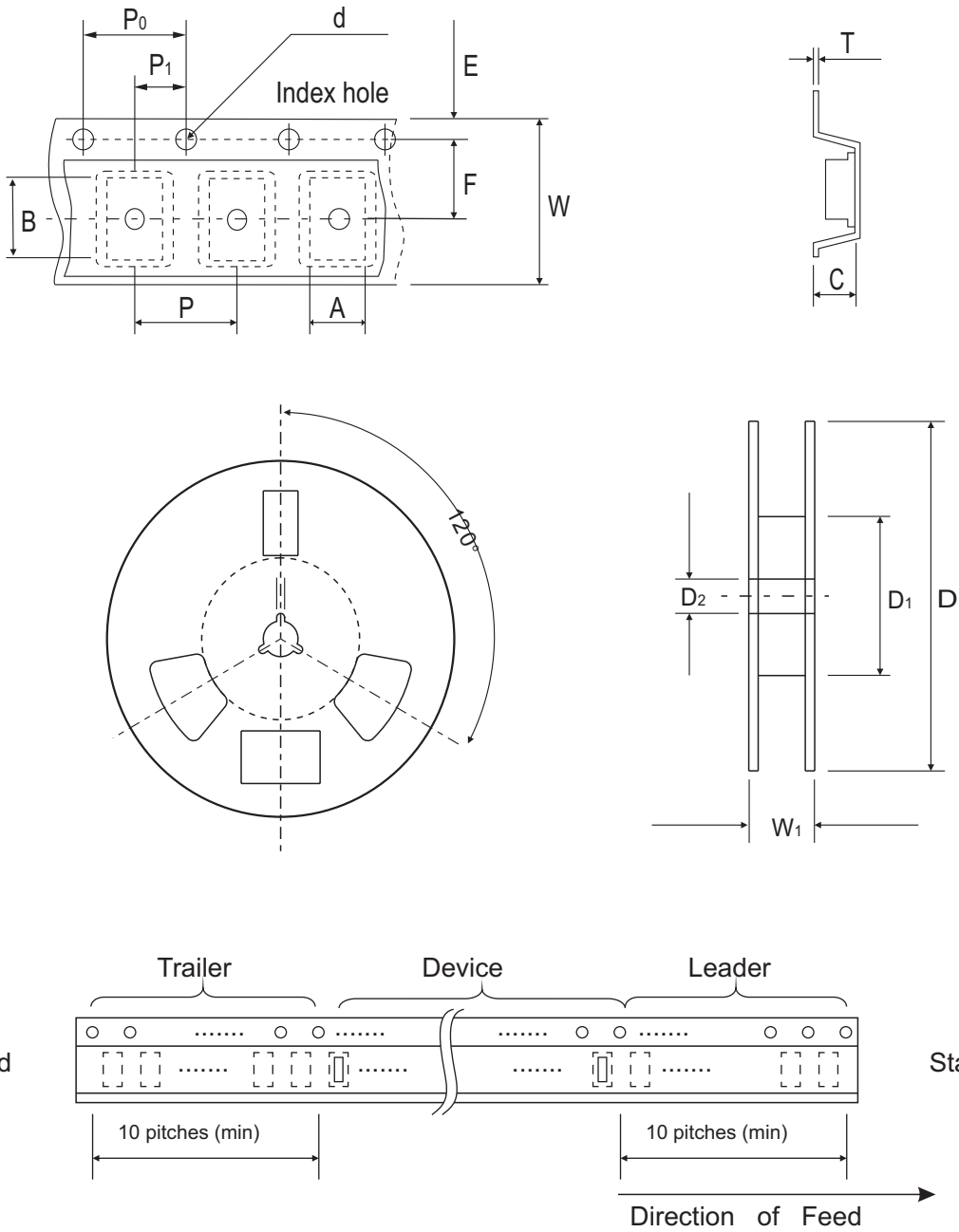

Fig.7 -Transmission line pulsing (TLP) measurement



Reel Taping Specification



| | | | | | | | | |
|----------------------|--------|---------------|---------------|---------------|---------------|---------------|------------|---------------|
| SC70-6L (SOT-363) | SYMBOL | A | B | C | d | D | D1 | D2 |
| | (mm) | 2.20 ± 0.10 | 2.40 ± 0.10 | 1.35 ± 0.10 | 1.55 ± 0.10 | 178 ± 1 | 50.0 MIN. | 13.0 ± 0.20 |
| | (inch) | 0.087 ± 0.004 | 0.094 ± 0.004 | 0.053 ± 0.004 | 0.061 ± 0.004 | 7.008 ± 0.040 | 1.969 MIN. | 0.512 ± 0.008 |

| | | | | | | | | |
|----------------------|--------|---------------|---------------|---------------|---------------|---------------|---------------|------------|
| SC70-6L (SOT-363) | SYMBOL | E | F | P | P0 | P1 | W | W1 |
| | (mm) | 1.75 ± 0.10 | 3.50 ± 0.05 | 4.00 ± 0.10 | 4.00 ± 0.10 | 2.00 ± 0.05 | 8.00 ± 0.30 | 14.4 MAX. |
| | (inch) | 0.069 ± 0.004 | 0.138 ± 0.002 | 0.157 ± 0.004 | 0.157 ± 0.004 | 0.079 ± 0.002 | 0.315 ± 0.012 | 0.567 MAX. |

Marking Code

| Part Number | Marking Code |
|-------------|--------------|
| CSRV065V0P | C05XY |

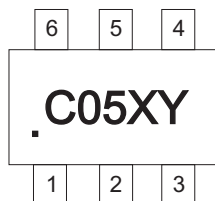

C05 = Device code
 X = Date Code
 Y = Control Code

Suggested PAD Layout

| SIZE | SC70-6L(SOT-363) | |
|------|------------------|--------|
| | (mm) | (inch) |
| A | 0.80 | 0.031 |
| B | 0.35 | 0.014 |
| C | 1.30 | 0.051 |
| D | 1.94 | 0.076 |
| E | 2.74 | 0.108 |

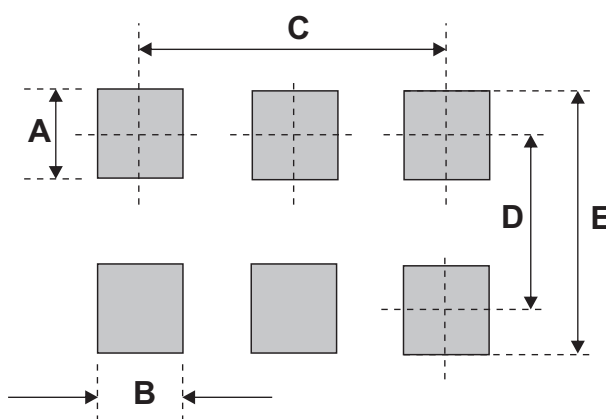

Standard Packaging

| Case Type | REEL PACK | |
|-------------------|--------------|------------------|
| | REEL (pcs) | Reel Size (inch) |
| SC70-6L (SOT-363) | 3,000 | 7 |